



## **STANDARDS FOR DESIGN AND CONSTRUCTION**

City of Great Falls, Montana

Specifications Filed in the Office of the City Engineer

**On May 19, 2020**

**ADOPTED: May 19, 2020 - Resolution 10346**

**REVISION NUMBER 1 - JUNE 8, 2020**

**REVISION NUMBER 2 - OCTOBER 13, 2021**

**REVISION NUMBER 3 – NOVEMBER 1, 2023**



## Table of Contents

FOREWORD .....	4
Glossary of Acronyms and Terms .....	5
Chapter 1 Construction within City Right-of-Way .....	10
Chapter 2 Design Criteria .....	25
Chapter 3 Project Submittals .....	31
Chapter 4 Development.....	36
Chapter 5 Water System .....	40
Chapter 6 Sanitary Sewer System .....	56
Chapter 7 Storm Sewer Systems.....	78
Chapter 8 Transportation System.....	80
Appendix A – Example Ownership Transfer Letter.....	90
Appendix B - Application for Driveway Construction .....	92
Appendix C – Checklist & Deviation Request.....	96
Appendix D – Low Pressure Grinder Pump Systems.....	102
Appendix E – Additional Infrastructure Review Fee Guidance and Examples.....	110
Appendix F – Preconstruction Meeting Documents.....	118
City of Great Falls Standard Details .....	126

## FOREWORD

*This guide has been prepared to assist design engineers, architects, developers, contractors, or other interested individuals with the preparation of plans and specifications for public infrastructure improvements. The purpose of this information is to provide guidance regarding minimum standards for design, materials, and methods of construction; where any portion of such improvement is to be offered to the City for operation and maintenance. Every project is unique and as such, the information presented in this guide does not apply in all situations.*

*This guide is intended to be used in conjunction with the Montana Public Works Standard Specifications and the Official Code of the City of Great Falls. If any portion of this document is found to conflict with the Official Code of the City of Great Falls (OCCGF) the provisions of the OCCGF shall supersede this document.*

*Please note that the information in this guide will be revised on an as-needed basis as regulations and policies are modified. This information is subject to change over time and all changes shall be approved by the City of Great Falls Public Works Director and the City Manager. Please reference the latest rendition located on the City's web page at the time of construction.*

*Not all design criteria and drawings are applicable in all situations. It is not the intent of the City of Great Falls to unreasonably limit any innovative or creative effort that could result in a superior design based on the performance criteria of safety, economical maintenance, and pleasant appearance. Proposed departures from these standards by the Design Team will be evaluated by PW Engineering Staff on the basis that the proposal will produce acceptable results for the user, the environment, and the public.*

## Glossary of Acronyms and Terms

<b>Term</b>	<b>Definition</b>
AASHTO	American Association of State Highway and Transportation Officials
ACI	American Concrete Institute
ADA	Americans with Disabilities Act
ADT	Average Daily Traffic
APWA	American Public Works Association
ANSI	American National Standards Institute
ARC	Antecedent Runoff Condition
ASA	American Standards Association
ASSE	American Society of Sanitary Engineering
ASTM	American Society for Testing and Materials
AWWA	American Water Works Association
BMP	Best Management Practice
CC&R	Conditions, Covenants, and Restrictions
cfs	Cubic Feet per Second
CI	Cast Iron
CMP	Corrugated Metal Pipe
CN	Curve Number
CoGF	City of Great Falls
Design Engineer	The Engineer that stamps the plans
DEQ	Department of Environmental Quality
DIP	Ductile Iron Pipe
DWG	AutoCAD Drawing File
ESAL	Equivalent Single Axle Load
ESC	Erosion and Sediment Control
FEMA	Federal Emergency Management Agency
FHWA	Federal Highway Administration
FIRM	Flood Insurance Rate Map
FL	Flange Joint
fps	Feet per Second
FS	Factor of Safety
GW	Grate Width
GSC	Geotechnical Site Characterization
HDPE	High Density Polyethylene
HDPP	High Density Polypropylene
HGL	Hydraulic Grade Line
HOA	Homeowner's Association
IBC	International Building Code
IDF	Intensity Duration Frequency
ITE	Institute of Transportation Engineers
kW	Kilowatt
LED	Light Emitting Diode
LLDPE	Linear Low Density Polyethylene
LOS	Level of Service

MDEQ	Montana Department of Environmental Quality
MDT	Montana Department of Transportation
MFE	Municipal Facilities Exclusion
MJ	Mechanical Joint
mg/l	Milligrams per Liter
MPWSS	Montana Public Works Standard Specifications
MUTCD	Manual on Uniform Traffic Control Devices
NAVD 88	North American Vertical Datum 1988
NBR	Acrylonitrile-Butadiene Copolymer
NDW	Natural Drainage Way
NOAA	National Oceanic and Atmospheric Administration
NPDES	National Pollution Discharge Elimination System
NPT	National Pipe Thread Tapered
NRCS	Natural Resources Conservation Service
NWE	Northwestern Energy
O&M	Operation and Maintenance
OCCGF	Official Code of the City of Great Falls
OSHA	Occupation Safety and Health Administration
OSB	Oriented Strand Board
PC	Point of Curvature
PCC	Point of Compound Curvature
PCD	City of Great Falls Planning and Community Development Department
PLSS	Public Land Survey System
PO	Push-On Joint
POA	Property Owner's Association
Pollutant Generating Surface	Any surface where pollutants can be generated including, but not limited to roofs, landscaped areas, driving surfaces, and parking areas.
Professional Engineer	Montana Licensed Professional Engineer (AKA PE, MT PE, or Engineer)
Project Engineer	Developer's Consulting Engineer that is working on the project
psig	Pounds Per Square Inch Gauge
PT	Point of Tangency
PTOE	Professional Traffic Operations Engineer
PVC	Polyvinyl Chloride
PWD	City of Great Falls Public Works Department
RCP	Reinforced Concrete Pipe
Rebar	Reinforcing Bar
ROW	Right-of-Way
SBR	Styrene Butadiene Copolymer
SDR	Standard Dimension Ratio
SCS	Soil Conservation Service
sf	Square Foot
SOI	Sand, Oil Interceptors
Standards	Current City of Great Falls Standards for Design and Construction
Stormwater Facility	Any conveyance swale, ditch, pond, storage facility, structure, or BMP
TBC	Top Back of Curb

TIA	Traffic Impact Analysis
TPH	Total Petroleum Hydrocarbons
TSS	Total Suspended Solids
UPC	Universal Plumbing Code
USCS	Unified Soil Classification System
USGS	United States Geological Survey
VCP	Vitrified Clay Pipe
VPI	Vertical Point of Intersection





# CHAPTER 1 - CONSTRUCTION WITHIN CITY RIGHT-OF-WAY

## Chapter 1 Construction within City Right-of-Way

### 1.1. GENERAL PROVISIONS

#### 1.1.1 Standards

- A. The latest published edition of Division 1, Division 2, Division 3 and the Appendix of the Montana Public Works Standard Specifications (*MPWSS*) is adopted, except as amended herein. With respect to the design and/or construction of public facilities, and conflict(s) or difference(s) between the MPWSS, the Official City Code of Great Falls (OCCGF), and the CoGF Standards for Design and Construction (Standards) shall be resolved in favor of the OCCGF, these Standards, then the MPWSS;
- B. New construction will be built under the Standards in effect at the time of plan approval; and
- C. If construction of the approved plans is not completed within 3 years from the date of design approval, and updates to the Standards have occurred since the date of approval, the design plans, specifications, and reports shall be resubmitted for City review and approval. City review fees for additional reviews of previously approved plans may apply.

#### 1.1.2 Public Right-of-Way Permit

- A. Except when such person is operating under a contract with the CoGF, all construction, excavation, or other work on public or private property which will necessitate the use of the public right-of-way or easement shall require a public Right-of-Way Permit issued by the Planning and Community Development Department (PCD);
- B. The work authorized by the Permit includes, but is not limited to: dry utility installation, connections, and repair within the ROW; retaining wall construction and repair within the ROW; excavating in, cutting through, or tearing open any City street, avenue, alley, sidewalk, boulevard, or any other public way;
- C. Also included are any other uses of the public right-of-way where there is a possibility of creating a hazard. Examples of hazards are scaffolding, storage of materials or equipment, crane and equipment operations, demolition, sandblasting and painting operations, temporary construction or demolition dumpster placement and any other use deemed a hazard by the PWD;
- D. The Permit will not be issued until all insurance and bonding requirements have been met;
- E. The permittee shall accomplish the proposed work within the time allowed by the PWD Director and under the director's supervision (OCCGF Title 12);
- F. In an emergency which requires repairs to be made immediately, the Contractor may excavate and complete the repairs without first having obtained a Permit. Prior to beginning work at the site during normal working hours, the Contractor shall notify the PWD Engineering Division at 406-771-1258. During emergency repair and prior to beginning work after hours, the Contractor shall notify "One Call" that an emergency repair is needed. In either case, the Contractor shall describe the circumstances and provide the location of the emergency repairs. The Contractor shall obtain the Permit no later than the next scheduled City workday and call for the appropriate inspections;

- G. All provisions of the Standards shall be complied with regardless of the circumstances of the construction;
- H. The Contractor shall be responsible for damages to any/all infrastructure, including damages to the street, within the public right-of-way. The Street Division Manager shall determine the appropriate roadway fix. This may include, but is not limited to, a mill and overlay, chip seal, or sand seal;
- I. All excavation shall be thoroughly backfilled, and any such excavation or opening shall be restored to the condition it was prior to such excavation or opening, or better, except that the City will replace all asphaltic surfacing in paved streets, with costs to be paid by the applicant, unless the Public Works Director or designee authorizes the applicant to replace the asphaltic surfacing;
- J. Flowable fill shall be used to backfill trench excavation on arterial and collector streets and when deemed necessary by the Street Division Supervisor or designee on local streets and alleys;
- K. Flowable fill shall be used to cap street openings during the winter and whenever hot mix asphaltic surfacing is not available. The surfacing shall be maintained, by the permittee, until hot mix asphaltic surfacing becomes available; and
- L. Any settlement in a restored area which occurs within two (2) years of the date of completion of the permanent surfacing, shall be considered as conclusive evidence of defective backfill. Upon failure or refusal of such permittee to correct such settlement within five (5) days after notice by the Public Works Director or designee to do so, the City may correct such settlement and any expense incurred by the City in correcting such settlement shall be paid by the permittee (OCCGF 12.4.060.B).

#### 1.1.3 Sidewalk Permits and Curb Permits

- A. Except when such person is operating under a contract with the CoGF, all construction, excavation, and other work associated with sidewalks and curbs, including private service walk connections, within the public right-of-way or city easement shall require a Sidewalk Permit and/or a Curb and Gutter Permit issued by the Planning and Community Development Department (PCD);
- B. The Contractor is responsible for contacting the City Engineering Office (406-771-1258) and requesting inspections; and
- C. Refer to Chapter 8 “Transportation System” for sidewalk and curb design and construction standards.

#### 1.1.4 Driveway Permits

- A. Except when such person is operating under a contract with the CoGF, all construction, excavation, and other work associated with driveways and concrete crosswalks through driveways shall require a Curb Cut/Driveway permit issued by the PCD;
- B. A request for a new curb cut and for a curb cut wider than what is allowed in Title 17 shall be submitted in writing to the City Engineer and construction shall not start until the City Engineer has issued a determination;
- C. The Contractor is responsible for contacting the City Engineering Office (406-771-1258) and requesting inspections; and
- D. Refer to Chapter 8 “Transportation System” for driveway design and construction standards.

### 1.1.5 Infrastructure Review Fee

- A. Except when such person is operating under a contract with the Public Works Department, all privately installed infrastructure that will be dedicated to the City requires an Infrastructure Review Fee. At the time of infrastructure submittal application, the applicant shall submit an engineer's cost estimate prepared by a licensed professional engineer based on a schedule of values covering the comprehensive construction cost of the Public Works Infrastructure to be dedicated to the City. The Public Works Infrastructure shall include water, sanitary sewer, storm sewer, street, and alley improvements. The cost estimate will be utilized to calculate the Infrastructure Review Fee to cover Engineering Division plan review through approval and provide Engineering Division construction oversight. Due to construction cost escalation since 2020, the infrastructure cost in the fee equation below shall be fifty percent (50%) of the total engineer's cost estimate. The Engineering Division will continue to monitor the fee and make adjustments via future resolution as needed. The fee shall be calculated as follows:  
Fee =  $3.3182 * ((\text{Infrastructure Cost})^{0.6593})$
- B. The first half of the fee shall be due at the first submittal of the infrastructure plans and shall be accompanied with the engineer's cost estimate. The fee shall be paid by check to "City of Great Falls", credit card payments are not allowed. The first half of the fee shall be calculated by dividing the fee equation above by two using the infrastructure cost provided in the cost estimate. The City reserves the right to review and modify the cost estimate to be consistent with these requirements and recent bid tabulations. It is recommended that the applicant contact the Engineering Division, (406) 771-1258, to review the cost estimate prior to first submittal.
- C. The second half of the fee shall be due prior to scheduling the pre-construction meeting and shall be accompanied with the bid cost of the selected contractor based upon the schedule of values to complete the improvements. The second half of the Fee shall be calculated by the fee equation above where the infrastructure cost shall be fifty percent (50%) of the total bid cost, and then subtracting the first half amount paid at the plan submittal. The Engineering Division shall review the second half fee calculation, contractor's bid by schedule of values, and other necessary construction cost documents prior to submitting the second half of the fee. The engineer composing the cost estimate shall become familiar with the additional guidance and cost estimate examples in the Appendix E of these Standards.
- D. When a third party consultant is utilized to assist the City with plan review, no additional third party fees will be charged to the applicant and the City will pay the third party directly.
- E. The Infrastructure Review Fee does not include costs to provide inspection of Public Works Infrastructure via Engineering Division Inspectors or Third Party Consultants hired by the City, when allowed, as discussed in Chapter 3 of these Standards. Inspection by Engineering Division Inspectors shall be billed separately at hourly rates adopted by City resolution. Inspection by Third Party Consultants hired by the City, when allowed, shall be based upon hourly rates established by agreement between the City and the Third Party Consultant.
- F. The Infrastructure Review Fee does not include additional permitting costs or review fees necessary to construct the infrastructure including, but not limited to: Planning and

Community Development application fees, building permit fees or review fees, general plumbing permits, water service line permits, building sewer permits, right of way permits, sidewalk permits, driveway permits, curb cut permits, fire line permits, tapping fees, and other permits or fees as needed.

1.1.6 Private Stormwater Review Fee

- A. Except when such person is operating under a contract with the Public Works Department, all projects within City limits which meet the threshold to provide a Storm Drainage Plan or Stormwater Management Plan that require privately owned and maintained stormwater facilities, as outlined in the City's latest adopted Storm Drainage Design Manual and the Official Code of the City of Great Falls, shall submit a Private Stormwater Review Fee. The fee shall be added to the application fee or permit letting fee as applicable and collected by the Planning and Community Development Department in accordance with their procedures. As of October 5, 2023, the fee is \$797 per City Resolution 10519. The fee is not necessary when the storm water improvements will be dedicated to and maintained by the City and reviewed under the Infrastructure Review Fee.
- B. When a third party consultant is utilized to assist the City with plan review, no additional third party fees will be charged to the applicant and the City will pay the third party directly.
- C. This Private Stormwater Review Fee does not include additional permitting costs or review fees associated with stormwater management including, but not limited to: Erosion Control Plan (ECP), Storm Water Pollution Prevention Plan (SWPPP), Industrial Pretreatment Survey (IPS), building permit fees or review fees, parking lot permit fees or review fees, and other permit costs or review fee items required by the Environmental Division or Planning and Community Development Department.

1.1.7 Building Permit and Parking Lot Permit Review Fees

- A. Except when such person is operating under a contract with the Public Works Department, all projects within City limits which must obtain a building permit or parking lot permit shall submit a fee for Engineering Division review. As of October 5, 2023, the Commercial Building Permit, Single Family Residential Building Permit, and Parking Lot Permit fees are \$930, \$229, and \$399 respectively per City Resolution 10519. The fee shall be added to the application fee or permit letting fee as applicable and collected by the Planning and Community Development Department in accordance with their procedures.
- B. When a third party consultant is utilized to assist the City with plan review, no additional third party fees will be charged to the applicant and the City will pay the third party directly.
- C. The building permit and parking lot permit review fees are additive to the other Engineering Division and Planning and Community Development Department review fees including, but not limited to: the Infrastructure Review Fee, Private Stormwater Review Fee, building permit letting fee, application fee, and other permit fees or review fees as needed.

#### 1.1.8 City Fees

##### A. Water & Sewer Service Connection Fee

- I. A Connection Fee shall be paid **for the connection of each new water and sewer service to the system.** This fee must be paid even if a service line has previously been stubbed to the property line or other accessible location. Connection Fees for water and/or sewer must be paid before a Certificate of Occupancy will be issued by the Building Department and before service is approved. Connection Fees are established by City Ordinance.

#### 1.1.9 Applicable Laws and Indemnification of the City

- A. To the fullest extent permitted by law, the permittee shall fully indemnify, defend, and save the City, its agents, representatives, employees, and officers harmless from and against any and all claims, actions, costs, fees, losses, liabilities or damages of whatever kind or nature arising from or related to the permittee's performance of the permitted excavation and the permittee's work, or work of any subcontractor or supplier to applicant (OCCGF Title 12); and
- B. The Contractor shall give all notices and comply with all federal, state and local laws, ordinances and regulations affecting the conduct of the work.

#### 1.1.10 Interruption of Service

- A. Any construction that will interrupt the normal operation of city sewer, water, storm, or transportation facilities requires notification of affected City departments and property owners and/or residents. The Contractor shall notify the PWD Engineering Division (Phone 406-771-1258) at least 2 business days prior to any street or alley closures;
- B. All street closures or interruptions of utility services will require the Contractor to provide information specifying the location of construction and the duration of the closure;
- C. The Contractor shall present the news release to the news media at least 2 business days prior to the beginning of any construction activity; and
- D. The Contractor shall also notify utility users affected by the interruption of the type and duration of the interruption at least 2 workdays prior to beginning construction.

#### 1.1.11 Traffic and Pedestrian Control

- A. In the event of an emergency interruption, the Contractor shall notify the PWD, Police and Fire Departments immediately. The Contractor shall immediately dispatch members of his staff to notify affected individuals by telephone, letter, or personal contact;
- B. A Traffic and Pedestrian Control Plan shall be submitted to the PWD for all work within the public right-of-way:
  - I. Conform to the latest edition of the [Manual on Uniform Traffic Control Devices \(MUTCD\)](#);
  - II. Show the location and description of all Traffic and Pedestrian Control Devices;
  - III. No work shall commence on the project until the plan is approved;
  - IV. Keep all devices in place and maintained throughout the project;
  - V. Temporary pedestrian walkways shall meet the requirements of the Americans with Disabilities Act (ADA); and

- VI. The PWD reserves the right to reject any device observed to be in substandard condition.
- C. Emergency access to the work area shall be maintained at all times;
- D. All barricades and obstructions shall be protected at night by suitable signal lights which shall be kept illuminated from sunset to sunrise. Barricades shall be of substantial construction and shall be constructed to increase their visibility at night. Suitable warning signs shall be placed to show in advance where construction, barricades or detours exist. All signs used at night shall be either retro-reflective with a material that has a smooth, sealed outer surface or illuminated to show the same shape and similar color both day and night;
- E. If flagging is required it shall be accomplished by competent and properly equipped flag persons. Flagging shall be accomplished as described in the Montana Department of Transportation Flagger's Handbook and the MUTCD;
- F. Traffic control devices shall be removed from visual contact with the traveling public when they are not being used for construction activities;
- G. The Contractor shall remove all traffic and pedestrian control devices within 24 hours of the conclusion of the project construction; and
- H. If the Contractor fails to maintain the Traffic and Pedestrian Control Devices in accordance with the regulations provided in the MUTCD, the City reserves the right to issue a stop work notice effective until issues have been corrected.

1.1.12 Liability Insurance (OCCGF Title 12)

- A. Before any application to excavate, cut, access or tear open any public way is granted, such applicant shall furnish satisfactory evidence the applicant's activities are properly covered by applicable insurance coverage in amounts that shall be set by City Commission resolution and shown below.

**COMMERCIAL GENERAL LIABILITY**

Each Occurrence (bodily injury and property damage) \$1,500,000

**AUTOMOBILE LIABILITY**

Includes Scheduled, Hired, &

Non-Owned Autos \$1,500,000 Combined Single Limit

**WORKERS' COMPENSATION**

Workers' Compensation Not less than statutory limits

Employer's Liability \$1,000,000

**UMBRELLA COVERAGE**

Applicant may provide applicable excess or umbrella coverage to supplement Applicant's existing insurance coverage, if existing policy limits do not satisfy the coverage requirements as set forth above.

1.1.13 Bonding (OCCGF Title 12)

- A. All construction work within the public right-of-way or easement (sidewalk, boulevard, pavement, curb construction, water, storm drainage, sanitary sewer service line

installation, repair, etc.) will require the Contractor to have the required license and to provide the P&CD Department with a Performance Bond in the amount of \$5,000 and shall remain in force for two years;

- B. The bond must include a Compliance Guarantee; a Good Faith Guarantee and an Indemnity Guarantee;
- C. Bonds may be in the form of a Surety Bond, a Certified Check, or an irrevocable Letter of Credit issued by a bank licensed to do business in the state of Montana;
- D. Be payable to the City and/or State as their interests appear with respect to the expenditure of funds toward the construction of the street, avenue, alley, sidewalk, boulevard, or public way within the City;
- E. Be conditioned for the protection of the City and/or State from and against any liability of any kind or character whatsoever which may arise as a result of the applicant's excavating in, cutting through, or opening up any such street, avenue, alley, sidewalk, boulevard, or other public way or which may in any way or manner be connected with or related thereto, payable by the applicant;
- F. Be further conditioned that the permittee shall properly backfill and restore the surface of any and all excavations, openings, or cuttings made or dug in the public ways of the City, and shall do and complete all work in connection therewith in a good, competent, and workmanlike manner and in compliance with the specifications required therefore by the City and/or State; and
- G. Remain on file with the PCD Department; or
- H. Include a water service line layer's license bond under the provisions of OCCGF Title 13, or a drain layer's license bond under the provisions of OCCGF Title 13, and the conditions of either of such bonds shall be amended to include the conditions as required by this section.

1.1.14 Guarantee for Equipment, Materials, and Workmanship

- A. The Contractor shall guarantee all materials and equipment furnished, and construction work performed for maintenance and repair work on **existing city infrastructure** for a period of 2-years from the date of written acceptance of the work by the CoGF;
- B. The guarantee for **new city infrastructure** shall be for a period of 2-years from the date of written acceptance of the work by the CoGF. In the case of a subdivision, the date of acceptance will be final plat approval or acceptance by the PWD, whichever is later; and
- C. Guarantees shall be in the form of a Maintenance bond:
  - I. Required prior to Final Plat or Certificate of Occupancy as may be deemed appropriate by the Director of Public Works;
  - II. Equal to the percentage stated in the OCCGF Title 17;
  - III. Shall remain in force throughout the guarantee period;
  - IV. The City reserves the right to draw on the maintenance bond for repairs not completed by the responsible party within 30 calendar days of being advised that repairs are required;
  - V. Maintenance bonds may be in the form of a Surety Bond, a Certified Check, or an irrevocable Letter of Credit issued by a bank licensed to do business in the state of Montana; and
  - VI. The Commencement Date for the Maintenance Bond shall be the date set for the completion of the required improvements as stated in the Subdivision



Improvements Agreement, the date of Substantial Completion as certified by a Professional Engineer, or the date Final Plat is granted, whichever is later.

1.1.15 Excavation and Disposal of Material from Existing Public Right-of-Way and Easement

- A. All material unsuitable, including but not limited to petroleum contaminated soil, for trench backfill, sub-base or base construction, excavated from the developed public right-of-way or easement shall be removed from the site and legally disposed of by the Contractor;
- B. The disposal site shall meet Federal, State, County, and Local regulatory provisions for disposal of the unsuitable excavated material;
- C. Unsuitable excavated material shall not be stockpiled on site without the written approval of the PWD; and
- D. Excavated material shall be confined to the work zone as established during the preconstruction conference, the public right-of-way, or as shown in the contract documents.

1.1.16 Intersection Monuments

- A. When a street is to be reconstructed, prior to any excavation, a thorough search shall be made for existing intersection monuments. If found, such monuments and any other survey monuments likely to be disturbed or destroyed, shall be preserved by or under direction of a Professional Land Surveyor in accordance with [MCA 70-22-115](#); and
- B. All monuments set shall meet the requirements of [ARM 24.183.1101](#). Monuments set in pavement or concrete driving surfaces shall be placed inside of a cast iron monument box, per CoGF Standard 5-01.

1.1.17 Pollution Controls

- A. During all construction in the right-of-way, the Contractor shall be responsible to maintain the construction site and all haul routes in accordance with the requirements of the CoGF's Storm Drain Design Manual (See Chapter 7) and all applicable state and federal permits;
- B. Excavation dewatering, disinfected water, petroleum contaminated water, or sediment laden run-off discharges to the storm drain or sanitary sewer are prohibited without the applicable permit or written authorization form the City MS-4 program or Industrial Pretreatment Program; and
- C. See Chapter 7 of this document for more information on storm water quality and quantity requirements and permitting.

1.1.18 Pavement Restoration

- A. All work shall be accomplished in accordance with current MPWSS and these Standards;
- B. See Chapter 8 of this document for more information on pavement restoration requirements;
- C. All excavations within 4 feet of the edge of the asphalt (including the outer edge, the crown, or adjacent seam) shall require removal and replacement from the edge of asphalt to the excavation edge. Asphalt patch areas that fall within the wheel path of the

vehicular travel lane shall be increased in size to the center of the lane or adjacent lane. In no circumstance will the edge of a patch area be allowed to fall within the wheel path;

- D. Any damage to the existing asphalt surface caused by the Contractor's operations shall be repaired at the expense of the Contractor, including but not limited to gouges, scrapes, outrigger marks, and bucket marks. A slurry seal shall be considered the minimum standard for a repair to existing surfacing;
- E. The Contractor shall be responsible for maintaining the area in a smooth and drivable condition until the permanent pavement is placed. If the ground is frozen, the road cut shall be temporarily repaired with a minimum thickness of 4-inches of flowable fill or a minimum thickness of 4-inches of cold patch material. The temporary repair shall be maintained by the Contractor for safe winter usage. The permanent restoration shall be made as soon as the ground is thawed in the spring, or as directed by the PWD; and
- F. If the Contractor fails to restore the pavement within the 14-day period, or fails to maintain the trench or area as required, the City reserves the right to complete the restoration or maintenance, and all labor, equipment, material and administrative costs will be billed to the Contractor. The City reserves the right to call on the Contractor's Performance Bond if the bill is not paid within 30 days.

#### 1.1.19 Stop Work Order

- A. A written Stop Work Order may be issued by the PWD if the work in progress does not meet the Standards for the CoGF, or for any other valid reason; and
- B. Work may resume only after a written Resume Work Order has been issued by the PWD.

#### 1.1.20 Relocation of Utilities

- A. Requests to relocate an existing public utility shall be submitted in writing to the PWD. A sketch shall be included that illustrates the existing location of the utility and the preferred relocation site. The request shall describe, in detail, the circumstances for the request;
- B. Utility relocation shall be designed by a licensed professional engineer;
- C. If the relocation is approved by the PWD, the utility shall be relocated by a bonded and insured utility contractor (see Section 1.1.12 and 1.1.13). Under no circumstances will the CoGF pay for any costs associated with the relocation of the utility; and
- D. Relocation of water and sewer mains are also subject to MDEQ review and approval.

## **1.2. PROJECT REQUIREMENTS**

### 1.2.1 Contractors Requirements

- A. Registration:
  - I. Any Contractor working within an existing Public Right-of-Way or Easement shall be registered with the Montana Department of Labor and Industry, Employment Relations Division.
- B. Insurance and Bonding:
  - I. Insurance and bonding shall be in accordance with Sections 1.1.12 and 1.1.13 as applicable; or
  - II. As required in the City of Great Falls Construction Agreement when the project includes such agreement;

C. Preconstruction Meeting:

- I. Prior to the start of any construction on public works infrastructure that will be dedicated to the City and reviewed under the infrastructure review fee, a preconstruction conference shall be held. The PWD, the Project Engineer, the Contractor, and any other parties pertinent to the project shall be represented. Items to be discussed at the pre-construction conference are construction schedule, shop drawing submittals, utility installation, materials testing, quality control, maintenance bond, and other items as may be necessary; and
- II. A paper copy and a digital copy of the plans approved by MDEQ (when applicable), three (3) paper copies and a digital copy of the City approved plans, and two (2) paper copies and a digital copy of shop drawing submittals approved by both the Project Engineer and the Contractor shall be submitted to the City Engineering Office prior to scheduling the Preconstruction meeting; and
- III. The person(s) requesting the Preconstruction meeting shall provide the additional applicable items listed on the Preconstruction meeting checklist and deliver the completed Preconstruction meeting agenda template documents located in Appendix F of these standards to the City Engineering Office prior to scheduling the Preconstruction meeting.

D. Shop Drawing Submittal:

- I. If the proposed items to be installed differ from the approved plans and specifications, the design engineer shall notify the City Engineering Office of the proposed revision and shop drawings shall be submitted for review not later than 10 business days prior to the proposed installation.

### **1.3. CONSTRUCTION STANDARDS**

#### **1.3.1 Underground Utilities**

- A. All underground electrical, gas, phone, and TV cable lines must be installed at least 10 feet horizontally from water, sanitary sewer and storm sewer mains and at least 5 feet horizontally from water, sanitary sewer, and storm sewer services.

### **1.4. CONSTRUCTION INSPECTION, TESTING, AND QUALITY CONTROL**

#### **1.4.1 Construction Inspection**

- A. A Professional Engineer, or the Professional Engineer's designated representative, shall provide construction inspection and testing as required. Failure to submit required testing and other documentation shall be considered valid justification for non-acceptance of construction work and/or public infrastructure. Inspection and testing shall be in accordance with the current edition of the MPWSS and the Standards; and
- B. The following quality control procedures will apply to all utility and roadway construction projects. The City reserves the right to conduct independent quality assurance testing at the City's expense during any phase of the construction. The Contractor shall bear the expense of failed tests and the expense of bringing the material into conformance with the required specifications.

- I. All water main valves and fittings, fire hydrants, sewer manholes, wet wells and sewer/water main crossings shall be inspected and approved by the Professional Engineer, or his designated representative, prior to backfilling;
- II. Water and sewer construction testing shall be performed in accordance with these Standards, MDEQ, AWWA, and MPWSS;
- III. A Professional Engineer, or the Professional Engineer's designated representative, shall be present for all tests required in Sections 02660, 02720, and 02730 of the MPWSS. A written record of all test results shall be submitted to the PWD and certified by the Professional Engineer of record for the construction; and
- IV. A Professional Engineer, or the Professional Engineer's designated representative, shall provide the PWD with photocopies of daily inspection reports, including Proctors and compaction test results for all projects. These reports shall be submitted on a weekly basis and certified by the Professional Engineer of record for the construction.

#### 1.4.2 Compaction Testing

- A. The following minimum compaction testing procedures shall apply to all utility and roadway construction projects. A testing laboratory or engineering firm personnel as approved by the City shall be retained to provide the following tests and frequency. Random longitudinal test locations are required. The following are minimum compaction test requirements. The Professional Engineer, or the Professional Engineer's designated representative, may require additional tests. For projects containing less than 300 linear feet of improvements, a minimum of one compaction test for each improvement shall be required for the improvements listed below.
  - I. Utility Trenches and Underground Structures:
    - a. Set of Tests:
      - i. For trenches up to 8 feet in depth, density tests shall be taken at 24 inches above the pipe, at one-half the trench depth, and at the surface.
      - ii. For trenches greater than 8 feet in depth, density tests shall be taken at 24 inches above the pipe, at one-third and two-third the trench depth levels, and at the surface.
    - b. The minimum density shall be 95% Standard Proctor,  $\pm$  3% optimum moisture.
    - c. Horizontal Frequency:
      - i. Utility Mains – One set of tests per 150 feet.
      - ii. Service Lines – One set of tests per 3 services, per utility type.
      - iii. Open Pit – Minimum of one set of tests (Open Pit – at each manhole, water valve, storm inlet, curb inlet, vault, etc.)
    - d. Each test location shall be separated horizontally from a prior test location.
  - II. Street Subgrade:
    - a. All sub-base: 95% Standard Proctor,  $\pm$  3% optimum moisture. One random density test, every 100 linear feet of street per lane with random offsets.

- b. All crushed gravel base: 95% Standard Proctor,  $\pm$  3% optimum moisture. One random density test, every 100 linear feet of street per lane with random offsets.

III. Asphalt Surface:

- a. Pavement and material testing requirements shall be in accordance with Section 1.4.1 and MPWSS Section 02510 Paragraph 3.28 and 3.29, except:
  - i. Add subsection 3.28I to the standard as follows: “Asphalt compaction samples will be taken according to AASHTO T 230 and tested in accordance with AASHTO T 166. One location per lane per block as determined by the Engineer shall be required.
  - ii. Subsection 3.29E shall be replaced with: “The field density and thickness of the pavement is determined by measuring the cores tested. The actual thickness shall not be less than the design thickness, and shall in no case be less than four (4) inches.”
  - iii. Subsection 3.29F shall be replaced with: “Asphalt thickness shall be measured using full depth core samples. Thickness shall be measured from the surface of the specimen to the bottom of the uniform plant mix which thickness shall not include foreign materials, seal coat, foundation material, soil, paper or foil. Thickness less than specified thickness as measured on the acceptance sample shall be subject to rejection for the lane and block from which the specimen was taken as determined by the Engineer.”

1.4.3 Video Inspection

- A. The City shall conduct a video inspection paid for by the contractor for sewer mains;
- B. The contractor shall flush the main with water immediately prior to inspection;
- C. Manholes and laterals shall be included in the video inspection;
- D. Upon review of the video inspection by the authorized City representative, any deficiencies found shall be corrected by the contractor prior to final acceptance;
- E. The CoGF reserves the right to inspect all underground utility systems by the use of a television camera prior to final acceptance; and
- F. The cost of all video inspections by City staff will be billed to the contractor.

1.4.4 Portland Cement Concrete Testing

- A. Use ACI Grade 1 or equivalent certified field testing technicians for all concrete tests. One set of tests shall be required for every 50 cubic yards of concrete placed within the public right of way, with a minimum of one set of tests per day of concrete placed. Curb and gutter, sidewalks, driveways, approaches, curb turn fillets, valley gutters, and other miscellaneous new surface concrete construction shall be constructed with 6.5 sac cement and have a 28 day strength of 4,000 psi, with an air entrainment between 5% to 8%. The concrete tests shall be performed in accordance with MPWSS Section 03310 Paragraph 3.6.

- B. In no case will the average 28 day strength of one set of tests (average of three 4 inch diameter cylinders or two 6 inch diameter cylinders cast from one composite sample) be less than 4,000 psi, statistical acceptance methods based on consecutive sets of tests will not be allowed.

## **1.5. BOULEVARD LANDSCAPING**

### **1.5.1 Requirements**

- A. Refer to the OCCGF Title 17 for requirements.
- B. Boulevard landscaping shall be placed in accordance with the CoGF landscape requirements (OCCGF Title 17) and a plan approved by the CoGF Planning and Community Development Department (406-455-8430).

## **1.6. RECORD DRAWINGS AND PROJECT ACCEPTANCE**

### **1.6.1 Certification**

- A. Upon project completion and before final acceptance, a Professional Engineer shall certify that the construction of the water, sewer and storm utilities and roadways meet the requirements of the approved construction documents.

### **1.6.2 Record Files**

- A. The Design Engineer or developer shall submit one full-size set of 4-mil Mylar Record Drawings (or approved equal) and a PDF copy and a copy of the DWG in digital format and one set of the test results required under Section 1.4 to the PWD. This does not include submitting test results collected by the City. For example, the Design Engineer or developer shall submit a copy of the concrete strength testing results.

### **1.6.3 Acceptance**

- A. The City will not accept the project until record drawings and test results have been approved by the City Engineer;
- B. The Project Engineer shall provide the City Engineer's Office with quantities and unit costs of all infrastructure installed that is tied to a reimbursement; and
- C. The owner shall submit a letter requesting ownership transfer of the newly constructed public infrastructure to the City (See Appendix A – Example Ownership Transfer Letter).

## **1.7. TWO-YEAR GUARANTEE INSPECTION FOR PROJECTS**

### **1.7.1 Requirements**

- A. The Project Engineer, or his designated representative, shall conduct a two-year guarantee inspection, to be attended by a representative from the PWD;
- B. The inspection shall take place not less than 90 days or more than 120 days prior to the expiration date of the Maintenance Bond; and
- C. The maintenance bond will be released when all deficiencies have been corrected to the satisfaction of the City Engineer.

1.7.2 Warranty Work

- A. The City Engineer, the Project Engineer, or the designated representative, shall notify the Principal as listed in the Maintenance Bond of any work found to be not in accordance with the approved construction documents;
- B. The Principal shall restore the work to meet the requirements of the approved construction documents prior to the release of the Maintenance Bond; and
- C. The City expressly reserves the right to draft the Maintenance bond for repairs not completed by the Owner, Developer, or Contractor within thirty calendar days of being advised that repairs are required.

# CHAPTER 2 - DESIGN CRITERIA



## Chapter 2 Design Criteria

### 2.1. PLANS

#### 2.1.1 General Items

- A. Coordinate System:
  - I. Montana State Plane – International Foot.
- B. Datum:
  - I. North American Vertical Datum 1988 (NAVD 88) with conversion factor (typically 19.15 feet higher than City) to City Datum; or
  - II. City of Great Falls Datum.
- C. Contours:
  - I. Improved Areas:
    - a. 5-foot major contour interval (max);
    - b. 1-foot minor contour interval (max); and
    - c. The CoGF reserves the right to request smaller or larger contour intervals for clarity if necessary.
  - II. Unimproved Areas:
    - a. 10-foot major contour interval (max);
    - b. 2-foot minor contour interval (max); and
    - c. The CoGF reserves the right to request smaller or larger contour intervals for clarity if necessary.
  - III. Existing contours shall use a dashed line-style;
  - IV. Proposed contours shall use a continuous line-style; and
  - V. Major contour lines shall be thicker than minor contours and include elevation labels.
- D. Alignment Data:
  - I. Coordinate data shall be provided for:
    - a. Beginning of alignment;
    - b. Alignment changes in direction; and
    - c. End of alignment.
  - II. Provide the following curve data:
    - a. Length of curve;
    - b. Curve Radius; and
    - c. Chord bearing and length.
  - III. Bearings and distances:
    - a. Provide between points on alignments.

#### 2.1.2 Title Sheet(s) (Shall not exceed 3 Sheets):

- A. Project Title;
- B. Vicinity Map:
  - I. Project Limits;
  - II. Adjacent Street Names;
  - III. North Arrow; and
  - IV. Scale Bar.
- C. Firm or Engineer Information:

- I. Name;
- II. Address; and
- III. Telephone Number.
- D. MT Professional Engineer Stamp;
- E. Point and Line Style Legend;
- F. Property Address and Legal Description, Including:
  - I. Lot, Block, Subdivision Name;
  - II. Township;
  - III. Range; and
  - IV. Section(s)
    - a. If contained within a single section, provide the  $\frac{1}{2}$ ,  $\frac{1}{4}$ , or  $\frac{1}{4} \frac{1}{4}$  information as applicable (e.g. SW  $\frac{1}{4}$  NE  $\frac{1}{4}$ ).
- G. Table of Contents or Sheet Index.

### 2.1.3 Plan Sheets

- A. Project Title;
- B. Sheet Title;
- C. Sheet Number;
- D. MT Professional Engineer Stamp;
- E. Revision Data (See Section 3.1.2);
- F. North Arrow (True North or CoGF North); and
- G. Scale Bar
  - I. Set to Standard Engineering Scales.

### 2.1.4 Plan and Profile Sheets

- A. Shall be provided for all proposed water main, sanitary sewer main, storm main, and streets;
- B. Include all items in Section 2.1.3 above; and
- C. In profile show:
  - I. Vertical scale;
  - II. Proposed ground;
    - a. Continuous line-style;
  - III. Existing ground;
    - a. Dashed line-style.
  - IV. Crossings of other utilities and separations from them;
  - V. Parallel utilities shall be shown in grayed line-style;
  - VI. Pipe:
    - a. Size and Length;
    - b. Slope (if gravity); and
    - c. Material type.
  - VII. Bury depth;
  - VIII. Groundwater depths (if identified);
    - a. Include date of recording.
  - IX. Structures and Appurtenances;
    - a. For Water:
      - i. Valves, fittings, services, fire hydrants, encasement, etc.

- a) Label size and type; and
    - b) Provide station and offset or coordinates.
  - b. For Sanitary Gravity Sewer:
    - i. Manholes, services, and other structures
      - a) Label invert elevations;
      - b) Label rim elevations; and
      - c) Provide station and offset or coordinates.
  - c. For Sanitary Force Mains:
    - i. Valves, fittings, air/vacuum valves, and other structures
      - a) Label size and type; and
      - b) Provide station and offset or coordinates.
  - d. For Storm Sewer:
    - i. Manholes, catch basins, and other structures:
      - a) Label invert elevations;
      - b) Label rim and grate elevations; and
      - c) Provide station and offset or coordinates.
- X. Streets, roads, and pathways:
  - a. Centerline grades, grade break (PVI) locations and centerline elevation, existing grades and elevations at connections;
  - b. Vertical curve data
    - i. VPI Station and elevation;
    - ii. Length;
    - iii. Radius; and
    - iv. k-value.
  - c. TBC grades shown in profile view if super-elevation or warping occurs
- XI. Stormwater conveyance system:
  - a. Show all pipes, culverts, ditches, and connections; and
  - b. Include all sizes, material types, lengths, slopes, and invert elevations.
- D. Shall include existing utilities and structures, including where appropriate; line size and material, valves, fittings, hydrants, manholes, service lines, inlets, gas lines, electric lines, telephone poles, light poles, junction boxes, irrigation systems, communication lines, private utility lines and appurtenances, proposed connection to existing utility locations and field verified invert elevations.
- E. Shall show proposed dry utilities, including where appropriate; gas lines, electric lines, communication lines, telephone poles, light poles, junction boxes, sleeves and conduits, utility connection points, and other proposed dry utility lines and appurtenances

#### 2.1.5 Detail Sheets

- A. Provide applicable CoGF Standard Details;
  - I. Highlight any additions, deletions, or modifications to CoGF Standard Details.
- B. Include the following:
  - I. Project Title;
  - II. Sheet Title;
  - III. Sheet Number;
  - IV. Scale;
  - V. MT Professional Engineer Stamp; and

VI. Revision Data (See Section 3.1.2).

2.1.6 Road and Drainage Plans

- A. Include all items in Section 2.1.3 above;
- B. Include the following:
  - I. Existing and proposed contours;
  - II. Crest and sump point elevations;
  - III. Flow arrows;
  - IV. Record drawing information;
  - V. Construction details or standard detail for all structures;
  - VI. Drainage Easements;
    - a. If existing, provide recording number.
  - VII. Where swales, ditches, or channels interfere with driveway locations:
    - a. Driveway locations shall be fixed and shown on the plans.
  - VIII. Existing and proposed lot grading plans.
  - IX. Top back of curb spot elevations for all PCs, PTs, PCCs, grade breaks, connections to existing curbs, and inlets.
  - X. Typical Street Sections.
  - XI. Radius of intersection curbs.
  - XII. Signage and Striping Plans as needed. Coordinate with CoGF Traffic Foreman (406-781-8991).

2.1.7 Drainage Facilities and Swales

- A. Include all items in Section 2.1.3 above;
- B. Provide a cross-section of each pond or swale, including the following:
  - I. Bottom elevation;
  - II. Structure elevations;
  - III. Maximum water surface elevation;
  - IV. Inlet and outlet elevations; and
  - V. Berm elevations and slopes.
- C. Landscaping and vegetation requirements;
- D. Compaction requirements;
- E. Keyway locations and dimensions;
- F. Coordinates and elevations of pond corners, swale/ditch angle points, inlet/outlet pipes, and all drainage structures; and
- G. Material gradation, thickness, and dimensions of riprap pads.

2.1.8 Basin Maps

- A. Required as part of the Drainage Submittal
- B. Provide Pre-development and Post-development
- C. Minimum elements:
  - I. Vicinity map, project boundaries, PLSS information;
  - II. Delineated runoff basin limits with weighted C coefficients, if applicable:
    - a. Include on-site, off-site, and bypass areas contributing runoff to or from the project;

- b. Engineer shall field-verify basin limits, including off-site areas, and describe how the limits were determined; and
    - c. Shall be clearly labeled and correlate with calculations.
- III. Time of concentration routes with each segment clearly labeled and correlated with calculations;
- IV. Contours:
  - a. Shall extend beyond the project or drainage basin as necessary to confirm basin limits; and
  - b. Refer to Section 2.1.1C.
- V. Any drainage way, including natural drainage ways, constructed drainage features, wetlands, creeks, streams, seasonal drainage ways, closed depressions, ditches, culverts, storm drain systems, and drywells;
- VI. Floodplain limits as defined by FEMA or other studies;
- VII. Geologically hazardous areas;
- VIII. Proposed drainage features;
- IX. North arrow and scale;
- X. Existing and proposed easements, parcel land, open space, and parkland; and
- XI. Adjacent streets.

# CHAPTER 3 - PROJECT SUBMITTALS

## Chapter 3 Project Submittals

### 3.1. PROCESS

#### 3.1.1 Submittals

##### A. Civil Plans:

- I. Shall be submitted to PCD with the accompanying infrastructure review fee, if applicable, as outlined in Chapter 1 of these Standards with 2 hard copies;
- II. Shall be provided in electronic PDF format;
- III. The Professional Engineer(s) responsible for the civil design portions of the project shall stamp the project cover sheet, or each individual sheet of the civil design; and
- IV. Include the general checklist as well as other applicable checklists.
  - a. Checklists are available (call 406-771-1258 for additional info.).

##### B. Reports and Specifications:

- I. Shall be submitted to PCD with 1 hard copy;
- II. Shall be provided in electronic PDF format;
- III. Submit separate documents in the following order (as applicable):
  - a. Project Manual or Applicable Specifications
  - b. Water Design Report
  - c. Sanitary Sewer Design Report
  - d. Storm Drainage Design Report
  - e. Traffic Impact Study, if required per Section 8.1.2
- IV. The Professional Engineer(s) responsible for the individual sections specified above shall stamp the front cover of each separate document.

##### C. It is recommend that water and sanitary sewer system designs be approved prior to submitting to MDEQ for review; and

##### D. The CoGF shall attempt to complete the initial review and provide written comments to the Development Team within thirty (30) calendar days of receiving a complete initial submittal.

- I. Contact the project permit coordinator in PCD for what the requirements are for a submittal to be deemed complete;
- II. A review meeting may be scheduled to discuss review comments if the design Engineer desires; and
- III. Pre-design and interim meetings with the design Engineer and City Engineering staff are encouraged.

#### 3.1.2 Resubmittals

##### A. Civil Plans

- I. Individual sheets may only be provided with written approval from the CoGF engineer reviewing the Civil Plans;
- II. All changes shall include revision clouds; and
- III. Revision notes shall be provided on the sheet including:
  - a. Revision number
  - b. Revision date
  - c. Any applicable notes

- B. Reports and Specifications:
  - I. Shall be submitted to PCD with 1 hard copy;
  - II. Shall be provided in electronic PDF format;
  - III. The resubmittal shall be the entire report or specification; and
  - IV. The Professional Engineer(s) responsible for the individual sections specified in Section 3.1.1 above shall stamp the front cover of each separate document.
- C. The CoGF shall attempt to complete the subsequent review and provide written comments to the Development Team within thirty (30) calendar days of receiving a complete subsequent submittal.
  - I. Contact the project permit coordinator in PCD for what the requirements are for a submittal to be deemed complete; and
  - II. A review meeting may be scheduled to discuss review comments if the design Engineer desires.

### 3.1.3 Delivery

- A. Provide digital files and paper copies to the front desk of the CoGF Planning and Community Development Department.
- B. Call 406-455-8430 for more information.

### 3.1.4 Approval

- A. Once all CoGF review comments have been adequately addressed and resolved the developer shall provide City Staff:
  - I. Two (2) complete sets of the correctly scaled site civil final plans, signed and stamped by a PE (sheet size dictated by plan reviewer);
  - II. One hard copy of the final reports and specifications, signed and stamped by a PE (reports and specifications shall contain the current version of the revised documents and plan sheets); and
  - III. An electronic version of the approved plans, reports, and specifications (signed and stamped by a PE) shall be provided in PDF format.
- B. Final stamped and approved plans will be distributed as follows:
  - I. One set for CoGF Engineering Division;
  - II. One set for CoGF Engineering Division Field Inspector; and
  - III. One set provided to Contractor to be kept on site during construction.

## **3.2. RESPONSIBILITIES**

### 3.2.1 Professional Engineer

- A. Meet the minimum design standards as specified or referenced herein during design;
- B. Verify compliance with the minimum construction standards as specified or referenced herein during construction;
- C. Coordinate with Contractor, City Engineering Staff, and other local, state, and federal agencies to resolve issues that arise during construction and, if needed, prepare modified plans for review and approval; and
- D. Prepare and provide PW Engineering Division and MDEQ with record drawings.



### 3.2.2 Contractor

- A. Meet the minimum construction standards as specified or referenced herein;
- B. Provide PW Engineering Division with 2 paper copies and a digital copy of the project submittals that have been reviewed and approved by both the Contractor and the Design Engineer;
- C. Attend the pre-construction meeting;
- D. Notify the PW Engineering Division (406-771-1258) a minimum of 48 hours before starting construction;
- E. Ensure that a City Inspector is on site during construction of all work requiring inspections; and
- F. Provide the PW Engineering Division with copies of all third party testing results.

### 3.2.3 City Engineering Staff (Type I) or Third Party Consultant (Type II)

- A. Review the design and construction to verify compliance with current Standards;
- B. Provide full time inspection of the public improvements;
  - I. The full time inspector cannot authorize any deviation from the approved plans and specifications or substitution of materials or equipment, unless authorized by the Design Engineer and approved by the City Engineer or his/her designee.
- C. Provide the Design Engineer with red line notes of changes that occurred during construction; and
- D. Provide a copy of the “built in substantial accordance with the MDEQ approved plans” certification letter required by MDEQ.

### 3.2.4 Developer

- A. Employ a Professional Engineer to design the project or development in accordance with the minimum design standards as specified or referenced herein;
- B. Employ a contractor to meet the minimum construction standards as specified or referenced herein; and
- C. Employ a Professional Engineer (CoGF Engineering Staff) to verify compliance with minimum construction standards throughout construction of all proposed CoGF infrastructure within the development.
  - I. Type I – CoGF Engineering Staff
  - II. Type II – **Third Party** Consultant (only allowed with City Engineer approval)

### 3.2.5 All Parties

- A. If at any point of design or construction, an unapproved deviation from the Standards is realized by the Engineer, Contractor, the CoGF, or the Developer, immediate action shall be taken to correct the issue and bring the design or construction into compliance with the standards currently in effect at no cost to the CoGF; and
- B. Any changes from approved drawings shall be reviewed, stamped, and approved in writing by the Design Engineer first, then CoGF PWD Engineering Staff, prior to construction of said change.

### **3.3. DESIGN OR CONSTRUCTION DEVIATION**

#### **3.3.1 Requirements:**

- A. A Deviation will only be granted when minimum standards cannot be met or when the proposed item meets or exceeds minimum standards as determined by the City Engineer. Deviations will not be considered on basis of cost, “engineering judgment”, or “professional opinion”;
- B. Requests shall be made in writing and shall:
  - I. Identify the specific section of the standards requiring a deviation;
  - II. State the standard as currently adopted;
  - III. State the standard as proposed for the deviation; and
  - IV. Provide adequate justification for the deviation.
- C. Requests shall be approved by the CoGF PWD Engineering staff in writing; and
- D. Deviations from the Standards not individually approved as indicated above are not approved, even if shown in approved plans, specifications, or reports.

# CHAPTER 4 - DEVELOPMENT

## Chapter 4 Development

### 4.1. REQUIREMENTS

#### 4.1.1 General

- A. All subdivisions and developments shall comply with MDEQ requirements, the Official Code for the CoGF, and these Standards;
- B. Roadways and utilities shall be constructed from the existing facilities to the far property line of the development or such other point within the development that may be specified by the City Engineer:
  - I. Extension of water mains beyond the property line may be required as determined by the City Engineer for looping and redundancy; and
  - II. All utilities shall be within a public right-of-way or easement to permit free and unobstructed access.
- C. Obtain and provide the City with all easements and right-of-ways necessary to extend roadways and utilities to the far property line of the development:
  - I. Obtain written approval from the CoGF PWD stating they have reviewed and approved the location of easements for the future extension of roadways and utilities which shall be submitted with the final plat along with an 11 x 17 legible copy of the approved final plat showing the utility and/or easement locations.
  - II. An easement benefiting the City of Great Falls that is created on a final plat shall have the following language:

“Acceptance of shown new City of Great Falls easements:

A perpetual easement benefiting the City of Great Falls for the construction, maintenance, enlarging, reducing, replacing, or removal of underground utilities including above ground fire hydrants, valve boxes, and lids for accessing underground utilities, together with all necessary appurtenances thereto, in, under, through and across the real property shown on this plat together with the right to excavate and refill ditches and/or trenches throughout the location of said general utilities. The City of Great Falls or its designee agrees that in the event of any excavation within said easement for purpose of maintenance or repair, the area shall be backfilled and/or restore the surface to its then existing condition. For the protection of said easement, the property owner shall not make or construct any buildings, retaining walls, trees, shrubs, bushes, or other structures (including other utilities) that would impair the maintenance or operation of the utilities placed therein. Asphalt and Portland cement concrete paving, grass, traffic signs, mail boxes, fences, irrigation sprinkler systems are permissible improvements within the land covered by this easement. This grant of easement shall run with the land and shall be binding upon and shall inure to the benefit of the City of Great Falls, Montana its successors and assigns.

To the fullest extent permitted by law, the property owner shall indemnify, defend, and save City, its agents, representatives, employees, and officers harmless from and against any and all claims, costs, fees, losses, liabilities or damages of whatever kind or nature arising from or related to property owner’s use of the real property described herein, except for the City’s actions under this grant of easement.”

- D. There should be reserved along the front lot line and side street lot line of each residential and commercial lot a 10-foot wide utility easement along, contiguous and adjacent to the lot line to provide an area between the lot line and the easement line for the placement of privately owned underground utilities.

#### 4.1.2 Utilities

- A. All new utilities that can be placed underground should be placed underground, unless written permission is provided by the City Engineer;
- B. City utility collection and distribution mains shall be located within the paved portion of the street or alley;
- C. Water transmission mains, sewer interceptor mains, and sewer force mains shall be located as approved by the City Engineer;
- D. Underground private utilities, including fiber optic communication lines, should be located on private property between the lot line and the easement line, unless written permission is provided by the City Engineer;
- E. No underground utilities, except service sweeps to the streetlights shall be placed parallel to the roadway in the boulevard between the back of curb and sidewalk or within a sidewalk itself;
- F. No aboveground utility boxes, pedestals, vaults, or transformers shall be placed within any City utility easement or access easement to any City facility, unless written permission is provided by the City Engineer; and
- G. Streetlights shall be at least 2 feet from the back of curb. All above ground utilities shall be at least 1 foot from the sidewalk.

#### 4.1.3 City Utility Easements:

- A. All City utility easements shall be 20 feet wide for a single pipeline, with the pipe centerline 10 feet from one easement edge;
- B. For easements with two pipelines, the minimum width shall be 30 feet with each pipe centerline 10 feet from the easement edge; and
- C. For easements with three pipelines, the minimum width shall be 40 feet with each pipe centerline 10 feet from the easement edge and 10 feet from the outside of other pipe.



# CHAPTER 5 - WATER SYSTEMS

## Chapter 5 Water System

### 5.1. DESIGN AND CONSTRUCTION STANDARDS

#### 5.1.1 Design Report

- A. A design report prepared by a professional engineer licensed in the State of Montana which addresses fire and domestic flow requirements shall be submitted to and approved by the CoGF.
- B. The design and design report shall meet the minimum requirements of *MDEQ Circular 1*.
- C. The report shall include flow test results or modeled flow results, as approved by the CoGF, which show the static pressure and available flow from the hydrant at 20-psi residual pressure.
  - I. The CoGF will perform the required hydrant flow testing at no cost, if so requested (Utility Dispatch Clerk 406-727-8045).
  - II. City Engineering Staff will utilize the City's Water Model to provide a water system pump curve representative of the system's capacity at the point of connection if requested (406-771-1258).
- D. An overall plan of the development, *including all areas outside of the proposed development which would naturally be served through the proposed development shall be provided.*
- E. The Design Engineer shall calculate and provide the average day demand, the max day demand, and the required fire flow.
  - I. Refer to the current Water Facility Plan for existing system design data;
  - II. Provide demand calculations in units of gpd and ERUs; and
  - III. Provide velocity calculations in units of fps.

#### 5.1.2 General Construction Standards

- A. Water systems shall be constructed in accordance with the current edition of the Standards (this document), the current edition of the *MPWSS* for Water Distribution and other standards referenced elsewhere in this document. Any conflicts or differences in these documents shall be resolved in favor of the OCCGF, these Standards, and then the *MPWSS*.

#### 5.1.3 Offsets

- A. Water mains and appurtenances shall maintain horizontal and vertical offsets as required in *MDEQ Circular 1*.
- B. Water service lines and appurtenances shall maintain minimum horizontal separation of 10 feet and a minimum vertical separation of 18 inches from all sewer mains, and storm mains, and sewer service lines, as measured from the outside of the pipe.
- C. All underground electrical, gas, phone, fiber, and cable lines must be installed at least 10 feet horizontally and 18 inches vertically from water mains and at least 5 feet horizontally and 12 inches vertically from services.



## 5.2. WATER MAINS AND SERVICE LINES

### 5.2.1 Water Pipe

#### A. Size

- I. The main shall be sized to meet the demands of the proposed development and *areas outside of the proposed development which would naturally be served through the proposed development, or as directed by the City Engineer*;
- II. Refer to the CoGF *Extension of Services* for oversizing and reimbursement information;
- III. Minimum main size shall be 8-inch;
- IV. Fire hydrant leads shall be 6-inch;
- V. The Design Engineer shall refer to the current Water System Facility Plan and correspond with the City Engineering Office to determine if oversized mains are required for the development;
- VI. Capacity shall meet the max day plus fire flow and peak hour demand;
  - a. Required fire flow shall be determined by the Fire Code and verified by the CoGF Fire Department.
- VII. Velocity shall not exceed 15 feet per second through a public main line; and
- VIII. C value for flow calculations in PVC pipes shall be between 130 and 150.

#### B. Location

- I. Mains shall be extended to far property line of the development or such other point that may be specified by the City Engineer. Subdivisions and corner lot developments may be required to extend mains to property lines in multiple directions;
- II. Mains shall be under the paved section of the roadway, unless a deviation request is approved by the CoGF Engineering Division;
- III. Water mains are located 10 feet away from the road center line on the west side of streets and on the north side of avenues.
- IV. Transmission mains shall be located as approved by the City Engineer;
- V. Fire hydrant leads shall not exceed 50 feet in length;
- VI. Where mains or fire hydrant leads cannot be installed in the public ROW, a minimum 20-foot wide easement shall be provided with the line in the center of the easement. A wider easement may be required based on the bury depth of the main. Trees, lights, signs, retaining walls, and structures shall not be installed within the easement; and
- VII. Mains shall be buried a minimum of 6.5-feet. Less bury depth requires City Engineering Office approval and insulation. Plans shall note proposed insulation locations.

#### C. Material

- I. C-900 PVC pipe shall be manufactured within one year of the bid date, free of any scrapes or defects, have a constant color throughout the pipe at the time of installation, and be in new condition;
- II. 6-inch fire hydrant leads shall be PVC – DR14 gasket pipe conforming to AWWA C-900 Standards;
- III. 8-12 inch water mains shall be PVC – DR14 gasket pipe conforming to AWWA C-900 Standards;

- IV. 14-24 inch water mains shall be PVC – DR18 gasket pipe conforming to AWWA C-900 Standards;
  - V. Ductile Iron pipe can be required by the City Engineering Office in special conditions such as high working or surge pressures and when pipe is going to be buried in petroleum contaminated soils; and
  - VI. Water mains larger than 24-inch shall be Ductile Iron with a pressure class based on the working pressure of the main.
- D. Ductile Iron – Shall meet current MPWSS material and construction requirements
- I. Ductile Iron pipe shall have a minimum thickness class of 51 (a higher class may be required in some situations);
  - II. Only used as approved by the City Engineer;
  - III. Joints shall be push-on;
  - IV. Use nitrile gaskets with push-on and Mechanical Joint (MJ) connections for areas with hydrocarbon contamination; and
- E. Pipe joint gaskets:
- I. Push-on joints utilize a single gasket meeting AWWA C111;
  - II. Standard gasket shall be Styrene Butadiene Copolymer (SBR);
  - III. Special gaskets for use in areas of hydrocarbon contaminated soils and/or ground water shall be Acrylonitrile (Nitrile) Butadiene and Grafoil gaskets on flange fittings; and
  - IV. Design Engineer shall verify that the special gaskets are suitable, acceptable, and safe for use in the contaminated soils and/or ground water.

### 5.2.2 Valves

- A. Size and Type
- I. 12-inch diameter and smaller shall be gate valves; and
  - II. Larger than 12-inch diameter shall be butterfly valves.
- B. Location
- I. Shall be installed at each leg of every tee and cross and at each road intersection crossing. A valve is not required to be installed on the downhill/gradient side of the main on a tee leading to a fire hydrant;
  - II. Maximum spacing shall not exceed 500 feet unless otherwise approved by the City Engineer;
  - III. Shall not be located underneath curb and gutters, sidewalks, boulevards, travel route of a multiple use path, or within the wheel path of a vehicular travel lane; and
  - IV. A new valve shall be installed at all connections to existing water mains regardless of the proximity of an existing valve.
- C. Gate Valves shall be Mueller, Kennedy, Clow, or Waterous Gate Valves with:
- I. Minimum 250 psig working pressure meeting AWWA C509 and/or C515;
  - II. Resilient Seat;
  - III. Push-on joint;
  - IV. Valve to open counterclockwise;
  - V. 2-inch square operating nut;
  - VI. Fusion bonded epoxy exterior and interior coating; and
  - VII. Double wrap with polyethylene encasement in accordance with AWWA C105;

- D. Tapping valves shall be Mueller, Kennedy, Clow, or Waterous tapping valve with:
  - I. Resilient Seat;
  - II. 250 psig maximum working pressure;
  - III. 500 psig static test pressure;
  - IV. Tapping by mechanical joint;
  - V. Open counterclockwise;
  - VI. 2-inch square operating nut;
  - VII. Double wrap with polyethylene encasement in accordance with AWWA C105;
  - VIII. Minimum 10 mil fusion bonded epoxy exterior and interior coating; and
  - IX. Flanged end drilling complies with ANSI B16.1 class 125.
- E. Butterfly Valves shall be Mueller, M&H, Pratt, Kennedy, or Dezurik with:
  - I. Class 250;
  - II. Push-On joints or Mechanical Joint by Mechanical Joint;
  - III. Valve to open counterclockwise;
  - IV. Minimum 450 lbs torque rated operating stem and nut;
  - V. 2-inch square operating nut;
  - VI. Fusion bonded epoxy exterior and interior coating;
  - VII. Lubricated screw type operators designed for bury;
  - VIII. Side operator shall be located on south or east side of water main; and
  - IX. Double wrap with polyethylene encasement in accordance with AWWA C105.
- F. Auxiliary fire hydrant valves shall be Mueller, Kennedy, Clow, or Waterous 6-inch gate valves with:
  - I. 250 psig rated gate valve;
  - II. Resilient Seat;
  - III. Flanged joint by push-on joint; and
  - IV. Double wrap with polyethylene encasement in accordance with AWWA C105.
- G. Domestic water services and fire lines (4- and 6-inch) shall be Mueller, Kennedy, Clow, or Waterous gate valves with:
  - I. 250 psig rated gate valve;
  - II. Resilient Seat;
  - III. Flanged joint by push-on joint; and
  - IV. Double wrap with polyethylene encasement in accordance with AWWA C105.

### 5.2.3 Valve Boxes

- A. Shall be cast iron, 3 piece screw type, Heavy Duty;
- B. 5-1/4-inch diameter shaft;
- C. Lid with "Water" lettering;
- D. Shall be of sufficient length to be adjustable to finish grade;
- E. Use of "drop in" risers will not be allowed;
- F. Tyler model 6860 heavy duty series, East Jordan Iron Works 8560 series, or Star Pipe "heavy duty";
- G. Number 6 bases or as required for valve size; and
- H. Valve box shall have a protective bituminous asphaltic seal coating.
- I. If installed in public or private roadway lids shall be 1/4" to 3/8" below finished grade.

#### 5.2.4 Fire Hydrants

##### A. Location

- I. Placement is subject to the approval of the Fire Chief and City Engineering Office;
  - II. Spacing shall not exceed 500 feet in residential areas;
  - III. Spacing of fire hydrants in commercial and industrial areas shall not exceed the distances stated in the International Fire Code while meeting the requirements of the Montana Department of Environmental Quality;
  - IV. Provide a 3-foot separation from the center of the fire hydrant to the back of curb and/or from the edge of sidewalk; and
  - V. Provide bollards for hydrants unprotected by curb.
- B. Shall be Mueller Super Centurion 250 model A-423, Kennedy Guardian model K81A, or Waterous Pacer model WB67-250;
- C. Furnish Fire Hydrants meeting ANSI/AWWA C502 standards, with a 250 psig standard maximum working pressure;
- D. Shall include a 5-1/4 inch main valve opening;
- E. 6 inch shoe with push-on joint;
- F. One 4 inch pumper nozzle with NST #40484 gage and two 2-1/2 inch hose nozzles ASA specification B26 for National Standard Fire Hose Coupling Screw Threads (7.5 threads per inch);
- G. Furnish "Compression" type hydrants with safety or traffic flange and safety stem coupling with above ground line;
- H. Hydrants shall be of the dry top design with 2 or more "O" rings sealing the water from the operating mechanism;
- I. The operating mechanism shall be automatically lubricated from a sealed, self-contained lubricating reservoir;
- J. Hydrants shall be painted with "Mueller Yellow" Amercoat 370 fast-dry multipurpose epoxy or Polane SP polyurethane enamel;
- K. Furnish fire hydrants of sufficient length such that the bury line is at the finished grade; and
- L. Double wrap with polyethylene encasement in accordance with AWWA C105.

#### 5.2.5 Fittings

- A. Utilize ductile iron (AWWA C153 pressure rating 350 psig) or cast iron (AWWA C110 pressure rating 250 psig) fittings per the following:
- I. Cement Mortar (AWWA C104) or fusion bonded epoxy (AWWA C550) interior lined, double thickness meeting the ANSI/AWWA C104/A21.4 requirements;
  - II. Approximately 1 mil thick asphaltic seal coating (ANSI/AWWA C153/A21.53) or fusion bonded epoxy coated;
  - III. Push-on joints (Use other joints where necessary for restraint or other special conditions);
  - IV. All AWWA C110 or C153 compact push-on (union-tite) water main fittings shall be supplied with restraint ears.
  - V. Install ductile iron push-on by flange fittings for fire hydrants and service lines 4-inches and larger constructed on new mains or approved tapping sleeve for connections to existing mains; and

VI. All fittings must be manufactured in accordance with NSF61.

#### 5.2.6 Couplings

- A. Pipe couplings shall meet one of the following:
  - I. Cast type with cast iron or ductile iron sleeves malleable or ductile iron flanges, shall be “long body”; or
  - II. Gray iron or ductile iron, mechanical joint solid sleeves, shall be “long sleeves” such as Tyler Union C153 ductile iron “Long” solid sleeve; Romac Style “501” Long Barrel Coupling; Smith-Blair 442 Long sleeve coupling; Romac Alpha restraint coupling, or equal.
- B. Couplers shall be fusion bonded epoxy coated; and
- C. MEGALUG restraints, or approved equal, shall be used with mechanical joint sleeves.

#### 5.2.7 Tapping Sleeves

- A. Utilize full circumference tapping sleeve with NPT stainless steel test plug and stainless steel, cast iron, or ductile iron body. Supply stainless, cast, or ductile iron mechanical joint type sleeve with end and side gaskets;
- B. Tapping sleeve outlet joint shall be flanged;
- C. Outlet flange dimensions and drilling shall comply with ANSI B16.1 Class 125;
- D. The flange shall be ductile iron or carbon steel complying with fusion bonded epoxy coating for stainless steel sleeves;
- E. The working pressure for 4 inch through 12 inch shall be a minimum of 200 psig and minimum of 150 psig for 14 inch and larger;
- F. Fusion bonded epoxy coating inside and outside;
- G. Double wrap with polyethylene per below requirements;
- H. Utilize gaskets per requirements outlined in the gasket Section 5.1.2.E above; and
- I. Pressure test at a minimum of 100 psig for 10 minutes or as recommend by manufacturer.

#### 5.2.8 Polyethylene Wrapping

- A. PVC Main:
  - I. Double wrap all ductile or cast iron *pipe fittings, valves, and hydrants* with polyethylene encasement in accordance with AWWA C105;
  - II. The inner layer shall be 8 mil and outer layer shall be 8 mil of the polyethylene wrap for a total of 16 mil;
  - III. At no time shall a “sling” or “strap” come into contact with the polyethylene; and
  - IV. Polyethylene adhesive tape shall be used for all repairs to the wrap.
- B. Ductile/Cast Iron Pipe:
  - I. Double wrap all ductile or cast iron pipe and pipe fittings, valves, and hydrants with polyethylene encasement;
  - II. The inner (1<sup>st</sup>) layer of polyethylene wrap will be V-BIO which consists of three layers of co-extruded linear low density polyethylene (LLDPE);
  - III. The outer (2<sup>nd</sup>) layer of polyethylene wrap will be 4 mil cross laminated high density polyethylene;
  - IV. At no time shall a “sling” or “strap” come into contact with the polyethylene; and
  - V. Polyethylene adhesive tape shall be used for all repairs to the wrap.

### 5.2.9 Wax Tape System

- A. The entire flange and all bolts on mechanical and flanged joints, restraints, sleeves, couplers, fittings, and valves shall be wrapped with a wax-system;
- B. The wax tape system (such as provided by Trenton Corporation or approved equal) utilized for below ground applications consists of three separate parts:
  - I. Primer;
  - II. Wax Tape #1; and
  - III. Poly ply outer tape.
- C. The wax tape system does not replace the polyethylene wrapping requirement.

### 5.2.10 Location of Test Taps

- A. A test tap shall be located within 5 feet of the beginning and end of the main;
- B. Within 5 feet of the “source water”; and
- C. Test taps shall be located with a maximum spacing of 400 feet along the main.

### 5.2.11 Water Services

#### A. General

- I. Service pipes shall be so arranged that each separate building and/or house shall be supplied by a separate service line from the City main;
- II. Structures containing two or more residences under separate ownership shall have separate service lines from the main, service valves, and meters for each residence;
- III. Structures containing two or more residences, offices, or businesses that are rental units under common ownership shall have one service line, valve, and meter for all occupants within a single structure;
- IV. Each water meter shall be controlled by an independent valve or curb stop;
- V. A valve or curb stop (with box) shall be installed in each service line so that the supply may be controlled from the street side of the property line;
- VI. The curb valve shall be perpendicular to the main and located in the public right-of-way or a city easement;
- VII. It is unlawful to extend a water service which is intended to supply water to a property facing one avenue or street to another property facing another avenue or street, if the water service has to cross a public right-of-way such as an avenue, street, or alley;
- VIII. When a lot or parcel is developed to a permitted use, all duplicate, excess, and/or unused water services and fire services, including stub-outs, shall be disconnected from the main and plugged at the main;
- IX. Construction on parcels aggregated will trigger abandonment of unused water and fire services at the main, this shall occur within six months;
- X. Water service lines supplying water to a building or buildings that are to be razed shall be plugged at the City water main;
  - a. Unless the service has adequate bury depth, is copper, and will be put back into service in the near future; then
  - b. The service shall be physically disconnected from the building side of the controlling curb stop and the curb box shall be reset over the curb stop.

- XI. New or reconstructed services shall meet current Standards, including location of curb stops and meter pits; and
  - XII. Domestic water services shall not be tapped on a fire service line or fire hydrant main.
- B. Construction of Water Service
- I. A fee shall be issued when it is necessary to tap an existing or new water main for a service connection or a test tap:
    - a. The permittee/contractor shall pay by direct billing for all test taps, testing equipment, overtime, and chemicals used;
    - b. When the project includes five (5) or less taps, the City will provide the equipment, labor, and materials required to tap the main for water service lines that are ¾-inch up to 2-inches in diameter (this includes the corporation stop, curb stop, and box);
    - c. Saddles, clamps, and other extraneous fittings are not included in this fee and will be billed extra by the CoGF Finance Department;
    - d. When the project includes six (6) or more taps, the contractor shall provide the corporation stop, curb stop, and box;
      - 1. All excavation shall be ready for tapping crews at the same time;
      - 2. The maximum distance between taps shall be 1,000 feet; and
      - 3. Lost crew time due to unsafe or incomplete excavations shall be billed directly to the permittee/contractor in addition to the tapping fee.
    - e. The Contractor will excavate around the main and prepare a safe trench, meeting the minimum OSHA requirements, from the main to the approved curb stop location; and
    - f. Water service lines 4-inches and larger in diameter shall connect to the water main with a tee and gate valve.
  - II. The Contractor is responsible for utilizing a Licensed Plumber to install the service line (2-inches and smaller) from the main to the curb stop valve and the Contractor is responsible for installing the curb stop and box;
  - III. The Contractor is responsible for the installation of the backfill and complete site restoration per the requirements outlined throughout this document;
  - IV. City personnel shall inspect the tap and service line **prior to backfill**;
    - a. PWD Staff shall inspect irrigation service lines, domestic water service lines, and fire lines that are 4-inches and larger; and
    - b. PCD Staff shall inspect irrigation service lines, domestic water service lines, and fire lines that are 2-inches and smaller.
  - V. Satisfactory pressure leakage and bacteriological tests on 4-inch and larger lines shall be conducted in accordance with City policy, these standard specifications, and the current edition of the MPWSS;
  - VI. On existing roads, the City will restore the pavement surface unless the Contractor is authorized by the Street Division to restore the pavement surface. This is because, periodically, additional pavement surface restoration, beyond that which is needed to make the service connection is required;
    - a. The City will charge the Contractor for equipment, labor, and materials required to complete the work. The Contractor will not be charged for

any of the additional pavement restoration that the City chooses to complete;

- VII. Per the locally adopted Plumbing Code, the Owner will be responsible to hire a Licensed Plumber to construct the service line from the curb stop to the point of service; and
- VIII. Sand bedding is required on copper service line.

C. Location

- I. Services shall connect to and extend from the main perpendicularly;
- II. Services shall connect to the main on the front door side of the structure if multiple mains are available;
- III. Services shall be buried a minimum of 6.5-feet below the final street grade and the finished grade of the consumer's premises; and
- IV. Less bury depth requires PCD Staff approval and insulation.
- V. All water service lines shall be installed at least 10 feet from trees.

D. Size

- I. The water service tap, corporation stop, service line, curb stop, and meter shall all be the same nominal size from the main to the meter;
- II. Acceptable water service and fire line sizes are as follows:
  - a. ¾-inch service;
  - b. 1-inch service;
  - c. 1.5-inch service;
  - d. 2-inch service;
  - e. 4-inch service;
  - f. 6-inch service;
  - g. 8-inch service; and
  - h. Obtain approval from City Engineering office for service lines larger than 8-inches.
- III. If a service line size is reduced prior to the meter pit or vault, the design engineer shall provide hydraulic data indicating maximum achievable flow rates at the meter are within the manufacturer's recommendations and obtain written authorization from the City Engineer.

E. Materials

- I. 2-inch and smaller services shall be type K soft copper from main to structure entrance valve;
  - a. See below for service lines over 100 feet in length; and
  - b. Pipe joint is flared end to entrance valve.
- II. From the entrance valve to a point a minimum on one (1) foot past the meter setting, the service material shall be of Type M or L hard copper pipe;
- III. Water service lines longer than 100 feet in length;
  - a. From the meter pit to the structure shall be Type K soft copper or HDPE, 200 psig meeting AWWA C-901 standards;
  - b. When 200 psig HDPE piping is used a meter pit approved by the City Engineer shall be installed 2 feet from the curb stop on the property side of the curb stop at the property owner's expense;
  - c. Type K soft copper shall connect the main to the meter pit;



- d. Fittings used to connect the copper pipe to the 200 psig HDPE pipe shall be all brass similar to Mueller “Insta Tight” fittings; and
  - e. When 200 psig HDPE pipe is used, #14 high strength copper tracer wire shall be installed from the curb stop to the house in the trench with the service line.
- IV. 4-inch and larger fire lines and services shall be PVC AWWA C-900 DR-14 or Ductile Iron Pipe.
- a. Ductile iron pipe is required from 10 feet outside the foundation to the entrance valve inside the building and in areas of bury in petroleum contaminated soils;
  - b. Cast iron is acceptable from the main to a point 10 feet outside the building only when the existing service is cast iron;
  - c. Double wrap all ductile or cast iron pipe and pipe fittings with Polyethylene Encasement in accordance with AWWA C105;
  - d. Pipe joints shall be push-on with single gasket meeting AWWA C111;
  - e. Utilize flange joint to gate valve connected to main; and
  - f. Utilize flange and/or mechanical joints where necessary.
- V. Unsuitable materials – an existing galvanized or lead service line that is being repaired shall be replaced with an acceptable type material from the main to the structure.

#### 5.2.12 Service Clamps (Saddles)

- A. For 12-inch and smaller C900 PVC saddles shall be Muller H-13000 series, A.Y. McDonald 3805 series, or Ford S902 (Style B 2-piece bolted design);
- B. For ductile iron or C900 PVC larger than 12-inches saddles shall be Muller BR2S or BR2W series or equal approved by the PWD;
- C. Supply two-piece water service saddles with AWWA taper (C.C.) thread to match corporation stop or component identified on the Construction Drawings; and
- D. Tighten and torque saddle bolts and straps with breakaway type torque wrench per manufacturer’s recommendations.

#### 5.2.13 Corporation Stop

- A. Shall be Mueller B-25000, Ford FB600 Ballcorp, or AY McDonald 4701B with
  - I. Ball valves;
  - II. Bronze components;
  - III. 300 psig maximum working pressure;
  - IV. 90-degree turn;
  - V. AWWA taper inlet thread; and
  - VI. Copper flare straight outlet connection.

#### 5.2.14 Curb Stop Valves

- A. Shall be Mueller B-25204N or Ford B22M with:
  - I. Ball valve;
  - II. Bronze plug;
  - III. Copper flare nut on both ends;
  - IV. Large tee head key;

- V. The Minneapolis pattern valve is not required;
- VI. 90-degree turn;
- VII. 300 psig maximum working pressure; and
- VIII. Include a 10-inch x 10-inch x 2-inch concrete support block under curb stop.

#### 5.2.15 Curb Boxes

- A. Shall be Tyler 6500, A.Y. McDonald 5700, or Star Pipe Product SB series with:
  - I. Adjustable screw type;
  - II. Bolt down lid with brass bolt and “Water” lettering;
  - III. Standard curb boxes shall be a minimum of 6.5-feet to 7-foot extended length;
  - IV. Screw extensions as need to reach finish grade;
  - V. Tyler LP-5041, 6500, or Star Pipe SB series enlarged bases for 1.5-inch and 2-inch curb stops;
  - VI. Arch style enlarged base; and
  - VII. Curb boxes shall be “heavy duty” with protective bituminous asphaltic seal coating.

#### 5.2.16 Entrance Valve and Backflow Assembly

- A. The entrance valve shall be located within 2 feet of the point where the service enters the building and from 1 to 3 feet above the floor;
- B. An approved valve of good quality and good hydraulic characteristics must be placed so that the water can be readily shut off from the building;
- C. Full way gate valves or rotary valves, which include ball, cone and plug types are recommended;
- D. Better quality compression stops or globe valves are permissible;
- E. The inlet side of any entrance valve shall be mechanically joined to copper service lines ¾ inch through 2 inch by means of copper flare connections; and
- F. The inlet side of any entrance valve on service lines 4 inches and larger in diameter shall be mechanically joined to the service pipe and properly supported and restrained against movement in accordance with PWD specifications.
- G. All irrigation service lines, commercial water service lines, and commercial fire service lines shall be equipped with an approved backflow prevention assembly in accordance with the latest version of the Uniform Plumbing Code adopted by the City of Great Falls and shall meet the following criteria;
  - I. Backflow assemblies shall be tested yearly by an ASSE 5000 certified tester;
  - II. Backflow assembly certifiers shall be licensed per city licensing rules;
  - III. The property owner shall maintain backflow test reports (required 3 year minimum on file), and such reports shall be available upon request to the authority having jurisdiction; and
  - IV. Floor drains or floor sinks (with trap primers) may be required when the backflow is installed within a building.

#### 5.2.17 Tapping Saddles

- A. Ductile Iron
  - I. Mueller BR 2 B; or
  - II. Approved equal.

- B. PVC Pipe
  - I. Mueller H-13000 Series;
  - II. AY McDonald 3805;
  - III. Ford S902 Style B; or
  - IV. Approved equal.
- C. Bronze or brass alloy with 200 psig minimum work pressure;
- D. AWWA taper thread outlet
- E. Shall be Romac SST III or an equal approved by the PWD for service lines or main extensions larger than 4-inch; and
- F. Bolts for flange connection on tapping sleeves shall be Cor-Ten or Cor-Blue.

#### 5.2.18 Couplings

- A. Shall be three part union;
- B. Copper flare both ends; and
- C. Mueller H-15400, or approved equal.

#### 5.2.19 Mechanical Joint Restraints

- A. Shall be Megalug or approved equal.

#### 5.2.20 Pipe Bedding

- A. Shall be placed in accordance with CoGF detail 5-31;
- B. Shall be haunched under pipe with shovel;
- C. Type 1 bedding shall conform to MPWSS Section 02235 CRUSHED BASE COURSE  $\frac{3}{4}$  inch Minus;
- D. In the event ground water prohibits the use of  $\frac{3}{4}$  inch minus base course,  $\frac{3}{4}$  inch minus washed round rock aggregate may be used, with the Engineers approval, under the following conditions;
  - a. Filter fabric shall be laid on the excavated ditch bottom and encase the bedding and pipe;
  - b. The open graded aggregate shall be free draining and non-plastic;
  - c. The open graded aggregate shall conform to all applicable portions of MPWSS Section 02221, Type 1 Pipe Bedding, and shall generally be  $\frac{3}{4}$ " minus washed round rock (non-crushed or non-fractured) meeting the gradation requirements as specified below:
    - Passing the 1" Sieve - 100% by weight
    - Passing the  $\frac{3}{4}$ " Sieve – 90-100% by weight
    - Passing the #4 Sieve – 0-10% by weight
  - d. Trench plugs, as defined by CoGF detail 5-34, shall be installed once every 100 feet;
- E. Place Type 1 Pipe Bedding from 4 inches below the bottom of the pipe, around the pipe, and up to 6 inches over the pipe;
- F. The use of roller buckets and/or vibratory plates, attached to an excavator, for compaction within a public utility trench is not allowed;
- G. The use of "Recycled Asphalt" as bedding, backfill, or base course is not allowed;
- H. The use of "Recycled Concrete" as bedding or as a substitute for washed gravel is not allowed;

- I. The use of “Recycled Concrete” as backfill is only allowed when blended with other materials and only when approved by the City Engineer’s Office;
- J. The use of Concrete Washout as bedding and/or backfill is only allowed when approved by the City Engineer’s Office; and
- K. Pipe bedding for all Polyethylene wrapped pipes shall consist of a clean sand meeting the following requirements:
  - a. 100% passing the ¼-inch Sieve, 10 – 40% passing the No. 8 Sieve, and 0 – 10% passing the No. 16 Sieve;
  - b. The liquid limit for the material passing the No. 40 Sieve is a maximum of 25; and
  - c. The plasticity index shall not exceed 0.

#### 5.2.21 Warning Tape

- A. Shall be installed above all water mains and fire hydrant lines;
- B. Shall be a minimum of 5 mils thick;
- C. Shall be 3 inches wide;
- D. Shall conform to APWA colors; and
- E. Shall be buried 12 to 24 inches below the final grade.

#### 5.2.22 Tracer Wire

- A. Tracer wire is required on water mains that deflect horizontally between valves and/or run through easements within improved or unimproved areas; mains which do not deflect horizontally between valves and are located in a public right of way do not require tracer wire. Shall be #12 AWG fully annealed, high strength solid copper clad steel conductor
- B. 30-mil high-density HDPE or HMWPE insulation, rated for direct bury use at 30 volts;
- C. Shall be approved for direct bury;
- D. Conductor must be at 21% conductivity for locate purposes and have a minimum break load of 450 pounds;
- E. Insulation is to meet APWA/ULCC color code requirements for identification of the buried utility;
- F. Shall be taped every 5 feet to the top of the water main;
- G. Connectors should be capable of handling 2 to 4 wires per connector and designated as “water-proof”, such as snake bite locking connectors by Copperhead Industries, LLC;
- H. Connectors shall be dielectric silicon filled to seal out moisture and corrosion and installed in a manner so as to prevent any un-insulated wire exposure;
- I. Shall be spliced with moisture displacement connectors;
- J. Non-locking friction fit, twist on or taped connectors are prohibited;
- K. Grounding Anode shall be 1.3-inch D x 18.5-inch L magnesium drive in anodes weighing a minimum of 1.5 pounds;
- L. All anodes will include a HDPE cap with 20-feet of factory installed #12 AWG tracer wire with 30 mil high density HDPE insulation meeting the above requirements;
- M. Anodes shall be manufactured approved for direct bury and if required shall be placed at both the beginning and end of main that segments require tracer wire;
- N. Cobra T3, with optional shorting jumper, 1 inch conduit, above ground access box with hydrant flange adapter, as manufactured by Copperhead Industrial, LLC or approved equal;

- O. Grade level/in-ground access boxes may be installed if approved by the City Engineering Office;
- P. The access box shall have an encapsulated magnet, corrosion resistant isolated brass wire lugs, and opened with a standard pentagon head key wrench;
- Q. Access boxes shall have a switchable lid in order to isolate the ground if necessary;
- R. Access boxes shall meet APWA/ULCC color code requirements;
- S. Sufficient wire/slack (2-feet) shall be left in the access box allowing the cover to be lifted intact and allowing for future vertical adjustments; and
- T. Shall be made accessible in accordance with COGF detail 5-38.

#### 5.2.23 Marker Posts

- A. Shall be used when a main is located outside a paved surface;
- B. Shall be fiber glass (FlexPost®) and a minimum of 5-feet tall, minimum of 3.5-inches wide and include the CoGF PW Utility Division contact information.
- C. Shall conform to APWA colors;
- D. Shall be installed at bends, tees, and crosses; and
- E. Shall be installed at every valve or valve cluster and change in direction;



# CHAPTER 6 - SANITARY SEWER SYSTEMS

## Chapter 6 Sanitary Sewer System

### 6.1. DESIGN AND CONSTRUCTION STANDARDS

#### 6.1.1 Design Report

- A. A design report prepared by a PE licensed in the State of Montana which addresses sewer flows at full build-out of the development shall be submitted to and approved by the CoGF. The design report shall include an overall plan of development including all areas outside of the study area which would naturally be serviced through the study area.
- B. The design and design report shall meet the minimum requirements of *MDEQ Circular 2*.
- C. Average daily flows, peak hour flow criteria, wastewater flow rates by zoning areas, peaking factors, and other applicable design criteria shall be used as defined in the current *Sanitary Sewer Facility Plan*.
- D. Sewer mains shall be sized for the ultimate development of the tributary area. Nothing shall preclude the City from requiring the installation of a larger sized main if the City determines a larger size is needed to meet the requirements for future service. Joint participation by the City may be applicable where over sizing is deemed appropriate by the City Engineer. The minimum diameter of any gravity sanitary sewer main shall be eight (8) inches.
- E. List all improvements or proposed additions to the sanitary sewer system.
- F. Assess the ability of the existing collection system to handle the peak design flow from the project and the impact of the Wastewater Treatment Plant.
- G. For existing or proposed lift stations, provide the following:
  - I. A description of the existing and/or proposed wet well, pumping system, and force main;
  - II. The capacity of the existing and/or proposed lift station service area;
  - III. A map showing the existing and/or proposed lift station service area;
  - IV. A list of the existing users and their average design flows;
  - V. The existing and/or proposed peak design flow and reserve capacity;
  - VI. For lift stations to be owned and maintained by the CoGF, the minimum force main pipe size leaving the lift station shall be 4-inches in diameter;
  - VII. The pump run and cycle times for the existing and/or proposed average and peak design flows;
  - VIII. The hydraulic capacity of the existing and/or proposed force main(s);
  - IX. A list of the proposed users and their average design flows;
  - X. The proposed average and peak design flows to the lift station;
  - XI. The reserve capacity of the lift station with the proposed project at full capacity;
  - XII. The pump run and cycle times for the proposed average and peak design flows; and
  - XIII. Recommendations for improvements to an existing lift station, if necessary, to enable the lift station to serve the proposed project.

#### 6.1.2 General Construction Standards

- A. Sewer systems shall be constructed in accordance with the current edition of the Standards (this document), the current edition of the *MPWSS*, as modified by the CoGF *Special Provisions* for Sanitary Sewer Collection Systems, the CoGF Municipal Code, and other standards referenced elsewhere in this document. Any conflicts or differences in these



documents shall be resolved in favor of the OCCGF, these Standards, and then the MPWSS.

#### 6.1.3 System Usage Restriction & Industrial Pretreatment

- A. Usage shall be in accordance with CoGF Municipal Code Title 13 or its subsequent amending or replacement title/ordinance(s);
- B. Adhere to the City's Pretreatment and Surcharge requirements (*CoGF Municipal Code Title 13*);
- C. No storm water shall discharge to any sanitary sewer unless approved by both the City Engineer and the Environmental Division Supervisor;
- D. Pretreatment Facilities – An industrial user shall provide necessary wastewater treatment as required to comply with Title 13 (or its subsequent amending or replacement title/ordinances(s)). Detailed plans showing the pretreatment facilities and operating procedures shall be submitted to the Director for review and shall be acceptable to the City before construction of the facility. The review of such plans and operating procedures will in no way relieve the industrial user from the responsibility of modifying the facility as necessary to produce an effluent acceptable to the City under the provisions of Title 13;
- E. Pretreatment Flow Equalization – An industrial user shall install and maintain necessary storage and flow control to achieve compliance with flow restrictions imposed by the City under CoGF Municipal Code Title 13; and
- F. Monitoring Facilities – An industrial user shall install effluent monitoring facilities as required to comply with CoGF Municipal Code Title 13. Monitoring equipment shall be located and maintained on the industrial user's premises in a location outside of production areas and constructed such that City Staff may access the monitoring facilities unannounced to collect representative samples of the effluent. Monitoring facility shall be located such that samples collected are representative of the volume and nature of the industrial effluent that has not been diluted with regular sanitary waste or other unregulated flows;

#### 6.1.4 Sulfide Generation Analysis

- A. The City Engineer or the Environmental Division Supervisor may require a sulfide generation analysis; and
- B. Pretreatment, non-corrosive linings, and special lift station design are required when dissolved sulfide is likely to exceed 0.2 mg/l or H<sub>2</sub>S gas concentrations are expected to exceed 20 ppm within the sanitary sewer atmosphere.

#### 6.1.5 Location

- A. In a development that includes alleys, a sanitary sewer gravity main shall be horizontally located in the center of the alley.
- B. In a development without alleys, a sanitary sewer gravity main shall be horizontally located within the paved portion of the road and 10 feet away from the road center line. The main shall be located on the east side of a street and on the south side of an avenue.
  - I. Water mains are located 10 feet away from the road center line on the west side of streets and on the north side of avenues.

- II. Storm mains are generally located near the center of the road and shall be located a minimum of 10 feet (outside of pipe/structure to outside of pipe/structure) away from the water main.
- C. Sanitary sewer force mains and interceptor mains shall be located as approved by the City Engineer.
- D. Where mains cannot be installed in the public ROW, a minimum 20-foot wide easement shall be provided with the main in the center of the easement. A wider easement may be required based on the bury depth of the main.
- E. Sewer mains and manholes located in an easement shall be designed and constructed so that all such facilities are readily accessible for maintenance and repair. The design shall allow for a City Vac-Truck to drive over the manhole without requiring the vehicle to backup. A minimum 55-foot by 55-foot area is required for a Vac-Truck to turn around.
- F. The minimum bury depth of a gravity sanitary sewer main shall be sufficient to prevent freezing and shall have a minimum of four (4) feet of cover as measured from the top of the pipe.
- G. The minimum bury depth of a sanitary sewer force main shall be sufficient to prevent freezing and shall have a minimum of 6.5-feet of cover as measured from the top of the pipe.
- H. The minimum bury depth of a gravity sanitary sewer service line shall be sufficient to prevent freezing and shall have a minimum of four (4) feet of cover as measured from the top of the pipe. The recommended minimum bury depth is six (6) feet as measured from the top of the pipe. Sufficient insulation shall be installed to protect the service line from freezing when the bury depth is less than six (6) feet. Open trench replacement of existing sanitary sewer service lines shall also meet the recommended minimum bury depths or provide sufficient insulation to protect the service line from freezing. Trenchless replacement methods, such as cured in place lining or pipe bursting, do not require additional insulation.
- I. Sewer valves and manhole covers shall not be located in curb and gutters, sidewalks, boulevards, or within the wheel path of vehicular travel lane.
- J. Where possible, there should be a least 10 feet of edge to edge horizontal separation between storm mains and sewer mains.

#### 6.1.6 Offsets

- A. Sewer mains and appurtenances shall maintain horizontal and vertical offsets as required in [MDEQ Circular 2](#).
- B. Sewer service lines and appurtenances shall maintain minimum horizontal separation of 10 feet and a minimum vertical separation of 18 inches from all water mains and water service lines, as measured from the outside of the pipe.
- C. All underground electrical, gas, phone, fiber, and cable lines must be installed at least 10 feet horizontally and 18 inches vertically from sewer mains and at least 5 feet horizontally and 12 inches vertically from services.

## 6.2 SEWER MAINS AND SERVICE LINES

### 6.2.1 Gravity Sewer Mains

- A. Design capacities of sewer mains shall be based on Table 1 as shown below. The effects of the proposed development’s sewer loading on downstream sewer lines shall be analyzed and included in the design report.
- B. The minimum main diameter shall be 8 inches.
- C. Upsizing of mains will not be approved for utilization of minimum slopes to meet elevation restraints.
- D. The minimum bury depth of a gravity sewer main is 4.0 feet as measured from the top of the pipe. Less bury depth is allowed in special cases when sufficient insulation is provided to protect the line from freezing.
- E. Velocity:
  - I. Minimum velocity of 2.5 fps, based on a flowing full condition; and
  - II. Maximum velocity of 15 fps, unless approved by the City Engineer.

**Table 1 - Sewer Flow Depths**

Diameter of Sewer Main (inches)	Depth of Flow / Diameter (%)
≤ 10	70
> 10 – 15	73
> 15 – 18	75
> 21 – 27	77
> 27	80

- F. Pipe 8 – 15 inches in diameter shall be PVC ASTM D 3034, SDR 35 and/or SDR 26 PVC with Styrene Butadiene Copolymer gasketed joints and fittings.
- G. Pipe larger than 15 inches in diameter shall be PVC ASTM F 679, SDR 35/PS46 and/or SDR 26/PS115 with Styrene Butadiene Copolymer (SBR) gasketed joints and fittings.
- H. In areas with hydrocarbon contamination Acrylonitrile Butadiene (NBR) pipe joint gaskets shall be utilized.
- I. Main to main connections shall be made with PVC gasketed coupling or stainless steel sleeved flexible coupling with flowable fill encasing the connection.
- J. Double wrap all ductile or cast iron pipe and pipe fittings, located underground, with polyethylene encasement in accordance with the following:
  - I. The inner layer of polyethylene wrap shall be V-Bio which shall consist of three layers of co-extruded linear low density polyethylene (LLDPE);
  - II. The outside layer of polyethylene wrap shall be 4 Mil Cross Laminated High Density Polyethylene;
  - III. At no time will “slings” or “straps” come into contact with the polyethylene; and
  - IV. Polyethylene adhesive tape shall be used for all repairs to the wrap.
- K. Utilize a wax tape system designed for below ground applications (that consists of three separate parts, a primer, wax tape #1, and an outer wrap, such as supplied by Trenton Corporation) on metal components including, but not limited to, the entire flange, all bolts on mechanical and flanged joints, restraints, sleeves, couplers, and valves; and

- L. Prior to the City's acceptance of the sewer system the Contractor must provide television inspection of the system. The cost of television inspection will be the responsibility of the Contractor. If any deficiencies are found during the inspection, the Contractor shall correct them at the Contractor's expense.

#### 6.2.2 Sewer Force Mains

- A. Design shall be as required per *MDEQ Circular 2*, except as specified below:
  - I. CoGF owned and maintained sewer force mains shall be sized as required to provide a minimum cleaning velocity of 2.5 fps (the minimum size is 4-inches); and
  - II. Sewer force mains shall terminate at a manhole.
- B. Sewer force mains shall be (at a minimum) PVC pressure pipe, ASTM 2241, class 200 SDR 21 or stronger pipe.
- C. Sewer force mains pipe type shall meet or exceed 1.5 times the manufacturer's recommended maximum pressure.
- D. The minimum bury depth of a sewer force main is 6.5 feet as measured from the top of the pipe. Less bury depth is allowed in special cases when insulation is provided and the Design Engineer provides heat flow calculations showing that the pipe will not freeze.
- E. Service taps shall not be allowed on CoGF force mains.
- F. Private force mains shall be connected to the sewer collection system at a manhole as shown in Detail 5-55;
  - I. A manhole with a force main or force service connection shall be coated to protect the structure from deteriorating.
- G. Tracer Wire shall meet the same requirements as for water main, except:
  - I. Force mains burst through existing mains or installed without continuous trench access shall be installed with ¼-inch steel tracer cable.
- H. Coordinate with the City Engineer's Office when designing and constructing private sewer force mains and pumps.

#### 6.2.3 Sewer Services

- A. General
  - I. One sewer service per structure, that receives potable water, is required;
  - II. The number of separate sewer service lines (connections at the main) shall not exceed the number of buildings with different addresses on the lot;
  - III. Buildings without addresses shall not have an independent sewer service line connected to the main;
  - IV. Deviations from these rules shall be handled on a case by case occurrence and only when deemed physically impossible and only as approved by the City Engineer; and
  - V. Connection fees shall apply for each sewer service connection.
  - VI. All sewer services shall be installed at least 10 feet from trees.
- B. Where a building is to be razed (OCCGF Title 13):
  - I. The sewer service shall be severed at the property line;
  - II. If the sewer service is not going to be used for the foreseeable future, the service shall be abandoned at the public sewer main;
  - III. The public sewer main shall be properly plugged; and

- IV. A PW City Inspector shall inspect the work.
- C. Construction of Sewer or Storm Service:
  - I. When it is necessary to tap an existing or new sewer main for a service connection:
    - a. An in-line wye shall be installed on new sewer mains for sewer services;
    - b. Connection of sewer services to an existing main shall utilize service saddles clamped or strapped using stainless steel bands and an Inserta Tee as approved by the PWD. The Contractor will provide the equipment, labor, and materials required to tap the main via an Inserta Tee or approved equal;
    - c. The tap shall be made by a licensed drain layer and the drain layer shall be responsible for damages to the City main as a result of their own negligence;
    - d. The Contractor is responsible for installing the service line from the main to the property line; and
    - e. If the existing service line connection is damaged the contractor shall obtain approval from the PWD before tapping a new connection into the City sewer main. The Contractor shall repair or replace the damaged fitting as directed by the PWD.
  - II. Trenches within the streets or alleys shall be compacted to meet 95% of maximum dry density as determined by AASHTO, T-99 specifications;
  - III. Trenches in lawns and non-driven areas shall be compacted to meet 85% of the same specification;
  - IV. All work shall be warranted by the drain layer for 1 year against defects in materials and 2 years for defects in workmanship;
  - V. The Contractor is responsible for restoration of the public right of way to the pre-construction condition meeting minimum City Standards;
  - VI. PWD personnel shall inspect the tap and service line **prior to backfill**;
  - VII. On existing roads, the City will restore the pavement surface unless the Contractor is authorized by the Street Division to restore the pavement surface. This is because, periodically, additional pavement surface restoration, beyond that which is needed to make the service connection is required;
    - a. The City will charge the Contractor for equipment, labor, and materials required to complete the surface restoration work associated with the service connection. The Contractor will not be charged for any of the additional pavement restoration that the City chooses to complete;
  - VIII. The Owner will be responsible to construct the service line from the property line to the point of service;
  - IX. Sewer service lines 8-inches and larger in diameter shall connect to the sewer main at a manhole;
  - X. Sewer service lines 4-inches and 6-inches in diameter shall tap the upper quadrant of the sewer main; and
  - XI. Storm service lines of any size have the option of connecting to the storm main at a manhole.
- D. A new sewer service shall be installed with a minimum grade of 2%;
- E. New sewer service lines on newly constructed public sewer mains shall be air tested;

- F. Pipe bursting and cured in place lining of existing sewer service lines:
- I. An existing service line that is less than the minimum grade (but not negative grade) can be burst or lined at the existing grade;
  - II. A video inspection shall be performed before and after the bursting or lining process. The City shall be present to witness video inspections. Prior to bursting or lining the existing host pipe, the existing line shall be free of any obstacles that would cause an unfavorable grade in the new liner;
  - III. Negative grade and obstructions shall be removed and repaired prior to bursting or lining;
  - IV. Sewer service pipe material used for pipe bursting shall be either DR-17 HDPE or approved equal. A Fernco coupler or approved equal shall be used to make the connection between dissimilar pipe materials. The Fernco shall be completely encased with concrete down to firm native ground. The contractor shall fuse the HDPE in accordance with manufacturer specifications. Fused butt joint material in the interior of the pipe shall be removed. The inside of the pipe shall be free of any burrs or rough edges that may collect material passing through the service line; and
  - V. Sewer service pipe lining material shall conform to the manufacturer's recommendations. Existing clean out connections or other connections must be cut out of the lining to an equivalent diameter at the connection location(s). A Fernco coupler or approved equal shall be used to make the connection between dissimilar pipe materials. The Fernco shall be completely encased with concrete down to firm native ground.
  - VI. Permitting, testing, and inspection per City Code is required when pipe bursting or lining an existing sewer service line. Final acceptance shall be at the discretion of the City of Great Falls Engineering Inspectors.
  - VII. During construction or after completion of in place lining, the contractor shall contact the City of Great Falls PWD to TV the connecting sewer main to check for protrusions of lining into the City main. Lining shall not extend more than ¼" into the main at the location where the service enters the main. The costs of all video inspection by City staff will be billed to the contractor.
- G. Force Sewer Service line:
- I. In the event that the existing sewer service cannot be repaired, burst, lined, or a new gravity sewer service cannot be installed, the option to install a grinder pump/force sewer service line will be accepted on a case by case basis to be evaluated before installation by the City Engineer's Office;
  - II. Minimum pipe strength shall equal or exceed Schedule 40 PVC or Class 200 SDR 21 PVC and shall meet or exceed 1.5 times the pump manufacturer's recommended maximum pressure;
  - III. Minimum pipe diameter shall be 2-inches;
  - IV. Fernco coupler or approved equal, encased in concrete, shall be used to make connection between dissimilar pipe materials (with approval from the City Engineer's Office, fully pressure rated Transition Couplings or Transition Fittings may be used);
  - V. A minimum 4-inch diameter cleanout is required within one foot of the transition from the new force service line to the new or existing downstream gravity line.

- VI. The cleanout is not permitted to be installed in the public right-of-way;
  - VII. No force sewer line shall discharge directly into the City sewer main; and
  - VIII. Permitting, testing, and inspection per City Code is required when installing a force sewer service line.
- H. Materials:
- I. Gravity sewer services shall have a minimum 4-inch internal diameter and be sized as required for the design flow;
  - II. Gravity sewer service pipe shall have a minimum strength of SCH 40 PVC or be ductile iron pipe from the main to the interior of the structure. Gravity sewer service pipes that are 8 to 15 inch in diameter shall be PVC ASTM D 3034 SDR 35 and/or SDR 26 PVC. Gravity sewer service pipe and fittings shall utilize Styrene Butadiene Copolymer (SBR) gaskets. In areas with hydrocarbon contamination Acylonitrile Butadine (NBR) pipe joint gaskets shall be utilized;
  - III. Schedule 40 PVC fittings shall be connected according to manufacturer's recommendation using purple primer along with the appropriate colored solvent cement;
  - IV. Connections between existing service and new or repaired service piping shall be by use of stainless steel banded flexible couplings encased in concrete as approved by the City Engineer or designee;
  - V. Fully pressure rated Transition Couplings or Transition Fittings that meet or exceed the requirements of ASTM D2513 Category 3 as manufactured by Poly-Cam or equal and approved by the City Engineering Office can be used in place of stainless steel banded flexible couplings when joining plastic pipes together; and
  - VI. Force service lines sized as required to provide 3-feet per second velocity, shall be PVC pressure pipe, ASTM 2241, Class 200 SDR 21 or Schedule 40, and force service lines shall meet or exceed 1.5 times the pump manufacturer's recommended maximum pressure.
- I. Taps
- I. Taps for Gravity service lines that are smaller than 8-inches in diameter shall only be made at the main:
    - a. With an appropriately sized PVC wye for new construction; or
    - b. With an appropriately sized and installed Inserta Tee® for connections to existing mains.
  - II. Taps for gravity service lines 8-inches and larger shall be made at a manhole; and
  - III. Taps for Force service lines shall only be made at a manhole.
- J. The minimum gravity sewer service grade shall be 2%. A grade down to 1% is only allowed under special conditions and only with the approval of the City Engineer's Office.
- K. The terminal end of sanitary sewer services at undeveloped lots shall be marked with a steel T-Post buried to within 6-inch of the surface.
- L. Double wrap all ductile or cast iron pipe and pipe fittings, located underground, with polyethylene encasement in accordance with the following:
- I. The inner layer of polyethylene wrap shall be V-Bio which shall consist of three layers of co-extruded linear low density polyethylene (LLDPE);
  - II. The outside layer of polyethylene wrap shall be 4 Mil Cross Laminated High Density Polyethylene; and
  - III. At no time will "slings" or "straps" come into contact with the polyethylene; and

- IV. Polyethylene adhesive tape shall be used for all repairs to the wrap.
- M. Utilize a wax tape system designed for below ground applications (that consists of three separate parts, a primer, wax tape #1, and an outer wrap, such as supplied by Trenton Corporation) on metal components including, but not limited to, the entire flange, all bolts on mechanical and flanged joints, restraints, sleeves, couplers, and valves.

#### 6.2.4 Pipe Bedding

- A. Shall be placed in accordance with CoGF detail 5-31;
- B. Shall be haunched under pipe with shovel;
- C. Type 1 bedding shall conform to MPWSS Section 02235 CRUSHED BASE COURSE  $\frac{3}{4}$  inch Minus;
- D. In the event ground water prohibits the use of  $\frac{3}{4}$  inch minus base course,  $\frac{3}{4}$  inch minus washed round rock aggregate may be used, with the Engineers approval, under the following conditions:
  - a. Filter fabric shall be laid on the excavated ditch bottom and encase the bedding and pipe;
  - b. The open graded aggregate shall be free draining and non-plastic;
  - c. The open graded aggregate shall conform to all applicable portions of MPWSS Section 02221, Type 1 Pipe Bedding, and shall generally be  $\frac{3}{4}$ " minus washed round rock (non-crushed or non-fractured) meeting the gradation requirements as specified below:
    - Passing the 1" Sieve - 100% by weight
    - Passing the  $\frac{3}{4}$ " Sieve – 90-100% by weight
    - Passing the #4 Sieve – 0-10% by weight
  - d. Trench plugs, as defined by CoGF detail 5-34, shall be installed once every 100 feet;
- E. Place Type 1 Pipe Bedding from 4 inches below the bottom of the pipe, around the pipe, and up to 6 inches over the pipe;
- F. The use of roller buckets and/or vibratory plates for compaction within a public utility trench is not allowed;
- G. The use of "Recycled Asphalt" as bedding, backfill, or base course is not allowed;
- H. The use of "Recycled Concrete" as bedding or as a substitute for washed gravel is not allowed;
- I. The use of "Recycled Concrete" as backfill is only allowed when blended with other materials and only when approved by the City Engineer's Office;
- J. The use of Concrete Washout as bedding and/or backfill is only allowed when approved by the City Engineer's Office;
- K. Pipe bedding for all Polyethylene wrapped pipes shall consist of a clean sand meeting the following requirements:
  - a. 100% passing the  $\frac{1}{4}$ -inch Sieve, 10 – 40% passing the No. 8 Sieve, and 0 – 10% passing the No. 16 Sieve;
  - b. The liquid limit for the material passing the No. 40 Sieve is a maximum of 25; and
  - c. The plasticity index shall not exceed 0.

#### 6.2.5 Detectable Warning Tape

- A. Shall be installed above all sanitary sewer gravity and force mains.



- B. Shall be a minimum of 5 mils thick.
- C. Shall be 3 inches wide.
- D. Shall conform to APWA colors.
- E. Shall be buried 12 to 24 inches below the final grade.

#### 6.2.6 Marker Posts

- A. Shall be used when a gravity sewer main or sewer force main is located outside a paved surface;
- B. Shall be fiber glass (FlexPost®) and a minimum of 5-feet tall, minimum of 3.5-inches wide and include the CoGF PW Utility Division contact information.
- C. Shall conform to APWA colors;
- D. Shall be installed at manholes (gravity mains); and
- E. Shall be installed at every manhole, valve, or change in direction (force mains).

### 6.3 MANHOLES

#### 6.3.1 Manhole Design

- A. Shall be Eccentric type per CoGF detail 5-65;
- B. Shall be provided at a maximum of every 450 feet, terminations, changes in pipe diameter, changes in slope, and changes in direction;
- C. Provide a minimum 1-foot distance between all outside edges of individual pipe penetrations (measured along the inside wall);
- D. The outside of any pipe shall not encroach within 6 inches of a precast joint and/or as recommended by the manufacturer;
- E. Shall be a minimum diameter of 4 feet and follow the National Precast Concrete Association [Manhole Sizing Recommendations](#).
- F. Inverts:
  - I. The invert of the outlet pipe shall be a minimum of 0.1 feet lower than the invert of the lowest inlet pipe when the flow path is in a straight line;
  - II. The invert of the outlet pipe shall be a minimum of 0.2 feet lower than the invert of the lowest inlet pipe when the flow path is not in a straight line through the manhole;
  - III. The invert of the outlet pipe shall be a maximum of 0.4 feet lower than the invert of the highest inlet pipe, unless a “drop inlet” is installed;
  - IV. Generally speaking, based on constructability of a “drop inlet” the inlet piping cannot be installed between 0.4 feet and 1.5 feet above the outlet piping invert; and
  - V. Changes in direction greater than 90° within a single structure are prohibited.
- G. When pipe diameters change at the manhole, the design capacity flow depth of the smaller inlet pipe(s) shall be at the same elevation as the design capacity flow depth of the larger outlet pipe. The design capacity flow depth shall be 0.8 times the pipe diameter.
- H. Flow channels:
  - I. Are required on all sanitary manholes;
  - II. Shall provide smooth transitions between inlet and outlet pipe inverts; and
  - III. Shall be as deep as the design capacity depth as shown in Table 1 before the start of the sloped shelf within the manhole.
- I. Manholes shall be designed to counteract buoyant forces associated with the installation location.

- J. The top of the manhole lid shall be set between 1/8-inch and 1/4-inch below the asphalt/concrete finish grade. In gravel surfaced areas, it shall be set 1-inch below the gravel finish grade.

6.3.2 Manhole Construction

- A. Shall be constructed in accordance with CoGF detail 5-65.
- B. Doghouse style manholes are allowed.
- C. Manhole Rings and Covers
  - I. Shall be as shown in CoGF detail 5-63, or approved equal. Paint is optional.
  - II. Watertight gasket manhole covers shall be used in all locations where flooding may occur.
  - III. Manhole cover if installed shall be set 1/2" ± 1/8" below finished grade.
- D. Manhole Testing shall conform to the requirements of MDEQ Circulars:
  - I. Hydrostatic Testing (only allowed when ground water is below bottom of manhole during testing):
    - a. Plug pipes in manhole; remove water in manhole; observe plugs over period of not less than 2 hours to ensure there isn't any leakage into manhole;
    - b. Determine groundwater level outside manhole;
    - c. Fill manhole with water to top of cone. Prior to test, allow manhole to soak for up to 24 hours. Water may be added over a 24 hour period to compensate for losses due to evaporation and absorption;
    - d. Following the 24 hour saturation period any loss of water within a 30 minute period shall be a failed test and the manhole must be rejected; and
    - e. Repair or replace (and test again) all manholes that do not meet the leakage test, or are unsatisfactory from visual inspection, to conform to the requirements herein.
  - II. Pneumatic Testing - vacuum test in accordance with ASTM C1244 and as follows:
    - a. Plug pipe openings; securely brace plugs and pipe;
    - b. Inflate compression band to affect seal between vacuum base and structure; connect vacuum pump to outlet port with valve open; draw vacuum to 10 inches of Hg; close valve; start test;
    - c. Determine test duration for manhole from the following table:

**Table 2 – Manhole Test Period**

Manhole Diameter	Test Period
4 feet	60 seconds
5 feet	75 seconds
6 feet	90 seconds

- d. Record vacuum drop during test period; when vacuum drop is greater than 1 inch of Hg during test period, repair and retest manhole; when vacuum drop of 1 inch of Hg does not occur during test period, discontinue test and accept manhole.
- e. When vacuum test fails to meet 1 inch Hg drop in specified time after repair, repair and retest manhole.

### 6.3.3 Manhole Damp-proofing

- A. Manholes shall be damp-proofed at the direction of the City Engineer's office on an as needed basis. Manholes that potentially require damp proofing include:
  - I. Development connections to existing brick manholes that have yet to be damp-proofed.
  - II. Manholes with high potential for Hydrogen Sulfide (H<sub>2</sub>S) gas corrosion
  - III. Manholes with force mains discharging into the manhole.
- B. All exposed interior surfaces of the manhole structure to be installed, including walls, floor, grouted areas, and ring and cover shall be damp-proofed as follows:
  - I. Materials
    - a. Epoxy modified skim coat mortar – Tnemec Mortar Clad Series 218, or equal.
    - b. Hydrophobic aromatic polyurethane – Tnemec Series 446 Perma-Shield MCU, or equal.
  - II. Surface Preparation
    - a. All surfaces to be coated shall be clean and dry. All dirt, dust, sand, grit, mud, oil, grease and other foreign matter shall be removed. Prepare all surfaces to be coated per Steel Structures Painting Council Specification SP 13 (Surface Preparation of Concrete) or SP 6 (commercial Blast Cleaning).
  - III. Application
    - a. Apply the specified epoxy modified mortar skim coat and hydrophobic aromatic polyurethane to all interior surfaces per the manufacturer's application instructions. Patch and fill voids ¼" to ½" in depth. Apply skim coat covering 100% of all concrete surfaces at 1/16" to 1/4" spread rate. The hydrophobic aromatic polyurethane shall be brushed, rolled or sprayed on in two coats, 8-10 dry mil thickness per coat, 16-20 dry mil total thickness. Concrete surfaces shall be cured and dry prior to coating.
  - IV. Curing
    - a. Curing shall adhere to manufacturer's curing and drying schedule. Coatings must be fully cured and dried before placing the manhole into service.

## 6.4 **LIFT STATIONS**

### 6.4.1 Lift Station Design

- A. Meet the design requirements of *MDEQ Circular 2*, with the following additional requirements.
- B. CoGF owned and maintained lift stations shall have a minimum discharge pipe size of 4-inches.
- C. A written report shall be submitted for any project that will create a new sewage lift station. The report shall contain, but not be limited to, the following:
  - I. A description of the proposed wet well, pumping system, and force main;
  - II. The capacity of the recommended pumps and potential for future upgrades;
  - III. A map showing the potential lift station service area;

- IV. The average and peak design flows for the proposed project and for the potential service area;
  - V. The hydraulic capacity of the force main;
  - VI. The reserve capacity of the lift station when the proposed project is on line at full capacity (full build out);
  - VII. The pump run and cycle times for the average and peak design flows;
  - VIII. Strategies for improvements which may be necessary to accommodate future sewer extensions (i.e. increased storage, increased pumping, or auxiliary power capacity);
  - IX. A statement of the pump selection process, including the Engineer's calculations for the total dynamic head, total discharge head, net positive suction head, and other pertinent pump selection criteria; and
  - X. The designed pump operating curve plotted on a manufacturer's pump performance chart with the design operating point clearly identified.
- D. A written report shall be submitted for any project that will contribute to an existing sewage lift station. Generally speaking the report only needs to evaluate the first downstream lift station. The report for a project that will contribute to an existing lift station shall contain, but not be limited to, the following:
- I. A description of the existing wet well, pumping system, and force main;
  - II. The capacity of the existing pumps and potential for future upgrades;
  - III. A map showing the potential lift station service area;
  - IV. A list of the existing users and their average design flows;
  - V. The existing peak design flow and reserve capacity;
  - VI. The proposed average and peak design flows to the lift station;
  - VII. The hydraulic capacity of the force main;
  - VIII. The reserve capacity of the lift station when the proposed project is on line at full capacity (full build out);
  - IX. The pump run and cycle times for the existing average and peak design flows;
  - X. The pump run and cycle times for the proposed average and peak design flows; and
  - XI. Recommendations for improvements, if necessary, to enable the lift station to serve the proposed project;
- E. An emergency power supply will be required for all lift stations unless approved by the Public Works Director. If the available 50kW portable generator is acceptable for emergency power, a plug-in shall be provided (Appleton Electric Co. Power Tite, Catalog # ACR 6034, 60 amp, 250 VDC, 600 VAC or 100 amp equivalent depending on station size. In addition, a normal to emergency power switch shall be provided (Culter Hammer double throw safety switch, 60 amp, 600 volts, ac or 100 amp equivalent depending on station size).
- F. Upon request from the Public Works Director, the Design Engineer shall submit a list of three lift stations of the type proposed which have been in operation for at least five years. The City reserves the right to accept or reject the proposed lift station.
- G. An alarm system that is compatible with the City's alarm system shall be provided.
- I. The alarm system shall be capable of detecting power interruption, phase loss, low water, motor failure, seal failure (motor moisture sensor), high water, and high-high water conditions;
  - II. An hour meter is required on each pump;
  - III. Amperage meters are required on each leg of the electrical wiring;

- IV. Surge/lighting protection is required on all control panels;
- V. Cathodic protection is required for all lift stations having a metallic exterior;
- VI. The Design Engineer shall submit an analysis of the amount of cathodic protection required. The system should be Impressed Current with standard amperage monitoring and should have maintenance check points available; and
- VII. The station wet well should be equipped with high level tip over float with a run timer for backup pump start or be equipped with a dual backup tip over float system for stop and start commands. It is recommended that either system command a dual pump run scenario.

#### 6.4.2 Lift Station Construction

##### A. Manufacturer

- I. Gorman Rupp; or
- II. Equal as approved by CoGF PWD
  - a. Design Engineer shall provide all necessary information to justify the product as equal;
  - b. Design Engineer shall submit a list of 3 lift stations of the type proposed which have been in operation at least 5 years;
  - c. The CoGF reserves the right to accept or reject the proposed lift station;
  - d. If the station is a drywell/wet well can configuration such as is built by Dakota, a four foot egress tube is required with a mid-range fall protection platform;
  - e. Any hatches shall be aluminum or stainless steel for easy Vacuum Truck or pump pulling accessibility; and
  - f. Any wet well equipment (i.e. pull rails/chains, etc.) above water level shall be made of stainless steel for minimal corrosion.

##### B. Pump Type

- I. Submersible or submersible grinder; or
- II. Above ground, self-priming, suction lift;
  - a. Only to be used with approval on a case by case determination.

##### C. Redundancy

- I. Duplex systems
  - a. Minimum requirement for all systems.
- II. Triplex systems
  - a. May be required by the City Engineer for large lift stations or lift stations requiring specialty items.
- III. Each motor shall include a motor saver.

##### D. Influent Pipe

- I. One full joint of Class 50, cement lined, ductile iron; and
- II. Spigot end shall extend 6-inches beyond interior of wet well wall.

##### E. Access Road

- I. 12-foot minimum width paved for access by sewer maintenance vehicles; and
- II. Access approach from street per Standards.

##### F. Bypass

- I. Shall have a dedicated valve;
- II. Shall connect downstream of the lift station check valves; and

- III. Provide a 4-inch cam-lock style connection with cap.
- G. Electrical
  - I. Wiring
    - a. Shall be water resistant inside the lift station and enclosure.
  - II. Backup Power
    - a. Generac or approved equal;
    - b. Diesel fueled or approved fuel source;
    - c. Noise emissions not to exceed 65 dbA at 20 feet from the power supply;
    - d. Shall be installed on concrete pad per manufacturer recommendations;
    - e. Shall include an appropriately sized transfer switch, manufactured by the same manufacturer as the generator;
    - f. Shall include an O&M manual; and
    - g. Manufacturer shall perform training at startup.
  - III. Alarms
    - a. Manufacturer:
      - i. Mission Communications
    - b. Model
      - i. M-110
        - a) Lift stations with pump motors under 20 horsepower.
      - ii. M-800
        - a) Lift stations with pump motors over 20 horsepower;
        - b) Include a Digital Expansion Board to add 8 digital inputs; and
        - c) Include an Analog Expansion Board to add 4 analog inputs.
    - c. Alarm Conditions
      - i. High water;
      - ii. Low water;
      - iii. Seal failure;
      - iv. Power interruption; and
      - v. High motor temp.
  - IV. Controls
    - a. Each pump shall have:
      - i. Hour meter;
      - ii. Suction pressure gauge tap and valve; and
      - iii. Discharge pressure gauge tap and valve.
    - b. Pump run alternator;
    - c. Amperage meter on each leg of the electrical wiring;
    - d. Uninterruptible Power Supply (UPS) for lightning/surge protection for the power supply and other instrumentation. It also should provide a minimum of 20 minutes of backup power to the PLC and the level transducer. The UPS should not be hardwired but should be of the 120 volt plug-in configuration for ease of change out;
    - e. Level control
      - i. Primary control – Pressure transducer (said transducer shall be a submersible KPSI type with standard range of 0-23 feet and 0-10

- psi). A wet well level indicator shall be provided on the drywell side or in above ground control panels.
    - ii. Backup control – 5 float mercury switch system
      - a) Shall be installed and function if primary control is lost
  - f. Transfer switch and control panels shall be placed on a steel frame and embedded in concrete a pad with a pitched roof covering the pad and controls.
  - g. Station controls should include an Allen Bradley Micro Logic 1100 PLC or current upgrade. Depending on station size, it should also include an Allen Bradley Panel view for control and monitoring. Controls should also include applicable analog input and output cards.
  - h. If the control panel is above ground, it shall be equipped with a heat system to keep all electronics above 32° F.
- V. Communications
  - a. Current communication protocol is cell phone and includes:
    - i. SIM-Verizon LTE insertion assembly (ordered thru Veolia)
    - ii. Low-power Draw 3G/4G Gateway Single Drive Item #1102555
    - iii. LTE Broadband Antenna (Item #MM-S-DSMM00-03B-03)
    - iv. Dual LTE Combo Antenna (# MM-D-DSM00-03B-15)
    - v. Antenna Mount Kit (Item # GB-06)
    - vi. 24 volt power supply
  - b. If the station is equipped with a landline phone system:
    - i. Allen Bradley Modem – 9300 Rad Kit
    - ii. Physical address of the station will be needed for phone co.
    - iii. Phone line shall be plugged into the UPS.
- VI. Lighting
  - a. Yard lighting shall be provided and connected to the power supply; and
  - b. Street lighting shall not be considered adequate to meet this requirement.
- VII. Miscellaneous Electrical
  - a. Adjustable frequency drives (AFD's) and soft starts should be considered for larger facilities/pump configurations.
  - b. Power supply should be 480 volt, 3 phase. Single phase configuration is unacceptable.
  - c. Above ground pull boxes adjacent to the wet well are preferable for easy replacement of floats and level transducers. This eliminates dangerous confined space entry.
  - d. Drywells shall be equipped with a sump pump and float alarm in case of flooding.
- H. Enclosures
  - I. Foundation
    - a. Monolithic concrete
    - b. Minimum 4 inches thick
    - c. Treated sole plate anchored to foundation
  - II. Roof
    - a. Gable style
    - b. Trusses spaced at 24 inch maximum

- c. Designed to meet local snow load requirements
  - d. 4:12 slope
  - e. 5/8 inch OSB sheathing
  - f. 30-year 3-tab shingles
- III. Walls
- a. 8 foot floor to ceiling height
  - b. 6 inch wall studs
  - c. R-19 insulation
  - d. Exterior
    - i. 1/2-inch OSB sheathing; and
    - ii. Lap siding with 7-inch reveal
  - e. Interior
    - i. T-111 siding
- IV. Ceiling
- a. R-49 insulation
  - b. 5/8-inch unfinished gypsum board
- V. Other
- a. 3068 steel door with deadbolt lock
  - b. Heating and air circulation systems
  - c. Ceiling mounted industrial lights in protective cages
  - d. All other necessary materials for a finished building
- VI. Submittals by Design Engineer for CoGF Planning and Community Development approval
- a. Structural plans
  - b. Mechanical plans Electrical plans
  - c. Heating and air circulation
- I. Fencing
- I. 6-foot chain link security or equivalent
  - II. 3-foot wide personnel gate
  - III. 12-foot wide gate with two 6-foot leaves
  - IV. Shall provide adequate room for access and facility maintenance
  - V. 3-foot minimum offset from all structures and appurtenances
  - VI. Gate placement shall promote maintenance vehicle access for pump removal
  - VII. Gate installations shall include duckbill style gate holdbacks
- J. Landscaping
- I. 4-inches of clean 1-inch minus gravel or other landscaping rock as approved by CoGF PWD for areas outside of public right-of-way; and
  - II. Areas inside public right-of-way shall meet the requirements of the CoGF Municipal Code and this standard.

## **6.5 INTERCEPTORS AND SEPARATORS**

### **6.5.1 Grease Traps and Interceptors**

- A. In accordance with the OCCGF Title 13 and the City of Great Falls Fats Oils and Grease Program Manual and Management Policy grease traps and interceptors are required at all



establishments that have the potential to introduce Fats Oils or Grease, excessive food waste, or other wastes to the sanitary sewer that may congeal or form blockages and sanitary sewer overflows and undergo any of the following activities after January 1, 2017:

- I. New Construction;
- II. Interior remodeling to accommodate expansion or operational modifications;
- III. Changes in occupancy or use;
- IV. Facilities which are experiencing difficulty in achieving compliance with maintenance and / or waste water discharge limitations; or
- V. Any facility that has been determine by the City through reasonable investigation to be causing or contributing to blockages, impaired function or violation of any of the Industrial Pretreatment General or Specific Prohibitions in of the sanitary sewer or lift station(s).

Controls that are designed and constructed in pursuant to these standards are subject to review and approval by the City's Industrial Pretreatment Program Coordinator prior to construction. For additional information contact the City of Great Falls Pretreatment Coordinator's Office at (406) 727-8390;

- B. For the purpose of these standards, Grease Traps are defined as smaller interior devices often located in the kitchen space and or under fixtures and that have an overall volume of less than 100 gallons. Grease Interceptors are defined as larger devices located (usually) exterior to the building and subterranean, that have an overall volume greater than 500 gallons and are located on a sanitary sewer service line. For additional information contact the City of Great Falls Pretreatment Coordinator's Office at (406) 727-8390;
- C. The standards in parts 6.5.2 and 6.5.3 apply to establishments that include but are not limited to:
  - I. Breweries,
  - II. Butcher Shops,
  - III. Churches,
  - IV. Commissaries,
  - V. Grocery Stores,
  - VI. Mobil Food Units,
  - VII. Hotels\Motels,
  - VIII. Nursing Homes and Assisted Living Facilities,
  - IX. Department Store Eateries,
  - X. Cinemas,
  - XI. Cafes and Coffee Shops,
  - XII. Smoothie, or Juice Shops,
  - XIII. Ice Cream Shops,
  - XIV. Fairground Eateries,

- XV. Rented Commercial Kitchens, and
- XVI. Restaurants of all types.

#### 6.5.2 Grease Traps Design and Construction Standards

- A. Sizing for traps shall comply with current Uniform Plumbing Code requirements and utilize the formula that uses fixture capacities (Minimum size allowed is 20 gpm.);
- B. Design shall comply with Standard Drawing 5-76;
- C. Traps, the associated sample port and flow restrictor orifice shall be located in an area that allows easy access for sampling, inspection, and cleaning;
- D. Both above grade and below grade traps shall be properly vented and utilize a vented flow restrictor on the inlet line to the trap or at the fixture discharge line.
- D. Traps shall have a sample port installed on the effluent line from the trap;
- E. Food preparation sinks, dishwashing sinks and floor drains shall discharge into the trap;
- F. Water entering the interceptor shall not exceed 140°F; and
- G. Designs including food processors\grinders upstream of the trap must also contain a solids collector upstream of the trap, an appropriate (more frequent), maintenance schedule, or other configuration approved in writing by the City's Industrial Pretreatment Coordinator prior to construction.

#### 6.5.3 Grease Interceptors Design and Construction Standards

- A. Food preparation sinks, dishwashing sinks and floor drains shall discharge into the interceptor;
- B. Sizing for interceptors shall comply with the current Uniform Plumbing Code requirements (Minimum size allowed is 500 gallons.);
- C. Design shall comply with Standard Drawing 5-75;
- D. Gravity grease interceptors shall have a sample port installed in accordance with Standard Drawings 5-75 and 5-70;
- E. Gravity grease interceptors shall be properly vented;
- F. Interceptor and sampling ports must be located in an area that easily accessible for sampling, inspection and cleaning;
- G. Interceptor and sample port lids must be installed in a manner that allows for easy removal during sampling, inspection and cleaning;
- H. Low temperature, sanitizing rinse, mechanical dishwashers are recommended;
- I. Water entering the interceptor shall not exceed 140°F unless approved in writing by the City's Industrial Pretreatment Coordinator prior to construction;
- J. Designs including food processors\grinders upstream of the trap must also contain a solids collector upstream of the trap, an appropriate (more frequent), maintenance schedule, or other configuration approved in writing by the City's Industrial Pretreatment Coordinator prior to construction; and
- K. Enzymes and drain maintenance chemicals are prohibited.

#### 6.5.4 Sand, Oil Interceptors

- A. For the purpose of these standards Sand Oil Interceptor (SOI) are defined as multi-compartment tanks installed on sanitary sewer service line and designed to physically

separate solids and liquids that are lighter and heavier than water from the waste water stream. SOIs are larger structures with a minimum size of 500 gallons that may be installed either internally or external to a building envelope, depending on the application. Industrial Users (as defined at OCCGF Title 13) that have the potential to discharge floatable liquids or solids, sediment and/or other wastes capable of impairing sanitary sewer function are required to install a SOI. Facilities commonly falling into this category include:

- I. Facilities with floor drains;
  - II. Truck or heavy equipment washes;
  - III. Commercial car washes;
  - IV. Automotive service shops;
  - V. Storage facilities and warehouses;
  - VI. Parking garages or indoor parking facilities;
  - VII. Laundromats; and
  - VIII. Other Industrial users that do not require more advanced controls to meet discharge permit requirements.
- B. In accordance with the OCCGF Title 13, SOIs are required at all establishments that meet any of the following criteria after January 1, 1987:
- I. New Construction of any facility listed in A. above;
  - II. Interior remodeling to accommodate expansion or operational modifications at any facility listed in A. above;
  - III. Changes in occupancy or use to any facility listed in A. above;
  - IV. Any facility experiencing difficulty in achieving compliance with maintenance and / or waste water discharge limitations; or
  - V. Any facility that has been determine by the City through reasonable investigation to be causing or contributing to blockages, impaired function or violation of any of the Industrial Pretreatment General or Specific Prohibitions in of the sanitary sewer or lift station(s).
- C. Controls that are designed and constructed in pursuant to these standards are subject to review and approval by the City's Industrial Pretreatment Program Coordinator prior to construction. For additional information contact the City of Great Falls Pretreatment Coordinator's Office at (406) 727-8390.

#### 6.5.5 SOI Design and Construction Standards

- A. Each business or establishment that requires a SOI shall have a SOI serving only that establishment. Common or shared SOI's are not permitted;
- B. Sizing shall be determined using the SOI Sizing Calculation with a minimum size of 500 gallons as follows:
  - I.  $SOI\ Capacity = (Process\ floor\ space\ in\ ft^2 / Use\ factor\ from\ Table\ below) * 7.48$  gallons

Use Category <sup>1</sup>	Use Factor
Truck Wash, Heavy Equipment Wash or Commercial Car Wash	3 ft <sup>2</sup>
Commercial Car Wash (Hand Sprayer)	6 ft <sup>2</sup>
Automotive Service Shop or Machine Shop	15 ft <sup>2</sup>
Storage Area or Warehouse	100 ft <sup>2</sup>
Parking Garage <sup>2</sup>	1,000 ft <sup>2</sup>
<p>1. If your use category is not listed, contact the Industrial Pretreatment Coordinator's Office at 1(406) 727-8390.</p> <p>2. Do not use the top level of a parking garage if it is exposed to storm events. This level shall be drained to the storm drain system.</p>	

- II. The maximum size of an SOI shall be 2,500 gallons. Facilities requiring SOIs larger than 2,500 gallons shall install multiple interceptors in series to accommodate the additional load on the system.
- C. Design and construction shall comply with Standard Drawing 5-71;
- D. SOIs shall be equipped with a sample port and the sample port shall comply with Standard Drawing 5-70;
- E. SOIs shall be properly vented;
- F. SOIs and the associated sample port shall be located in an area that allows easy access for sampling, inspection, and cleaning;
- G. SOIs are not to be located in parking spaces or driveways with heavy traffic;
- H. The SOI lid shall have oil absorbent pads in place at the functional liquid surface level in the primary chamber;
- I. Laundry equipment in Commercial Buildings may be required to discharge through a wire basket and SOI as determined necessary by the City Building Official or Pretreatment Coordinator; and
- J. Elevator pits with sump pumps shall not be directly connected to the sanitary sewer system unless approved in writing by Pretreatment Coordinator whom can be contacted at (406) 727-8390.

# CHAPTER 7 - STORM SEWER SYSTEMS

## Chapter 7 Storm Sewer Systems

### 7.1. GENERAL PROVISIONS

- 7.1.1 Refer to the [City of Great Falls Storm Drainage Design Manual](#) latest implemented version for the City's storm drainage system design and construction standards.
- 7.1.2 The developer may elect to utilize PVC storm water piping within the Right of Way, so long as manufacturer's recommendations for minimum and maximum depth of cover are met, and the bedding on the top of the pipe does not extend into the roadway section. PVC storm drainage pipe shall meet one of the following specifications.
  - A. Pipe Sizes 4" to 15" – ASTM 3034 SDR 35
  - B. Pipe Sizes 18" to 24" – ASTM F679 SDR 35
  - C. Pipe Sizes greater than 24" - Reinforced Concrete Pipe (RCP) ASTM C76, Class III Minimum. RCP pipe is an acceptable substitute for any storm drainage pipe.

# CHAPTER 8 - TRANSPORTATION SYSTEMS

## Chapter 8 Transportation System

### 8.1. DESIGN STANDARDS

#### 8.1.1 General

- A. Roadway systems, including private roadways, shall be designed in accordance with the current edition of the Standards (this document), the current AASHTO guidelines, the current [Manual on Uniform Traffic Control Devices](#) (MUTCD), and the [CoGF Official Code](#). Any conflicts or differences in these documents shall be resolved in favor of the CoGF Official Code, then these Standards, and then MUTCD.
- B. All roads within a proposed subdivision shall be designed by a professional engineer and approved by the City Engineering Office.

#### 8.1.2 Traffic Impact Analysis (TIA)

- A. Required when the peak hour traffic of the proposed development at build-out exceeds three hundred (300) trip ends. When the peak hour traffic is between two hundred (200) and two hundred ninety-nine (299) trip ends, the CoGF may require a traffic impact analysis when circumstances warrant such review;
- B. Shall be prepared and stamped by a professional engineer as approved by the CoGF, with expertise in transportation planning;
- C. Trip generation rates for various land uses shall be based on the manual entitled “Trip Generation” (latest edition) published by the Institute of Transportation Engineers;
- D. Trip generation rates from other sources may be used if it can be shown that the alternative source better reflects local conditions;
- E. The development shall maintain or improve the existing LOS of the affected roadways;
- F. Complete in accordance with MDT requirements and nationally accepted standards;
- G. Contents:
  - I. The study’s purpose and goals;
  - II. A description of the site and study area;
  - III. Existing traffic conditions:
    - a. Roadway geometries;
    - b. LOS of each intersection;
    - c. Traffic counts;
    - d. Crash analysis; and
    - e. Road capacity analysis
  - IV. Anticipated nearby land developments and transportation improvements;
  - V. Analysis and discussion of trip generation, distribution, and modal splits;
  - VI. The traffic assignment resulting from the proposed development;
  - VII. The projection and assignment of future traffic volumes;
  - VIII. Identify all negative impacts associated with the proposed development including LOS impacts;
  - IX. Thoroughly detail a mitigation plan for the negative impacts based on nationally accepted standards and resources;
  - X. Recommendations for off-site improvements to the primary access and related transportation facilities and infrastructure which are directly attributable to the development; and



- XI. Account for other forms of transportation, including bicycle and pedestrian.
  - XII. An analysis of problem intersections as determined by the Transportation Planner within 1 mile.
- H. Study limits shall be determined by the City Engineering Office.

#### 8.1.3 Intersections

- A. Design in accordance with the current version of AASHTO A Policy on Geometric Design of Highways and Streets (AKA AASHTO Green Book);
- B. Streets shall intersect at 90° angles, if topography permits, but in no case shall the angle of the intersection be less than 75° for a minimum distance of 60 feet as measured along the centerline, from the right-of-way line at the intersecting street;
- C. No more than two streets may intersect at one point;
- D. Two streets meeting a third street from opposite sides shall meet at the same point, or their centerlines shall be offset at least 125 feet for local roads and 300 feet for collectors;
- E. Intersections of local streets with arterials shall be kept to a minimum;
- F. Maximum straight tangent grade of approach to any intersection shall not exceed 2% for a distance of 60 feet as measured from edge of transverse pavement to provide for adequate starting, stopping, and stacking distances; and
- G. The back of curb radius at a street intersection shall be 22.5 feet.
- H. The grade and crown of the principle street shall continue through the intersection. At intersections of roadways with the same classification, the roadway with more peak hour trips, or as directed by the City Engineering Office, shall take precedence. Side streets shall warp at intersections to match the through street. The side street crown warp transition shall occur within 75 feet to 150 feet horizontally of the center of the intersection. The pavement cross slope of the warped street shall not exceed 5%, or the running grade of the through street, whichever is greater.

#### 8.1.4 Dead-end Streets

- A. Dead-end streets shall meet the requirements of Title 17 of the CoGF official code;
- B. Cul-de-sacs must meet a forty-eight and one half (48.5) foot radius from center of cul-de-sac to back of curb, a sixty-one (61) foot radius on the right-of-way, and cannot be longer than five hundred (500) feet; and
- C. Temporary dead-end streets shall be approved by the Fire Chief and City Engineer.

#### 8.1.5 Sight Distance

- A. Shall be determined by design speed as required by the AASHTO Green Book; and
- B. A minimum of 200-feet is required for all horizontal and vertical curves.

#### 8.1.6 Local, Collector, and Arterial Streets

- A. Location shall comply with the [City of Great Falls Growth Policy, Long Range Transportation Plan](#), and/or any other major street and highway plan as adopted by the CoGF;
- B. The development of frontage roads or shared accesses serving new developments shall be used along collectors and arterials rather than the use of individual driveways or approaches;

- C. Temporary dead-end streets shall have a fully functional temporary cul-de-sac until the permanent street connection is made;
- D. Curved collector streets shall have a centerline radius not less than 250 feet; and
- E. Curved local streets shall have a centerline radius not less than 100 feet.

**Table 7 – Road Design Standards for Local Subdivision Streets**

<b><u>DESIGN STANDARDS</u></b>	<b><u>ARTERIAL</u></b>	<b><u>MINOR ARTERIAL</u></b>	<b><u>COLLECTOR</u></b>	<b><u>LOCAL</u></b>	<b><u>ALLEY</u></b>
Minimum Right-of-Way	110 Feet	100 Feet	80 Feet	60 Feet	20 Feet
Pavement Width	Approved by City Engineer	As approved by City Engineer	37 Feet <sup>[3]</sup>	31 Feet	16-20 Feet
Maximum Grade	5%	7%	10%	10%	10%
Minimum Grade	0.5%	0.5%	0.5%	0.5%	0.5%
Design Speed		As approved by City Engineer	35 mph	25 mph	15 mph
Crest minimum k-value	Based on Design Speed	Based on Design Speed (DS)	Based on DS	12	12
Sag minimum k-value <sup>[5]</sup>	Based on DS	Based on DS	Based on DS	26	26
Crest Vertical Curve Length	Based on DS	Based on DS	Based on DS	50 ft (min)	50 ft (min)
Sag Vertical Curve Length <sup>[5]</sup>	Based on DS	Based on DS	Based on DS	50 ft (min)	50 ft (min)
Cul-de-sac turnaround	a.	Minimum back of curb radius		48.5 ft	
	b.	Minimum right-of-way radius		61 ft	
	c.	Maximum length <sup>[4]</sup>		500 ft	

<sup>3</sup> On street parking governed by the Official Code of the City of Great Falls.

<sup>4</sup> Measured from the centerline of the intersection to the center point of the cul-de-sac.

<sup>5</sup> Drainage easements or other overflow provisions shall be provided at sag curves to prevent flooding or storm water runoff damage to adjacent properties.

**8.1.7 Traffic Control Signs, Street Name Signs and Street Names**

**A. General**

- I. The developer shall coordinate with the CoGF Traffic Foreman (406-781-8991) and pay for all necessary permanent traffic control signs. The Traffic Division shall build and install the signs;
- II. The signs shall be built by the Traffic Division in accordance with the MUTCD;
- III. Developer and/or Contractor shall contact the Traffic Foreman (406-781-8991) three (3) business days in advance of removing temporary traffic control and request that the permanent traffic control signs be installed;

- IV. Should existing permanent traffic control signs need to be temporarily removed to facilitate construction, developer and/or contractor shall install the temporarily traffic control and notify the CoGF Traffic Foreman one (1) business day in advance of needed the CoGF to remove the permanent traffic control signs;
- V. Road Name Signs shall be installed at each intersection;
- VI. New roads shall be assigned a road name per the CoGF *“Site Addressing and Road Naming Policies and Procedures Manual”*;
- VII. All proposed road names shall be submitted to the CoGF Addressing Division for approval prior to preliminary plat submittal; and
- VIII. A road naming assignment by the City to any road shall not constitute or imply jurisdiction, ownership, right of use, guarantee of access, or acceptance into the City road maintenance program.
- IX. Traffic signage and signal design shall implement the recommendations of the TIA when applicable. Coordinate all signage and signal improvements with the Traffic Foreman (406-781-8991).

B. Road Geometric Guidelines

- I. A road shall be essentially continuous, without gaps;
- II. If a road has a branch or branches, separate names shall be used for the minor branch(es); and
- III. Each road shall have the same name throughout its entire length, except that a road name may change when, and only when, there is a substantial intersection or at municipal boundaries.

8.1.8 Sidewalks:

- A. All developments shall have sidewalks which will allow pedestrians to safely travel from any part of the development to the boundaries of the development;
- B. Developments abutting existing or proposed roadways will be required to have sidewalks within the public right-of-way and parallel to the roadways;
- C. The minimum width of a sidewalk shall be 5 feet in Collector and Local right-of-ways and 8 feet in Arterial right-of-ways;
- D. The minimum width of sidewalks designated as “shared use paths” shall be 10 feet;
- E. Sidewalks are required on both sides of the street in all subdivisions;
- F. Sidewalks shall be separated from the street by a 6.5 foot wide boulevard in areas with a 60 foot right-of-way or 8.5 foot wide boulevard in areas with an 80 foot right-of-way;
- G. All sidewalks shall rise a minimum of three sixteenth (3/16) inch to the foot or one and one-half (1.5) percent and a maximum of 2% and shall slope toward the street;
- H. Sidewalks shall be configured according to the ADA requirements;
- I. New or existing sidewalk being replaced through a new or existing driveway shall meet ADA requirements, this may require the contractor to remove portions of the existing driveway;
- J. Cement concrete private walks shall be of uniform width and shall be built upon the established grade from the curb-line to the property line, and shall be not less than thirty-six (36) inches in width or more than sixty (60) inches in width (OCCGF 12.13.040.B);

- K. Provided that in front of churches, schoolhouses, nursing homes, long term care facilities, medical facilities, court houses, and other public buildings, the cement concrete private walks may be of greater width than above mentioned (OCCGF 12.13.040.B);
- L. Sidewalks shall be constructed per standard drawing 5-10C;
- M. Sidewalks shall be constructed with 6.5 sac cement and have a 28 day strength of 4,000 psi, and shall have an air entrainment between 5% and 8%; and
- N. The back of curb radius at a street intersection shall be 22.5 feet.

8.1.9 Boulevard/Open Space:

- A. Boulevard/open space shall be landscaped in accordance with the [CoGF Official City Code](#) with a plan approved by the City of Great Falls Planning and Community Development Department (406-455-8430); and
- B. Boulevards shall slope between a 1.5 and a two (2) percent from the top back-of-curb elevation to the property line to ensure positive drainage towards the street.

8.1.10 Shared Use Paths:

- A. Non-motorized shared use paths shall be designed with a 20 mph design speed and in accordance with the most recent version of AASHTO’s “Guide for the Development of Bicycle Facilities” and “Guide for the Planning, Design and Operation of Pedestrian Facilities”;
- B. Paths shall be 10 feet wide unless physical constraints limit the width, in which case the City Engineer may consider a reduction to not less than 8 feet;
- C. In limited instances, the PWD Director may require the path to be built to accommodate HS-20 loading if the path serves as an emergency or maintenance access route;
- D. No catch basins, valve boxes, curb boxes, or other utility appurtenances shall be located within the path;
- E. Signage and pavement markings shall conform to the most current MUTCD, unless otherwise approved by the CoGF;
- F. The surfacing section required on paths is 4 inches of asphalt on 8 inches of 1.5 inch minus crushed rock base compacted to 95% max dry density, when the path will not be driven on;
- G. Landings and ramps shall be constructed of concrete meeting ADA requirements and the CoGF sidewalk landing and ramp standards; and
- H. No tripping hazard or obstruction may be located within 2 feet of the edge of the shared-use path, including but not limited to sign posts or landscaping features, unless approved by the CoGF.

8.1.11 On-Street Parking:

- A. At intersections:
  - I. Shall be outside of the clear sight triangle as detailed in CoGF municipal code; and
  - II. The City Engineer reserves the right to increase clear sight triangles based on site specific conditions.
- B. Along streets:
  - I. Shall not be permitted on:
    - a. Arterials;

- b. Collectors less than 34 feet in width as measured from edge of asphalt to edge of asphalt;
- c. Local streets less than 28 feet in width as measured from edge of asphalt to edge of asphalt;
- d. Any street with a rural road section; and
- e. Streets not meeting sight distance per Section 8.1.5.

8.1.12 Driveways:

- A. Prior to the installation of a driveway curb cut or other access point onto a CoGF public street or right-of-way, the developer or owner shall obtain approval from the City Engineering Office.
- B. Prior to the installation of a driveway curb cut or other access point onto a public street or right-of-way within the CoGF and under MDT's jurisdiction, the developer or owner shall obtain approval from both the City Engineering Office and from MDT;
- C. The nearest edge of any driveway shall be not less than 35 feet from the edge of the pavement to the nearest intersecting street;
- D. Curb cut widths shall conform to the requirements of the OCCGF 17.32.150;
- E. All new driveway locations and modifications to existing driveways shall be reviewed and approved by the City Engineering Office prior to beginning construction;
- F. All driveways shall have the back of curb dropped a minimum of 4 inches for the width of the driveway and the minimum driveway transition distance shall be from the back of the curb to the property line; occurring in a uniform manner (OCCGF 12.13.070.A);
- G. Curb fillets constructed by filling the curb and gutter are prohibited as a means to transition from the street to the driveway (OCCGF 12.13.070.B);
- H. Concrete crosswalks through driveways shall conform to ADA requirements, which may require the removal of portions of the existing driveway behind the property line; and
- I. All driveways shall be constructed per standard drawings 5-10A, 5-10B, 5-10D, and/or 5-10E.

8.1.13 Placement of Utilities:

- A. See Chapter 4 in these Standards; and
- B. All applicable laws, rules and regulations of appropriate regulatory authority having jurisdiction over utilities shall be observed.

8.1.14 Traffic Calming Devices

- A. Shall be recommended by a traffic study completed by a PTOE;
- B. Shall not conflict with any operation and maintenance activities; and
- C. Shall be approved by the Transportation Planner and the City Engineering Office.

8.1.15 Guardrails

- A. In areas of excessive fill or steep back slopes, roadside guardrail shall be installed consistent with the standards in the latest version of "Roadside Design Guide" as published by AASHTO and these *Standards*; and
- B. Location, style, and design of the roadside guardrail shall be reviewed and approved by the City Engineer's Office.

8.1.16 Pavement Design

- A. A pavement design report shall be prepared for all street projects by a registered professional engineer, or qualified professional approved by the City Engineer;
- B. The pavement design report shall be submitted CoGF for review and approval;
- C. Pavement thickness shall be consistent with these *Standards*, the standards contained in the current AASHTO “Guide for Design of Pavement Structures” or the current Asphalt Institute Manual Series No. 1 (MS-1);
- D. The design shall be based on the following:
  - I. Site characteristics (e.g. soils);
  - II. Based on at least a twenty year performance period traffic volume;
  - III. The minimum design lane equivalent 18,000 pound single axle load (ESAL) used in pavement design must not be less than:
    - i. 50,000 ESAL on Local Roads;
    - ii. 200,000 ESAL on Collector Roads;
    - iii. 1,250,000 ESAL on Minor Arterial Roads; and
    - iv. 4,500,000 ESAL on Arterial Roads.
  - IV. The minimum road section for Local and Collector Roads shall be 12 inches of 1½ inch minus base course under 4 inches of asphalt;
  - V. The minimum road section for Minor Arterial Roads shall be 16 inches of 1½ inch minus base course under 6 inches of asphalt; and
  - VI. The minimum road section for Major Arterial Roads shall be 20 inches of 1½ inch minus base course under 6 inches of asphalt.
  - VII. A geotextile fabric such as Mirafi 600X (or approved equal) shall be placed between the base course and the subgrade (or between the sub base course and subgrade).

8.1.17 Standards for Back Slope and Fill Slope

<i>Cut Depth</i>	<i>Allowable Back Slope</i>
<i>0-5 feet</i>	<i>5:1</i>
<i>5-10 feet</i>	<i>4:1</i>
<i>10-15 feet</i>	<i>3:1</i>
<i>15-20 feet</i>	<i>2:1</i>
<i>&gt;20 feet</i>	<i>1.5:1</i>

<i>Fill Height</i>	<i>Allowable Fill Slope</i>
<i>0-10 feet</i>	<i>6:1</i>
<i>10-20 feet</i>	<i>4:1</i>
<i>20-30 feet</i>	<i>3:1</i>
<i>&gt;30 feet</i>	<i>2:1</i>

## 8.2. CONSTRUCTION STANDARDS

### 8.2.1 General

- A. Roadway systems, including private roadways, shall be constructed in accordance with the current edition of the *Standards* (this document), the *MPWSS*, and other standards referenced elsewhere in this document. Any conflicts or differences in these documents shall be resolved in favor of the OCCGF and then these *Standards*;
- B. Upon completion of roadway construction, a professional engineer shall certify the construction of private roadways meets the requirements of the *Standards*;
- C. When the existing asphalt thickness is greater than 4 inches, *at a minimum* the reconstructed road/trench opening shall be paved with a thickness equal to the existing thickness with Type B Asphalt Plant Mix Aggregate on top of a minimum of a 12-inch thick base course meeting the 1½ inch minus. If the existing base course and or sub base gravel sections exceed 12 inches, the gravel sections shall match the existing section thicknesses; and
- D. Road section thickness shall meet the minimum requirements of these *Standards* unless the Geotechnical Report recommends thicker sections.

### 8.2.2 Materials:

- A. Asphalt:
  - I. At a minimum, all new roads or reconstructed roads shall be paved with a minimum of 4 inches of Type B Asphalt Plant Mix Aggregate, (PG 58-28) asphalt binder, and shall be accomplished in accordance with current MPWSS; and
  - II. PG 64-28 Polymer Modified shall be used when required by MDT and/or PWD Street Manager.
- B. Crushed base:
  - I. The crushed base for streets shall be 1½ inch minus crushed stone in accordance with MPWSS Section 02235 and shall meet all requirements of said section;
  - II. All new roads or reconstructed roads shall have a minimum of 12-inches of 1½ inch minus crushed stone installed in accordance with the current MPWSS; and
  - III. A geotextile such as Mirafi 600X (or approved equal) shall be placed between the base course and the subgrade.
- C. Street Sub base (when required):
  - I. The sub base for streets shall be crushed stone in accordance with MPWSS Section 02234 and may include up to 3 inch minus material with at least one fractured face. Larger material may be approved on a case-by-case basis, with at least one fractured face.
  - II. A geotextile such as Mirafi 600X (or approved equal) shall be placed between the sub base and the subgrade.
- D. Compaction:
  - I. All street construction shall meet the minimum compaction requirements set forth in Section 1.4.2 of these Standards.





# APPENDIX A – OWNERSHIP TRANSFER LETTER

## Appendix A – Example Ownership Transfer Letter

City of Great Falls  
Engineering Division  
P.O. Box 5021  
Great Falls, MT 59403

Re: Name of project/building/subdivision

(I)(We), the undersigned property owner(s), do hereby certify that (I)(We) have caused to be designed, constructed and tested the required infrastructure improvements necessitated by the development of (NAME of project/subdivision) in accordance with the approved plans.

As a condition of this development, we dedicate the improvements to the City of Great Falls (City). These improvements include all improvements within the City right-of-way including streets; sidewalks; street lighting; storm sewer, sanitary sewer, and water distribution mains; and other associated appurtenances. Also included in the dedication are water, sanitary sewer and storm drainage mains and appurtenances, and stormwater treatment facilities in easements or on dedicated land outside of rights-of-way. Specifically excluded from this dedication are stormwater facilities located outside of the City owned rights-of-way, which shall be owned and maintained by the property owners unless otherwise maintained by a stormwater service agreement (or HOA, POA, etc.).

(I)(We), further agree to the fullest extent permitted by law, (I)(We) shall fully indemnify, defend, and save City, its agents, representatives, employees, and officers harmless from and against any and all claims, actions, costs, fees, losses, liabilities or damages of whatever kind or nature arising from or related to the infrastructure improvements subject to this Agreement or work of any subcontractor or supplier.

Dated this \_\_\_\_\_ day of \_\_\_\_\_, 20\_\_.

(Acknowledged and notarized signatures of all  
record owners of developed property)

# APPENDIX B – DRIVEWAY APPLICATION

CITY OF GREAT FALLS  
 PLANNING & COMMUNITY DEVELOPMENT DEPT.  
 P.O. BOX 5021, GREAT FALLS, MT, 59403-5021  
 406.455.8431 • WWW.GREATFALLSMT.NET

## APPROACH/CURB CUT APPLICATION

This application is for a request to review a submittal for the construction of, or renovation of a approach and/or curb cut. To submit an application for pre-bid approval the applicant shall submit this form to Public Works Engineering. To submit an application for a permit a contractor shall submit drawings of plans and all supporting documents to Planning & Community Development Department for review.

APPROACH                       CURB CUT                       APPROACH/CURB CUT

**Property Address:**

**Contractor:**

**Contractor Phone:**

**Email:**

**Owner's Name :**

**Phone:**

**Email:**

### APPROACH CONSTRUCTION REQUIREMENTS

- 1) Approach construction within the public right-of-way shall be approved by the Great Falls City Engineer or designee prior to construction.
- 2) At an intersecting street or highway, the dimension measured along the edge of the traveled way to provide adequate corner clearance shall be measured a minimum distance of ten (10) feet from the intersecting property line to the nearest edge of the approach except at intersections where there are traffic signals, the nearside clearance shall be two (2) or more times this distance.
- 3) All approach construction shall be in conformance with the Standards and General Provisions for Design and Construction for Great Falls, Montana. The basic construction requirements are as follows:
  - A) Existing barrier, damaged, or nonconforming curb at the approach must be replaced with drive over type curb.
  - B) Approach approaches between the curbing and property lie must be constructed with concrete. See detail 5-10A, 5-10B, 5-10D, or 5-10E City of Great Falls Standards for Design and Construction.
  - C) All construction shall meet ADA requirements. If existing sidewalk does not meet ADA requirements Contractor shall install a landing & a sacrificial square of concrete between the new construction and the existing sidewalk.
- 4) Approach construction within the City right-of way must be performed by a bonded and insured contractor. ACI Certification is required for placing and finishing of concrete in the right-of-way.
- 5) Prior to beginning construction, a complete Application for Approach Construction shall be submitted to the City of Great Falls Planning and Community Development Department and all applicable permits shall be obtained.

### PLAN SUBMITTAL PROCESS (FOR BIDS)

- 1) The applicant shall submit an application with a site sketch to the Engineering Division for review.
- 2) The Engineering Division will respond within ten (10) working days with an approval or disapproval.
- 3) If the application is approved and the project moves forward, a contractor shall submit this approved application to Planning and Community Development; secure all permits; and pay all permit fees before construction may proceed.
- 4) If the application is disapproved the specific reasons will be given. An appeal process is available through the Planning and Community Development Department.

### PLAN SUBMITTAL PROCESS (PURCHASING PERMITS)

- 1) The contractor must submit a completed application with a site sketch to the Planning and Community Development Department for review.
- 2) The Engineering Division will respond within ten (10) working days with an approval or disapproval.
- 3) If the application is approved and permits secured, construction may proceed.
- 4) If the application is disapproved the specific reasons will be given. An Appeal process is available through the Planning and Community Development Department.

SITE PLAN SKETCH

DECISION BLOCK

An approval is only intended for the general location and width of the approach.  
The Contractor is responsible to ensure that the new approach meets ADA and City requirements.

Approved: \_\_\_\_\_ Date: \_\_\_\_\_

Denied: \_\_\_\_\_ Date: \_\_\_\_\_

This application will be null and void if the approach construction approved by this application is not completed within six (6) months from the date of approval.

Comments: \_\_\_\_\_  
\_\_\_\_\_  
\_\_\_\_\_  
\_\_\_\_\_



# APPENDIX C – CHECK LIST & DEVIATION REQUEST

No.	YES	N/A	Deviation Requested	Design Criteria
2.1.1.A				MT State Plane - International Feet
2.1.1.B				NAVD 88 or City of Great Falls Datum
2.1.1.C				Contours
2.1.1.D				Alignment data
2.1.2				Title Sheets
2.1.3				Plan Sheets
2.1.4				Plan and Profile Sheets
2.1.5				Detail Sheets
2.1.6				Road and Drainage Plans
2.1.7				Drainage Facilities and Swales
2.1.8				Basin Maps
No.	YES	N/A	Deviation Requested	Project Submittals
3.1.1.A				Civil Plans
3.1.1.B.III.a				Project Manual or applicable specifications
3.1.1.B.III.b				Water Design Report
3.1.1.B.III.c				Sanitary Sewer Design Report
3.1.1.B.III.d				Storm Drainage Design Report
3.1.1.B.III.e				Traffic Impact Study
3.1.2				Resubmittals
3.3.1				Deviation Requests
No.	YES	N/A	Deviation Requested	Development Requirements
4.1.1.B				Roadway and utility extensions
4.1.1.B.II				Right-of-ways and easements
4.1.2				Utility Requirements
4.1.3				Utility easements

Project: \_\_\_\_\_  
Professional Engineer: \_\_\_\_\_  
License No.: \_\_\_\_\_  
Firm: \_\_\_\_\_  
Date: \_\_\_\_\_

MT Professional Engineer's Stamp



Deviation requests noted on this form shall be submitted for review and approval in accordance with Section 3.3 of the Design and Construction Standards. Deviations not individually approved, even if shown in the approved plans, specifications, or reports, are not approved.



Project: \_\_\_\_\_

Firm: \_\_\_\_\_

Date: \_\_\_\_\_

No.	YES	N/A	Deviation Requested	Water System
5.1.1.A				Professional Stamp
5.1.1.B				MDEQ Circular 1 Requirements
5.1.1.C				Fire flow tests
5.1.3.A-B				Horizontal and vertical offsets
5.2.1.A				Water pipe size
5.2.1.B				Water pipe locations
5.2.1.C				Pipe materials
5.2.2.A				Valve sizes and types
5.2.2.B				Valve locations
5.2.3				Valve box materials
5.2.4				Fire hydrant
5.2.11.A				Water service general requirements
5.2.11.B				Water service construction
5.2.11.C				Water service locations
5.2.11.D				Water service sizes
5.2.12				Service saddle materials
5.2.13-14				Corp. and curb stop materials
5.2.15				Curb box materials
5.2.16				Entrance Valve and Backflow Assembly
5.2.17				Tapping Saddles
5.2.18				Couplings
5.2.20				Pipe Bedding
5.2.21				Warning tape
5.2.22				Tracer wire
5.2.23				Marker post materials

Deviation requests noted on this form shall be submitted for review and approval in accordance with Section 3.3 of the Design and Construction Standards. Deviations not individually approved, even if shown in the approved plans, specifications, or reports, are not approved.

Project: \_\_\_\_\_  
 Firm: \_\_\_\_\_  
 Date: \_\_\_\_\_

No.	YES	N/A	Deviation Requested	Sanitary Sewer System
6.1.1.A				MT PE Stamp and overall plan at buildout
6.1.1.B				MDEQ Circular 2
6.1.1.C				Sanitary Sewer Facility Plan design criteria
6.1.1.D				Over sizing
6.1.1.F				Existing sewer system analysis
6.1.1.G				Existing or proposed lift station data
6.1.2				General construction standards
6.1.3				Usage restrictions
6.1.4				Sulfide generation analysis
6.1.5				Locations
6.1.6				Offsets
6.2.1				Gravity main sizing and velocities
6.2.2				Sewer force mains
6.2.2.G				Private sewer force line connected at manhole
6.2.3.A				General sewer service requirements
6.2.3.C-F				Sewer service construction standards
6.2.3.G				Force sewer service line
6.2.3.H				Sewer service line materials
6.2.3.I				Sewer taps
6.2.3.J-M				Misc. sewer service items
6.2.4				Sewer pipe bedding
6.2.5				Detectable warning tape
6.2.6				Marker posts
6.3.1				Manhole design
6.3.2				Manhole construction
6.3.3				Manhole damp-proofing
6.4.1				Lift station design
6.4.2				Lift station construction
6.5.1				Grease traps and interceptors
6.5.2				Grease trap design and construction standards
6.5.3				Grease interceptors design and construction standards
6.5.4				Sand, oil interceptors
6.5.5				SOI design and construction standards

Deviation requests noted on this form shall be submitted for review and approval in accordance with Section 3.3 of the Design and Construction Standards. Deviations not individually approved, even if shown in the approved plans, specifications, or reports, are not approved.

Project: \_\_\_\_\_  
 Firm: \_\_\_\_\_  
 Date: \_\_\_\_\_

No.	YES	N/A	Deviation Requested	Transportation System
8.1.1				MUTCD, AASHTO guidelines, OCCGF, MT PE stamp
8.1.2				TIA requirements
8.1.3				Intersections
8.1.4				Dead-end streets
8.1.5				Sight distance
8.1.6				Local, collector, and arterial streets
8.1.7				Signs
8.1.8				Sidewalks
8.1.9				Boulevards/ open space
8.1.10				Shared use paths
8.1.11				On-street parking
8.1.12				Driveways
8.1.13				Placement of utilities
8.1.14				Traffic calming devices
8.1.15				Guardrails
8.1.16				Pavement design
8.1.17				Back slope and fill slope
8.2.1.A				MPWSS and Standards
8.2.1.B				MT PE
8.2.2.A				Asphalt material
8.2.2.B				Street sub base material
8.2.2.C				Crushed base course material
8.2.2.D				Compaction

Deviation requests noted on this form shall be submitted for review and approval in accordance with Section 3.3 of the Design and Construction Standards. Deviations not individually approved, even if shown in the approved plans, specifications, or reports, are not approved.



# APPENDIX D – LOW PRESSURE GRINDER PUMP SYSTEMS

## **SEWER DESIGN STANDARDS - LOW PRESSURE SEWER/GRINDER PUMP SYSTEMS**

### **General.**

- 1) A grinder pump and pressure sewer system is to be considered as an alternative for providing sewer service for a site, only if the site cannot be serviced by conventional gravity systems (including pumping stations).
- 2) Pressure sewer system is defined as an area to be serviced by more than a single grinder pump.
- 3) The City of Great Falls considers all Grinder Low Pressure/Grinder Pump Systems as private systems that are owned, operated and maintained by an entity such as an Owners Association. The formation of an Association with a System Operating & Maintenance Agreement is a City requirement of approval of such sewer system.
- 4) All systems shall comply with all applicable State of Montana standards and regulations.

### **Design Requirements.**

- 1) Grinder pumps used in pressure sewer systems for residential areas can only be the ones that have been previously approved or ones that may be subject to approval by the City of Great Falls for systems applications. Determine the type and model of the pump suitable for the system.
- 2) All pump types and models are to be the same in a single pressure sewer system unless otherwise approved by the City of Great Falls.
- 3) Primary design parameters to be considered are the number of pumps under simultaneous operation, flow velocities in pressure sewer piping, and limiting the operating head at a pump. Consider the following guidelines in defining these parameters:
  - a) Number of pumps under simultaneous operation.
    - i. Semi-positive displacement pump systems shall be designed in accordance with the Manufacture's recommended specifications and design standards and shall conform to the maximum number of simultaneously operating pumps.
    - ii. Centrifugal pump systems shall be designed in accordance with the Manufacture's recommended specifications and design standards and be sized so that the pumps under simultaneous operation shall be able to discharge the peak flow generated by the dwelling units located upstream of any point in the pressure sewer system under consideration.

- iii. For centrifugal pumps having a nominal discharge rate relatively close to that of an Environmental 1 (E/1) Pump, the maximum number of simultaneously operating pumps developed for E/1 pump systems may be used.

b) Flow velocities.

- i. Size a system for the maximum number of pumps that may be expected to operate under the full development stage, thereby generating the highest flow velocities and pumping head. Also consider in the design system hydraulics during the initial stage when a fewer number of pumps are expected to operate and lower velocities may be expected.
- ii. The minimum flow velocity should be approximately three (3) fps under simultaneous pump operating conditions, except for piping servicing one to two dwelling units where a two (2) fps minimum velocity shall be used. A three (3) fps minimum velocity criteria is required for pressure sewer profiles which have multiple high points and low points.
- iii. The maximum velocity shall be approximately seven (7) fps under simultaneous pump operating conditions.

c) Operating head at a pump.

- i. Maximum pumping head for system design to be ninety (90%) percent of the manufacturer's pump performance curve.
- ii. Design a centrifugal pump not to operate at above ninety (90%) percent of its shut off head and at or below its cut off point. The shut off head is the head at zero pump discharge; the cut-off point is a point on the pump curve where discharge head decreases abruptly with a small incremental flow.

- 5) Size a pressure sewer system and develop alternative designs such that the above criteria can be met during the full development stage and the initial stage as well.

6) System Design

a) Pumps

- i. With the selected maximum number of grinder pumps in simultaneous operation, design the piping system and submit all calculations, using the following design methods.
- ii. For semi-positive displacement pump systems use the E/1 Design Handbook for Pressure Sewer Systems or other pump manufacture's design information. Computerized design may be used for complex systems to give better accuracy in hydraulic calculations.
- iii. For centrifugal pump systems, a number of branches should be used to represent the piping layout similar to the design of semi-positive displacement pump systems. The

peak flow generated by all dwelling units in a branch shall be estimated. Locations of the pumps shall be designated and computer designs shall be used for analyzing system hydraulics during simultaneous pump operation.

- iv. Pumps located at the most remotest part of a system, farthest from the point of discharge to gravity system, and pumps located at the lowest elevations in a system must be considered in pump selection for simultaneous operation.
- v. In computing the static head, base the pump elevation on the developer's proposed elevation at which the grinder pump will be installed.

b. Pipe

- i. Minimum Pipe Size 1-1/4-inch diameter, Maximum Pipe Size 4-inch pipe diameter.
- ii. Allowable pipe material, SDR-21 PVC pipe and/or SDR-11 HDPE pipe. PVC pipe is generally installed in open-cut trench and HDPE pipe can be installed in open-cut trench or by horizontal directional drilling.
- iii. Use Hazen-Williams (HW) friction coefficient of one hundred forty (140) for calculating head losses through piping. Consider head losses through fittings and bends and other minor losses when calculating the total dynamic head.
- iv. Use sound engineering and hydraulic principles in design and analysis. Consider various scenarios of pipe sizes, system layout, and pump operation to arrive at an optimum design. Use of computer analysis enables checking for minimum and maximum flow velocities and pump discharge head under various operating scenarios.
- v. Uphill pumping is preferred in a pressure sewer system where the point of discharge to gravity system is at a higher elevation than the rest of the system, so as to maintain positive pressure throughout the system. Eliminate vertical piping alignment that may be conducive to siphoning at high points or gravity drain/air binding in downhill pumping conditions. Ideally, high points and low points are to be avoided and a continuously rising pressure sewer profile toward the point of gravity discharge is to be designed. Place pressure sewer air vacuum and air release valves at all high points in a system, if the high point cannot be eliminated.
- vi. PVC and/or HDPE piping is allowed, the nominal pipe diameters called for on the drawings may be different depending on the material. HDPE may be installed by horizontal directional drilling.
- vii. Joints and thrust restraint. PVC gasketed integral bell and spigot joints or bell by bell gasketed couplings shall be restrained mechanically and/or using concrete thrust blocks. PVC solvent weld shall be joined together using solvent weld couplings or integral solvent weld bell and spigot joints. HDPE pipe is generally a continuous pipe from a



long coil or lengths of pipe and fittings joined by thermal butt-fusion, electrofusion, or by special mechanical couplings. Joints for all HDPE pipe that is to be installed by horizontal directional drilling will be butt-fused. HDPE has a very high coefficient of thermal expansion/contraction.

c. Horizontal and Vertical Alignment, Depth, Clearances.

- i. Minimum depth of pipe is 6.5 feet below the ground elevation.
- ii. Minimum horizontal clearance with domestic (drinking) water mains and service line pipes is 10.0 feet.
- iii. Minimum vertical clearance with domestic (drinking) water mains and service lines is 18 inches.
- iv. Avoid 90 degree bends in the pipeline alignment
- v. Design the piping layout to minimize the total piping length.
- vi. To install HDPE pipe by horizontal directional drilling construction areas will be required at one end of the operation for layout and fusing pipe lengths to be pulled unless coils are used, and at the other end to set up and operate the drilling/pulling machine and drilling fluid storage tank and waste fluid storage. The amount of area required depends on the specific equipment used. Generally, sufficient area will be available in the normal right-of-way and construction strip used in the pipeline design. Verify that adequate space is available in the right-of-way and construction strip limits.
- vii. For minimum radius of curvature for PVC pressure sewer pipe, see Table below. Minimum radius of curvature for HDPE pipe installed in open-cut trench is forty (40) times the outside pipe diameter. Minimum radius of curvature for directionally drilled HDPE is dependent on allowable radius of curvature of Contractors' drilling rods. For design purposes, this can be assumed to be forty (40) feet. Radius of curvature at low points should be maximized.

**Minimum Curve Radius for PVC Pressure Sewers**

Pipe Size	Minimum Radius
1-1/4-inch to 1-1/2-inch	60 feet
2-inch	70 feet
2-1/2-inch	100 feet
3-inch	90 feet
4-inch	130 feet

d. Hydrogen Sulfide (H<sub>2</sub>S) Generation and Release Analysis and System Design.

- i. Perform the analysis for the proposed design to determine the potential for hydrogen sulfide generation.
- ii. Design the piping layout to minimize the total piping lengths and pipe sizes within the constraints of the hydraulic design criteria, so as to minimize sewage detention time in the system. Avoid downhill pumping conditions with a high point above the transition manholes, which will potentially cause the release and accumulation of hydrogen sulfide gas at the high points.
- iii. The discharge of sewage from a pressure sewer into a gravity sewer can potentially generate odor and the release of hydrogen sulfide at the transition manhole and in the downstream gravity sewer. Turbulence at the connection manhole should be minimized. Consider the corrosive effects of hydrogen sulfide in the design and selection of gravity sewer pipe material downstream of the connection manhole

### **Appurtenances and Structures.**

- 1) Each service line lateral shall be connected to the trunk force main using approved tapping saddles and corporation stops. Each service lateral shall also be equipped with a lateral assembly including compression adapters, curb shut off valve and check valve all located in an accessible vault structure with the public right-of-way boulevard area.
- 2) Install Flushing Connections at a minimum of every four hundred (400) feet in the system, or at dead ends. Flushing connections shall be freeze proof and access lids shall be rated for expected external loading.
- 3) Air release valves shall be included at any high points in system.
- 4) Connect the pressure sewer with the gravity sewer at a manhole on the gravity system.

#### a. Coating Specification:

##### i. Referenced standards and Specifications:

1. SP 6 Commercial Blast Cleaning
2. SP10 Near White Blast Cleaning
3. SP 13 Surface Preparation of Concrete

Materials: Interior Damp Proofing: Provide a two coat, Perma-shield MCU coating product, Themec 446 hydrophobic aromatic polyurethane, or approved equal.

Epoxy Modified Mortar: Provide epoxy modified “skim coat” mortar for

concrete patching, filling voids and holes. Provide Tnemec Mortar Clad Series 218 or approved equal.

**Surface Preparation Execution:**

All interior concrete walls, cover, floor and all other expose interior surfaces will require the interior damp proofing. All interior surfaces to be coated shall be clean and dry. All dirt, dust, sand, grit, mud, oil, grease and other foreign matter shall be removed. Prepare all interior surfaces to be coated per Steel Structures Painting Council Specification SP 13 or blast cleaning SP 6.

**Application Execution:**

Apply the specified epoxy modified mortar skim coat to all interior surfaces per manufacturer's application instructions. Patch and fill voids and holes ¼" – ½" in depth. Apply skim cost covering 100% of all concrete surfaces areas at 1/16" – ¼" spread rate.

The interior coating shall be brush, rolled, or sprayed in two coats, 8-10 dry mil thickness per coat, 16-20 dry mil total thickness. Concrete surfaces shall be cured and dry prior to coating.

**Curing:**

Curing shall adhere to manufacture's curing and drying schedule. Coatings must be fully cured before placing low pressure/grinder pump system into service.

**b). Connection Point:**

i. Pressure sewer shall enter manhole at 2/3 depth elevation of the gravity sewer pipe.

5) Include locator wire and stations on all installations including laterals. Locator specifications can be found under the City's water system standards.

**Pressure Testing**

1) All pressure mains and laterals shall be pressure hydrostatically tested after partial backfilling and are fully charged. The hydrostatic pressure shall be 150 percent of the maximum operating pressure. The duration of each test shall be 2 hours. Allowable leakage will be in accordance with AWWA C-600 or determined by the formula  $L = 0.000083(D)(S)$  where L is the allowable leakage in gallon per hour, S is the length of pipe under test in feet and D is the pipe diameter in inches.



**APPENDIX E – ADDITIONAL  
INFRASTRUCTURE REVIEW FEE  
GUIDANCE AND EXAMPLES**

# Appendix E – Additional Infrastructure Review Fee Guidance and Examples

## Delivering the Infrastructure Review Fee

The first half of the fee is due at plan submittal and is to be based on an accompanying engineer's cost estimate prepared by a licensed professional engineer with a schedule of values representing the unit prices and quantities necessary to complete the work. Due to construction cost escalation since 2020, the infrastructure cost in the fee equation shall be fifty percent (50%) of the total engineer's cost estimate. The Engineering Division will continue to monitor the fee and make adjustments via future resolution as needed. It is recommended that the Engineering Division is contacted at (406) 771-1258 to verify the cost estimate and fee amount prior to submittal. The first half of the fee is due by check, credit card payments are not allowed, made out to "City of Great Falls" and "Attn: Engineering" in the memo line and is to be mailed or hand delivered with the plan application to the Planning and Community Development Department:

Planning & Community Development  
2 Park Dr S #112  
PO Box 5021  
Great Falls, MT 59403

Alternatively, the first half check may be mailed or hand delivered directly to the Public Works Engineering Division:

Attn: Engineering  
1025 25<sup>th</sup> Ave NE  
PO Box 5021  
Great Falls, MT 59403

The second half of the fee is due prior to scheduling Pre-Construction meeting and is to be based on a revised schedule of values representing the unit prices from the selected contractor's bid. The second half of the Fee shall be calculated by the fee equation where the infrastructure cost shall be fifty percent (50%) of the total bid cost, and then subtracting the first half amount paid at the plan submittal. The Engineering Division shall review the second half fee calculation, selected contractor's schedule of values, and other necessary construction cost documents prior to submitting the second half of the fee. The Second half of the fee is due by check, credit card payments are not allowed, made out to "City of Great Falls" with "Attn: Engineering" in the memo line and is to be mailed or hand delivered to the Planning & Community Development Department or the Engineering Division at the addresses noted above.

## Engineer's Cost Estimate for Public Works Infrastructure

The cost estimate is to be composed of a schedule of values that represents the comprehensive construction cost of the infrastructure being dedicated to the City. This includes, but is not limited to all necessary materials and work to install Public Works

Department owned and maintained water mains, sewer mains, storm mains, streets, and alleys. In general, the engineer composing the schedule of values may use line items and unit of measurements of their choice that best describe the work and materials necessary to construct the Public Works infrastructure. Line items and unit of measurements on the schedule of values may or may not match the form of those described in the MPWSS. The following lists discuss items to include and exclude in the cost estimate:

#### General Exclusions

- Exclude the following: Division 0 and Division 1 items such as mobilization, bonding, traffic control, and other general conditions work; “soft” costs, administrative costs, permit fees, professional services such as engineering design and construction or surveying services, inspection, engineering oversight, contingencies, SWPPP efforts, all sidewalks, park improvements, public signage, striping, and street lighting facilities.

#### City Participation in Oversizing and Off-site Improvements

- Capital improvements costs associated with the extension of Public Works Infrastructure necessary to serve a new development are typically financed and paid for by the developer per the City Extension of Services Plan. If the development project includes an agreement with the City to participate in cost sharing of oversizing of infrastructure to serve other areas located outside the development, or if cost of necessary off-site improvements are being shared by the City, then the Infrastructure Review Fee shall not include the City’s share of the cost for oversizing or off-site improvements.

#### Water

- Include the following items if being dedicated to the City Public Works Department for ownership and maintenance: demolition or adjusting of existing public water utility infrastructure, pumping stations, mains, fittings, valves, valve boxes, hydrant leads, hydrants, blow off valves, mainline tapping sleeves and valves, water valve manholes and vaults, connection to existing mains, utility crossings, trench excavation and backfill, pipe bedding, import trench backfill, surface restoration (if surface is publicly owned and maintained), polyethylene encasement (poly wrap), insulation, wax tape system, test taps, disinfection, flushing, and testing, main gaskets, main joints and joint restraints, thrust blocks, warning tape, tracer wire, main marker posts, and other water system appurtenances considered to be owned and maintained by the Public Works Department.
- Exclude the following items considered to be privately owned and maintained: demolition or adjusting of existing private water utility infrastructure, service lines (City policy is that water service lines and appurtenances from the main to the meter or building are privately owned and maintained), service saddles, service tapping sleeves and valves, service trenching and excavation, service valves and boxes, meter pits, entrance and backflow assemblies, and any other service line appurtenances, private mains, private hydrants, private meters, and other water system appurtenances considered to be privately owned and maintained.

## Sewer

- Include the following items if being dedicated to the City Public Works Department for ownership and maintenance: demolition or adjusting of existing public sewer utility infrastructure, mains, force mains, manholes, fittings, trench excavation and backfill, pipe bedding, import trench backfill, surface restoration (if surface is publicly owned and maintained), lift stations, sewer main valves, tracer wire, detectable warning tape, polyethylene wrap, main gaskets, insulation, testing, main joints and gaskets, utility crossings, main marker posts, and other sewer system appurtenances considered to be owned and maintained by the Public Works Department.
- Exclude the following items considered to be privately owned and maintained: demolition or adjusting of existing private sewer utility infrastructure, service lines (City policy is that sewer service lines and appurtenances from the main to the building are privately owned and maintained), service wyes and connections to mains, force service lines, private grinder pumps systems, grease traps and interceptors, sand oil separators, and other sewer system appurtenances considered to be privately owned and maintained

## Storm

- Include the following items if being dedicated to the City Public Works Department for ownership and maintenance: demolition or adjusting of existing public storm utility infrastructure, mains, manholes, vaults, inlets, catch basins, inlet covers and grates, fittings, trench excavation and backfill, pipe bedding, import trench backfill, surface restoration (if surface is publicly owned and maintained), storm main valves, storm treatment structures, detectable warning tape, polyethylene wrap, main gaskets, acceptance testing, main joints and gaskets, utility crossings, detention ponds, public pond sodding and final stabilization, culverts, headwalls, outfall structures, sidewalk chases, swales and other overland conveyance facilities, marker posts, and other storm system appurtenances considered to be owned and maintained by the Public Works Department.
- Exclude the following items considered to be privately owned and maintained: demolition or adjusting of existing private storm utility infrastructure, private storm systems, service lines (City policy is that the storm service lines and appurtenances from the main to the private system are privately owned and maintained), service connections to mains, private ponds, private culverts, private conveyance facilities, private treatment structures, and other storm system appurtenances considered to be privately owned and maintained

## Streets and Alleys

- Include the following items if the roadway is being dedicated to the City Public Works Department for ownership and maintenance within a Right of Way: demolition or adjusting of existing public street infrastructure, topsoil stripping, rough or mass grading; street excavation, backfill and compaction; geotextile fabric, sub base course, crushed base course, asphalt prime and/or tack coat, asphalt



seal coat, construction seal, asphalt concrete pavement, Portland cement concrete pavement, concrete curb and gutter, valley gutters, curb turn fillets, alley approaches, street monuments, traffic signals, and other street system appurtenances considered to be owned and maintained by the Public Works Department.

- Exclude the following items considered to be privately owned and maintained or as noted: demolition or adjusting of existing private street infrastructure; relocating or removing utility poles, all street signs and mailboxes; all sidewalks and crosswalk ramps; private sidewalk, parking lots, curb, and gutter; private pavement markings and markers; private driveways or approaches, traffic signals, street lighting and appurtenances, dry utility conduits; dry utilities such as power, gas, or communication lines; boulevard seeding or landscaping, other street system appurtenances considered to be privately owned and maintained, and other items as noted by the Engineering Division.

### Example 1 – Subdivision

A developer wishes to extend public works infrastructure for a new subdivision large enough to include the installation of water mains, sewer mains, storm mains, manholes, inlets, culverts, paved streets, concrete curb and gutter, and all necessary valves, parts, assemblies, and other utility appurtenances. The example schedule of values below consists of the line items, quantities, unit prices, and total cost necessary to build privately installed public infrastructure that will be dedicated to the City, unit prices are for educational purposes only:

### **Example 1 - Schedule of Values**

Item #	Item Description	Qty	unit	Unit Price	Total Cost
	<b>Water</b>				
1101	8"x8" Tee	1	ea	\$500.00	\$500.00
1102	8"x8" cross	1	ea	\$900.00	\$900.00
1103	8" Water Main	1,499	lf	\$50.00	\$74,950.00
1104	8" Valve	6	ea	\$1,600.00	\$9,600.00
1105	Blow Off Assembly	3	ea	\$2,000.00	\$6,000.00
1106	Fire Hydrant Assembly	6	ea	\$5,500.00	\$33,000.00
1107	Connect to Existing 12" Main with 8" WM includes valve	2	ea	\$4,000.00	\$8,000.00
1108	Connect to Existing 24" Main with 8" WM includes valve	1	ea	\$5,000.00	\$5,000.00
1109	Existing Utility Crossing	6	ea	\$1,000.00	\$6,000.00
	<b>Sewer</b>				
1201	8" Sewer Main	1,193	lf	\$40.00	\$47,720.00
1202	10" Sewer Main	827	lf	\$50.00	\$41,350.00
1203	Standard Manhole 5' Depth	6	ea	\$2,500.00	\$15,000.00
1204	Extra Manhole Depth	25	lf	\$400.00	\$10,000.00
1205	Connect to existing manhole with core and boot	1	ea	\$4,000.00	\$4,000.00
1206	Existing Utility Crossing	7	ea	\$1,000.00	\$7,000.00

<b>Stormwater</b>					
1301	24" x 36" Curb Inlet	4	ea	\$3,500.00	\$14,000.00
1302	48" Storm Manhole	4	ea	\$3,500.00	\$14,000.00
1303	12" RCP Storm Drain	84	lf	\$20.00	\$1,680.00
1304	15" RCP Storm Drain	44	lf	\$30.00	\$1,320.00
1305	18" Culvert	374	lf	\$70.00	\$26,180.00
<b>Street &amp; Alley</b>					
1401	Topsoil Stripping 15" depth	3,862	cy	\$5.00	\$19,311.25
1402	Road Grading cut and fill on-site	2,344	cy	\$5.00	\$11,722.04
1403	Construct Road Subgrade	7,033	sy	\$1.50	\$10,549.83
1404	Geotextile Fabric	7,033	sy	\$3.00	\$21,099.67
1405	Crushed Road Base	1,172	cy	\$28.00	\$32,821.70
1406	Curb and Gutter	3,168	lf	\$17.00	\$53,856.00
1407	Asphalt Pavement - 4"	50,415	sf	\$2.00	\$100,830.00
<b>Total Construction Cost</b>					<b>\$576,390.49</b>
<b>Fifty Percent (50%) of Construction Cost</b>					<b>\$288,195.25</b>

Fee =  $3.3182 * ((\text{Infrastructure Cost})^{0.6593})$

$3.3182 * ((\$288,195.25)^{0.6593}) = \$13,196.97$

First half due at plan submittal =  $\$13,196.97 / 2 = \$6,598.48$

In this example, the revised construction cost based upon the bid unit prices came to be a total of \$650,000.00. Fifty percent (50%) of the total bid cost is \$325,000.00.

2nd half due prior to pre-con =  $3.3182 * ((\$325,000.00)^{0.6593}) - \$6,598.48 = \$7,686.75$

### Example 2 – Building Permit with Public Infrastructure Improvements

A developer has applied for a building permit that will require the removal and relocation of an existing fire hydrant. The property is already served by existing Public Works infrastructure and the location of the proposed driveway is in direct conflict with an existing fire hydrant. Because the project consists of modifying a hydrant owned and maintained by the Public Works Department, the Infrastructure Review Fee applies. The example schedule of values below consists of the line items, quantities, unit prices, and total cost necessary to build privately installed public infrastructure that will be dedicated to the City, unit prices are for educational purposes only:

### **Example 2 - Schedule of Values**

Item #	Item Description	Qty	unit	Unit Price	Total Cost
<b>Water</b>					
1101	Demo existing fire hydrant and cap w/ blind flange	1	ea	\$1,600.00	\$1,600.00
1102	8" x 6" Tapping sleeve with Valve	1	ea	\$500.00	\$500.00
1103	6" water main	20	lf	\$72.50	\$1,450.00
1104	Valve Box	1	ea	\$350.00	\$350.00
1105	Fire Hydrant Assembly	1	ea	\$6,000.00	\$6,000.00
1106	Surface Repair (within the R.O.W.)	15	sy	\$550.00	\$8,250.00

	<b>Total Construction Cost</b>				<b>\$18,150.00</b>
	<b>50% of Construction Cost</b>				<b>\$9,075.00</b>

$$\text{Fee} = 3.3182 * ((\text{Infrastructure Cost})^{0.6593})$$

$$3.3182 * ((\$9,075.00)^{0.6593}) = \$1,349.93$$

$$\text{First half due at plan submittal} = \$1,349.93 / 2 = \$674.96$$

In this example, the revised construction cost based upon the bid unit prices came to be a total of \$16,000.00. Fifty percent (50%) of the total bid cost is \$8,000.00

$$\text{2nd half due prior to pre-con} = 3.3182 * ((\$8,000.00)^{0.6593}) - \$674.96 = \$567.29$$

Note: the building permit review fee and the private stormwater review fee, if applicable, would be assessed separately and due at building permit letting.

### Example 3 – Stand Alone Public Infrastructure Improvements

A project on private property, not associated with a building permit, requires removal and replacement of a public storm main within a City easement. The design engineer has also recommended that the developer install a trench plug at the replaced main. Because the project consists of modifying a storm main owned and maintained by the Public Works Department, the Infrastructure Review Fee applies. The example schedule of values below consists of the line items, quantities, unit prices, and total cost necessary to build privately installed public infrastructure that will be dedicated to the City, unit prices are for educational purposes only:

#### **Example 3 - Schedule of Values**

Item #	Item Description	Qty	unit	Unit Price	Total Cost
	<b>Storm</b>				
1101	Demo existing 12" storm Drain	1	ls	\$15,000.00	\$15,000.00
1102	Trenching and Backfilling	160	cy	\$135.00	\$21,600.00
1103	Trench Plug	1	ea	\$2,000.00	\$2,000.00
1104	18" RCP Storm Drain Pipe	200	lf	\$75.00	\$15,000.00
1105	Connect 18" Storm Drain to existing Manhole	2	ea	\$2,000.00	\$4,000.00
1106	Type II Bedding	30	cy	\$35.00	\$1,050.00
	<b>Total Construction Cost</b>				<b>\$58,650.00</b>
	<b>50% of Construction Cost</b>				<b>\$29,325.00</b>

$$\text{Fee} = 3.3182 * ((\text{Infrastructure Cost})^{0.6593})$$

$$3.3182 * ((\$29,325.00)^{0.6593}) = \$2,925.18$$

$$\text{First half due at plan submittal} = \$2,925.18 / 2 = \$1,462.59$$

In this example, the revised construction cost based upon the bid unit prices came to be a total of \$60,000.00. Fifty percent (50%) of the total bid cost is \$30,000.00

$$\text{2nd half due prior to pre-con} = 3.3182 * ((\$30,000.00)^{0.6593}) - \$1,462.59 = \$1,506.81$$



# APPENDIX F – PRECONSTRUCTION MEETING DOCUMENTS

CITY OF GREAT FALLS  
**PRECONSTRUCTION MEETING CHECKLIST**

Engineering Division: 406-771-1258

Environmental Division: 406-727-8390

**Project Name:** \_\_\_\_\_

**Description of Work (water, sanitary sewer, storm sewer, streets):** \_\_\_\_\_

**Owner/Developer:** \_\_\_\_\_

**Engineer:** \_\_\_\_\_

**Contractor:** \_\_\_\_\_

The Applicant (or designated representative) is required to complete, fill out, and provide the applicable items on this checklist form. Coordination with the City Engineering office is required to ensure the required applicable items are provided prior to scheduling the preconstruction meeting. Paper and digital copies are required and may be delivered by e-mail to the City's project engineer. Email attachments may not exceed a combined size of 17 MB. If a required item is missing, the Engineering Office reserves the right to postpone the scheduling of the preconstruction meeting to after the missing items are provided.

CHECKLIST			
ITEM	APPLICABLE (Y/N)	DATE SUBMITTED	REMARKS
Final City Approved Plans and Specs			
DEQ Approved Plans and Specs			
DEQ Approval Letter			
*Inspection Certification Letter			
2nd Half of Infrastructure Review Fee			
Easement Documents			
Approved Submittals/Shop Drawings			
Completed Pre-Con Agenda (with billing information provided)			
Approved Erosion Control Plan or SWPPP			
Traffic Control Plan			
Copy of Maintenance Bond			
Copy of Contractor Insurance Certs.			
Other			

\*Letter certifying that the owner/developer will employ a Professional Engineer (typically CoGF Engineering Staff) to verify compliance with minimum construction standards throughout construction of all proposed CoGF infrastructure within the development and certify that the system was built in conformance with the plans and specifications approved by the reviewing authority (ARM 17.36.121).



Public Works Department – Engineering Division  
1025 25<sup>th</sup> Avenue Northeast  
PO Box 5021  
Great Falls, MT 59401  
Phone: 406-771-1258

**PUBLIC WORKS INFRASTRUCTURE  
PRECONSTRUCTION CONFERENCE AGENDA FORM  
(Contact Engineering for Office File Number)**

**Project Name and Office File Number** \_\_\_\_\_

**Date and Time** \_\_\_\_\_ **Meeting Location** PW-ENG Conf. Room

**1. Introductions.**

**2. Development Background Information and Review Status:**

**a. Development Location:**

A large, empty light blue rectangular box intended for providing details about the development location.

**b. Infrastructure Review Status (as applicable):**

\_\_\_\_\_ *Date of Montana Department of Environmental Quality  
approval of the municipal facilities*

\_\_\_\_\_ *Date of City of Great Falls approval of municipal facilities (with  
written fire marshal approval if necessary)*

**c. Permitting Status (as applicable):**

\_\_\_\_\_ *Date of DEQ Confirmation of Notice of Intent for Coverage  
MPDES Stormwater Discharge Associated with Construction  
Activity or CoGF approval of Erosion Control Plan (ECP).*

*SWPPP/ECP Administrator* \_\_\_\_\_

*Traffic Control Plan submittal date* \_\_\_\_\_

**d. ADDITIONAL PERMITS, check box below if applicable:**

- Fire line
- Water Service Line
- Sewer Service
- Right-of-way
- Sidewalk and/or Curb
- Driveway and/or Curb Cut
- MDT (Utility Encroachment, Utility Occupancy, Encroachment)
- Other \_\_\_\_\_

**e. Submittal Status (as applicable):**

- *Submit all engineer and contractor approved shop drawings, fab drawings,  
and other necessary submittals to City, check box below if applicable:*

- Water
- Storm Sewer
- Sanitary Sewer
- Streets, Driveways, Approaches, Sidewalk
- Soil Materials

**3. Development Representatives:**

- a. Developer:**            *name, phone,*  
   *email* \_\_\_\_\_
- b. General Contractor:** *name, phone,*  
   *email* \_\_\_\_\_
- c. Sub-Contractors:**    *name, phone,*  
   *email* \_\_\_\_\_  
   *name, phone,*  
   *email* \_\_\_\_\_



- d. **Engineer:**                    *name, phone,*  
   *email* \_\_\_\_\_
- e. **Surveyor:**                    *name, phone,*  
   *email* \_\_\_\_\_

**4. City of Great Falls Representatives**

- a. **Engineering Division:**    Admin desk (406) 771-1258  
     **City Engineer:**            Jesse Patton  
     **Project Engineer:**        \_\_\_\_\_  
     **Inspectors:**                \_\_\_\_\_
- b. **Utility Division:**         Dispatch (406) 771-8045  
     **Manager:**                  Jake McKenna  
     **Superintendent:**         Pat Habel
- c. **Street Division:**         Operations (406) 771-1401  
     **Manger:**                  Eric Boyd  
     **Superintendent:**         Dan Palagi  
     **Traffic Foreman:**         Austin Schultz
- d. **Environmental Division:**    Admin desk (406) 727-8390  
     **Manager:**                  Nate Beisch  
     **Stormwater Compliance Tech:** \_\_\_\_\_
- e. **City Water Plant Laboratory:**    Admin desk (406) 727-1325  
     **Water Quality Specialist:**    Brandi Nicholson or Mike Grison
- f. **City Planning/Community Development Department:**    Inspections & Permits (406) 455-8430  
     **Point of Contact:**         \_\_\_\_\_  
     **Building Official:**         Bruce Harman  
     **Plumbing Inspector:**       Ray Cook

**5. Project Schedule/Phasing**

**Public Water, Sewer, Storm, & Street Improvements:**

<b>State Date</b>	<b>Sewer:</b> _____
	<b>Water:</b> _____
	<b>Storm:</b> _____
	<b>Street:</b> _____
<b>End Date</b>	<b>Sewer:</b> _____
	<b>Water:</b> _____
	<b>Storm:</b> _____
	<b>Street</b> _____

**Contractor's Working Hours / Days:** \_\_\_\_\_

*Note: Please contact the engineering department (771-1258) to coordinate full time city inspection during installation of all public works infrastructure. If inspectable work is performed outside of M-F, 8-4:30, overtime rates will apply.*

**6. Requirements for Inspection, Testing, and Construction Management:**

- a. City Inspection Services:** *City full time inspection required for Public Water, Sewer, & Storm Improvements, including connection to public Storm System. **Note the Cost of Inspection and Testing is the Developer's Responsibility.***
  - Inspection Rate: \$66/hr - Overtime (outside of M-F 8-4:30): \$80/hr
  
- b. City Engineering Construction Oversight:** *City Engineering Division provides construction oversight of public works infrastructure and the cost is included in the infrastructure review fee. For projects which are not assessed an infrastructure review fee, City engineering construction management and miscellaneous services shall be assessed at \$108/hr. **Note the Cost of Construction Management and Miscellaneous Services is the Developer's Responsibility.***
  
- c. Testing:** *To be performed in accordance with City's Standards for Design and Construction, Montana Public Works Specifications (MPWSS), local, state, and federal requirements.*
  
- d. City Furnished Testing:**
  - *Field Density and Moisture for Pipe Bedding, Trench Backfill.*
  - *Field Video Inspection of sanitary sewer main. **Note the Cost of Videoing is the Contractor's or Developer's Responsibility.***

- *Field Sampling and Laboratory Bacteriological Testing of Water Mains and Fire Lines. Note the Cost of Testing is the Contractor's or Developer's Responsibility.*

**e. Developers or Contractor's Testing Responsibility:**

- *Provide necessary soil reports (proctors, gradations, etc.)*
- *All Field and Laboratory Testing for Asphalt Cement and Portland Cement Mix Design and Placement (for work being done within the right-of-way).*
- *Water Main and Service Line Pressure Tests and Disinfection.*
- *Testing that is not listed above.*

**7. Requirements for Coordination, Notifications, and Utility Locates:**

**a. City/Contractor/Engineer Coordination Items**

- *Inspection*
- *Operation of City Utilities performed by City personnel*
- *Laboratory and Field Testing Results*
- *Inspection Reports*

**b. Contractor Notification Responsibilities:**

- *Utility Service or Roadway Disruptions: 72 – hours advanced notification to City Project Engineer, Inspector, and Disrupted Customers*
- *Utility Operation, Tapping, Television: 48 hours advance, City Utility Division*
- *Water Sampling and Bact Testing: 48 hours advance, City Engineering Inspector and Water Plant Laboratory*
- *Water Services 2-inches and under require inspections through Planning and Community Development, coordinate permitting and inspections through them.*

**c. Utility Location:**

- *Contractor Responsibility (One Call 1-800-424-5555).*
- *Utilities (Gas, Electric, Communications, Others) Coordinate with respective companies.*

**8. Plans, Specifications, Construction Related Discussion:**

- *All construction to conform to City Standards for Design & Construction, MPWSS, and relevant local, state, and federal requirements*
- *Wax Tape system required on water system flanges and all bolts on mechanical and flanged joints, restraints, sleeves couplers, fittings and valves*
- *Leave gravel flush up to surface for city paving crews – then when the city crew is available have the contractor cut down gravel from flush to bottom of asphalt lift depth – use flowable fill if period of patch replacement extends through winter, flow fill up to flush with existing top of asphalt*
- *Asphalt patching in ROW to be completed by Street Division and billed to the Contractor or Developer, unless approved otherwise*

**9. Requirements for Final Inspection, Project Closeout, and Warranty:**

- **Project Completion Inspection:** *May include City, Developer, Engineer, and Contractor(s) after completion of all public improvements.*
- **Final Punch List:** *Punch List items to be corrected before City acceptance of improvements.*
- **As-Built Plans:** *Developer's Engineer to provide City with one set of As-Built Plans on Mylar.*
- **Warranty:** *2-year warranty on all public works infrastructure beginning at the date of substantial completion.*

**10. Billing Information**

- *Provide Billing contact information for City's Inspection Fees*

**Name:** \_\_\_\_\_  
**Address:** \_\_\_\_\_  
**Email:** \_\_\_\_\_  
**Phone:** \_\_\_\_\_

# CITY OF GREAT FALLS STANDARD DETAILS

**Details - Article 5****Drawing Number****Current Drawing  
Date**

Typical Monument Installation	5-01	2023
Standard Straight Curb	5-03	2023
Typical Barrier Integral Curb & Gutter	5-04	2023
Typical Mountable Integral Curb & Gutter	5-05	2023
Integral Curb and Gutter Details	5-06	2023
Standard Concrete Alley Apron- Grass back of curb	5-08A	2023
Standard Concrete Alley Apron- Sidewalk back of curb	5-08B	2023
Standard Concrete Alley Apron- City Jobs	5-08C	2023
Standard Concrete Alley Apron- City Jobs	5-08D	2023
Standard Detail for Asphalt or Gravel Paving of Public Alley	5-09	2023
Driveway - Sidewalk at curb	5-10A	2023
Driveway - Sidewalk not at curb	5-10B	2023
Curb and Sidewalk cross section	5-10C	2023
Driveway - Straight Curb sidewalk not at curb	5-10D	2023
Driveway - Downtown Decorative Stamp	5-10E	2023
Park Path Cross section	5-14	2023
Valley Gutter - w/ Double HC ramps	5-15A	2023
Valley Gutter - w/ Single HC ramp	5-15B	2023
Sidewalk drainage crossing gutter	5-16	2023
Handicap ramp at mid-block with boulevard sidewalk	5-17A	2023
Handicap ramp at mid-block with attached sidewalk	5-17B	2023
Handicap ramp at mid-block with adjacent sidewalk	5-17C	2023
Handicap ramp at mid-block w/ full width boulevard sidewalk	5-18	2023
Handicap ramp at center of corner	5-19	2023
Handicap ramps double at corner in boulevard areas	5-20	2023
Handicap ramps double at corner sidewalk at curb	5-21A	2023
Handicap ramps double at corner sidewalk at curb	5-21B	2023
Handicap ramps Double Central Business dist.	5-22	2023
Handicap ramps Double Old Boulevard area	5-24	2023
Trench Detail - Type 1	5-30	1987
Trench Detail - Type 2	5-31	2023
Trench Method of Payment	5-32	1987
Casing Detail	5-33	2023
Flowable Fill Trench Plug	5-34	2009
Trench Pavement Replacement	5-36	2023
Trace Wire - Hydrant Detail	5-38	2023
Gate Valve Detail	5-39	2023
Fire Hydrant Detail - City of Great Falls	5-40	2023
Fire Hydrant Replacement on exist. Hyd lead	5-41	2023
Fire Hydrant Guard (bollards)	5-42	2023
Thrust Blocking Details	5-43	2023
Water Service expansion loop	5-44	1987
Water Service replacement connections	5-45	2023

Water Service / Storm Drain Xing	5-45A	2023
Water Service / Storm Drain Xing	5-45B	2023
Water meter installation	5-46	1987
Water Service Entrance 4" and Larger Diameter	5-47	2023
Meter Pit - Residential	5-48	2023
Meter Vault - Large meters	5-49	2023
Irrigation Manhole - 1-1/2" meter and up	5-49A	2023
Sanitary sewer main at water main crossing	5-50	2023
Irrigation Service Detail	5-51	2019
Sewer Repair coupling	5-52	2023
Sewer Service connection in trench	5-53	2023
Sewer Service riser in trench	5-54	2023
Force Main Discharge into Existing Manhole	5-55	2023
Storm sewer inlet	5-60	2023
Storm sewer curb inlet apron - Type 1	5-61B	2023
Storm sewer curb inlet apron - Type 2	5-61C	2023
Storm sewer corner inlet apron	5-61D	2023
Sanitary Sewer Manhole ring & cover	5-63	2023
Sewer Manhole Short	5-64	2023
Sewer Manhole standard	5-65	2023
Manhole Connection - Over Existing Pipe	5-69	2023
Sample Port	5-70	2019
Typical Exterior Sand and Oil Separator	5-71	2019
Typical Exterior Grease Interceptor	5-75	2023
Typical Interior Grease Interceptor	5-76	2023
Standard MUTCD Type III Fixed Barricade	5-80	2023
Dead End - Warning Sign	5-81	2009
Branch Trimming	5-82	2021

OLYMPIC NO. 5680 MONUMENT BOX

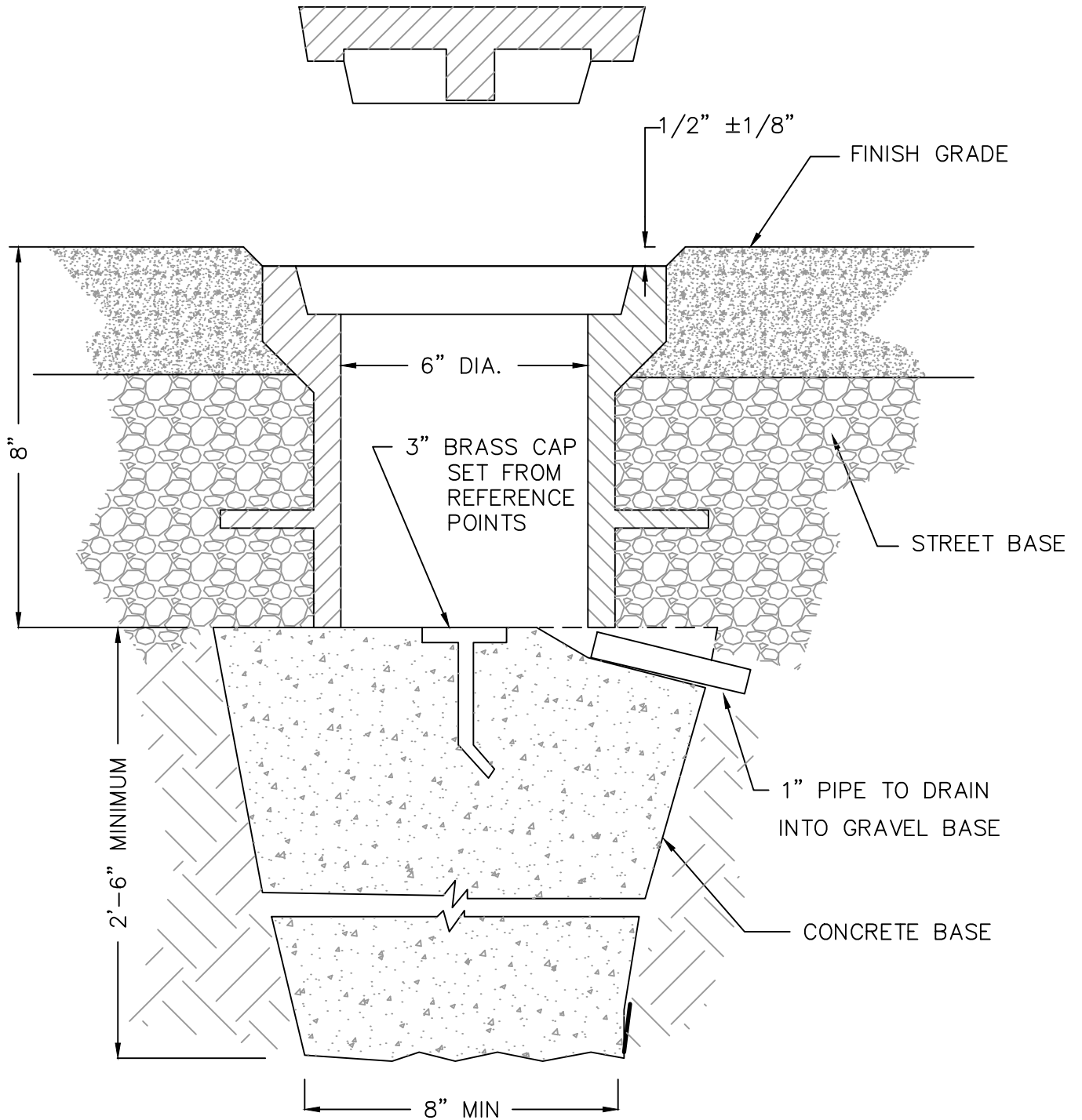

TYPICAL MONUMENT INSTALLATION



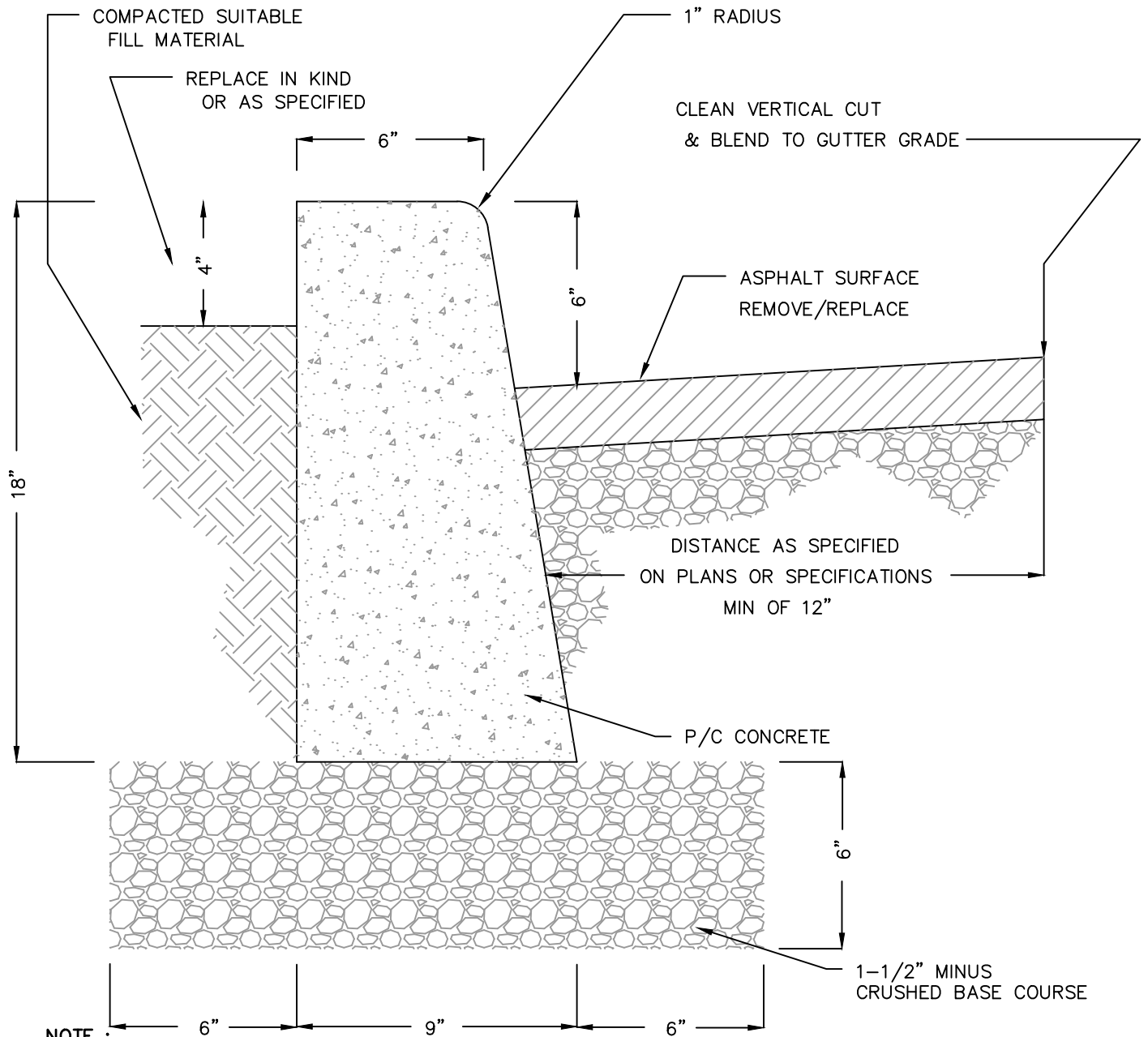

**NOTE :**

1. THE FACE OF THE CURB, WHERE CONTACTED BY PAVING SHALL BE THOROUGHLY PAINTED WITH BITUMINOUS MATERIAL ACCEPTABLE TO THE ENGINEER.
2. PLACE COMPACTED GRAVEL UNDER CURB AS REQUIRED ON PLANS OR IN SPECIFICATIONS.
3. ACI CERTIFICATION IS REQUIRED FOR PLACING AND FINISHING CONCRETE IN THE RIGHT-OF-WAY.

**STANDARD STRAIGHT CURB**

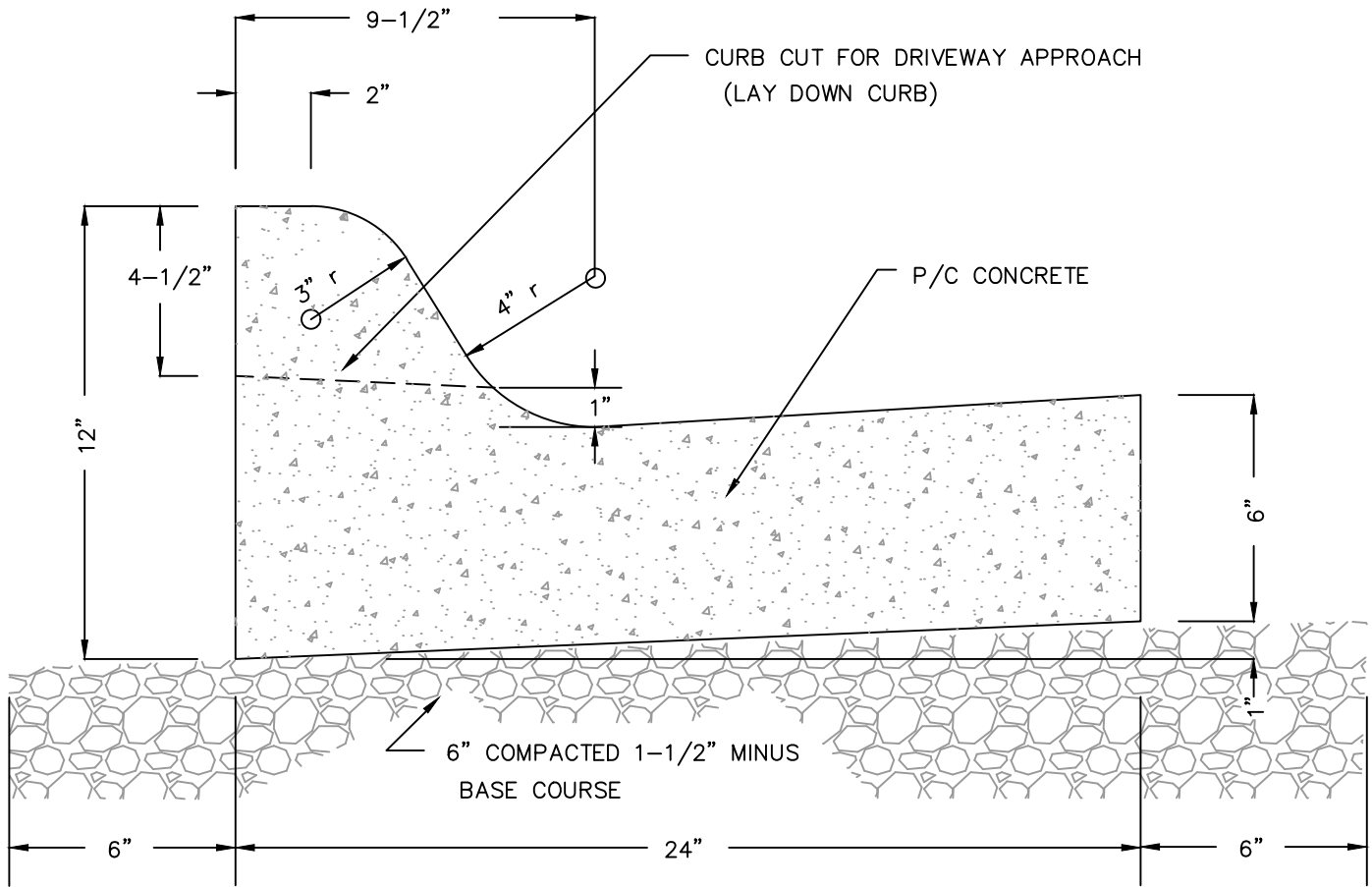

NOTES:

1. CURB & GUTTER SHALL HAVE A TOOLED CONTRACTION JOINT EVERY 10' AND BE SCORED A MIN. DEPTH OF 3/4"
2. CURB & GUTTER SHALL HAVE 1/2" EXPANSION JOINT AT P.C.'s, P.T.'s, CURB RETURNS, VERTICAL AND HORIZONTAL POINTS OF CURVATURE AND AT MAXIMUM OF 300' INTERVALS.
3. PLACE GRAVEL BASE COURSE AS REQUIRED IN SPECIFICATIONS.
4. ACI CERTIFICATION IS REQUIRED FOR PLACING AND FINISHING CONCRETE IN THE RIGHT-OF-WAY.

TYPICAL BARRIER INTEGRAL CURB & GUTTER

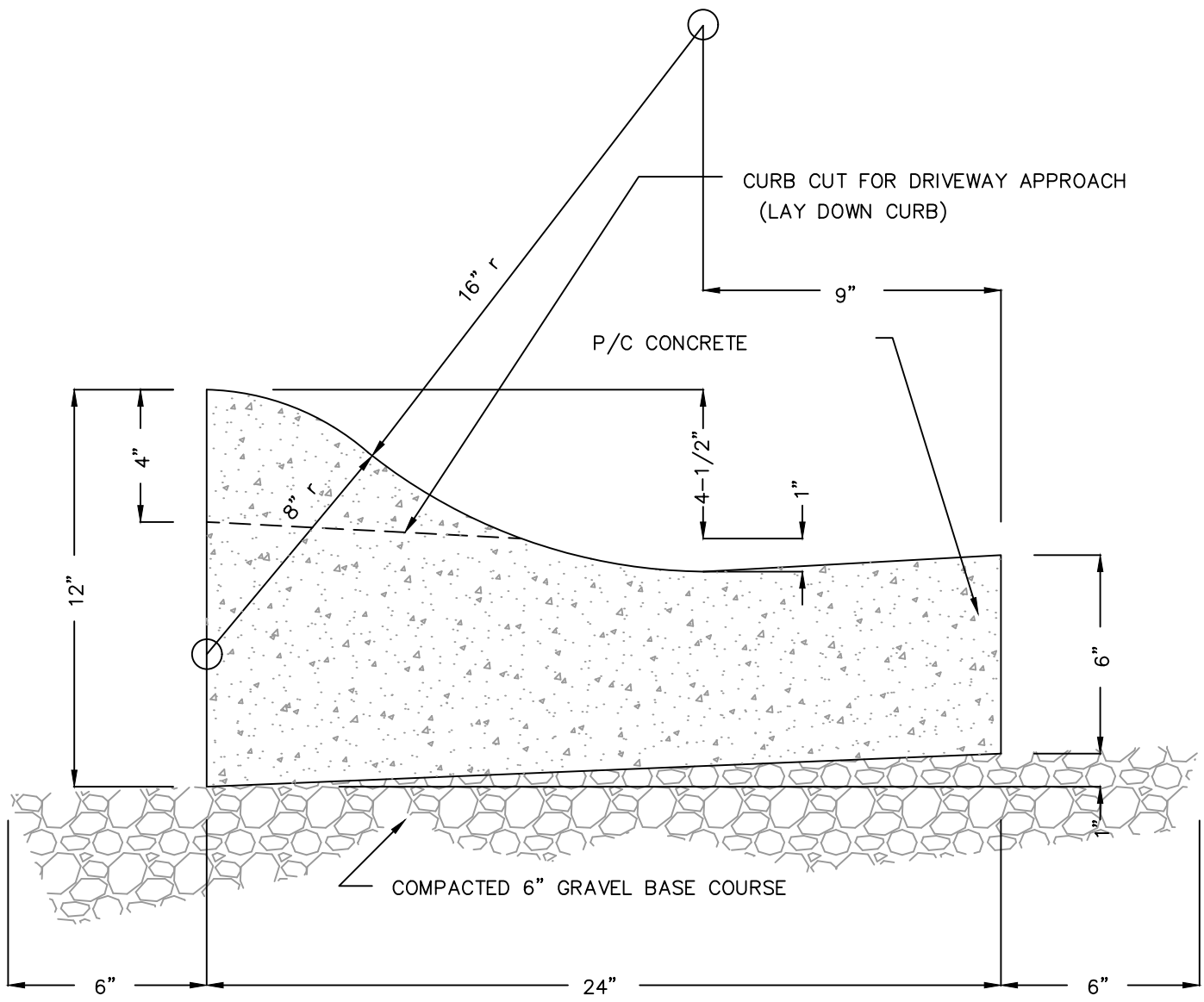

NOTES:

1. CURB & GUTTER SHALL HAVE A TOOLED CONTRACTION JOINT EVERY 10' AND BE SCORED A MIN. DEPTH OF 3/4".
2. CURB & GUTTER SHALL HAVE 1/2" EXPANSION JOINT AT P.C.'s, P.T.'s, CURB RETURNS, VERTICAL AND HORIZONTAL POINTS OF CURVATURE AND AT MAXIMUM OF 300' INTERVALS
3. PLACE GRAVEL BASE COURSE AS REQUIRED IN SPECIFICATIONS.
4. ACI CERTIFICATION IS REQUIRED FOR PLACING AND FINISHING CONCRETE IN THE RIGHT-OF-WAY.

TYPICAL MOUNTABLE INTEGRAL CURB & GUTTER

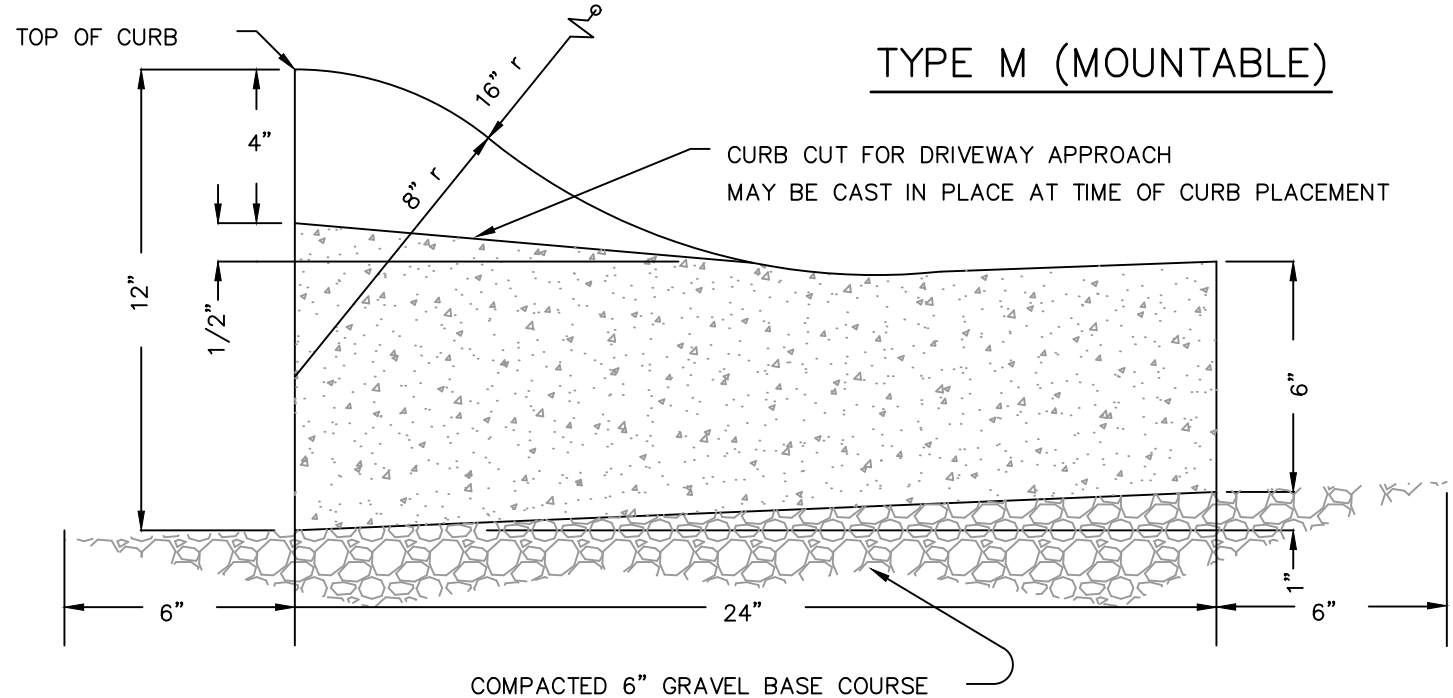
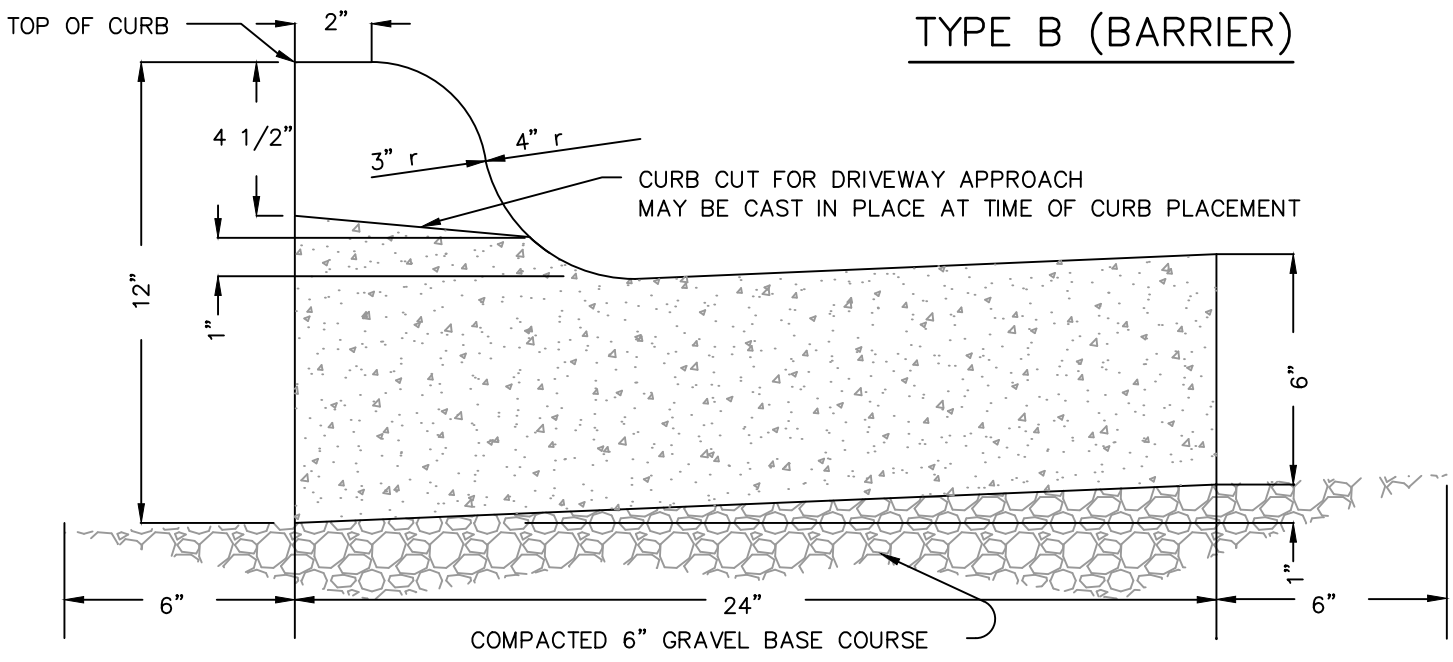

- NOTES:**
1. CURB & GUTTER SHALL HAVE A TOOLED CONTRACTION JOINT EVERY 10' AND BE SCORED A MIN. DEPTH OF 3/4".
  2. CURB & GUTTER SHALL HAVE 1/2" EXPANSION JOINT AT P.C.'s, P.T.'s, CURB RETURNS, VERTICAL AND HORIZONTAL POINTS OF CURVATURE AND AT MAXIMUM OF 300' INTERVALS.
  3. PLACE GRAVEL BASE COURSE AS REQUIRED IN SPECIFICATIONS.
  4. ACI CERTIFICATION IS REQUIRED FOR PLACING AND FINISHING CONCRETE IN THE RIGHT-OF-WAY.

**INTEGRAL CURB AND GUTTER DETAILS**

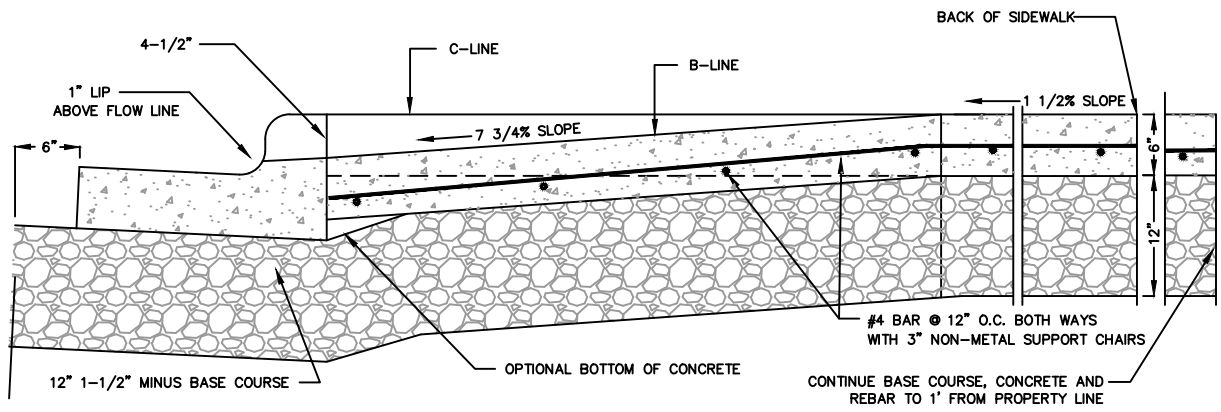
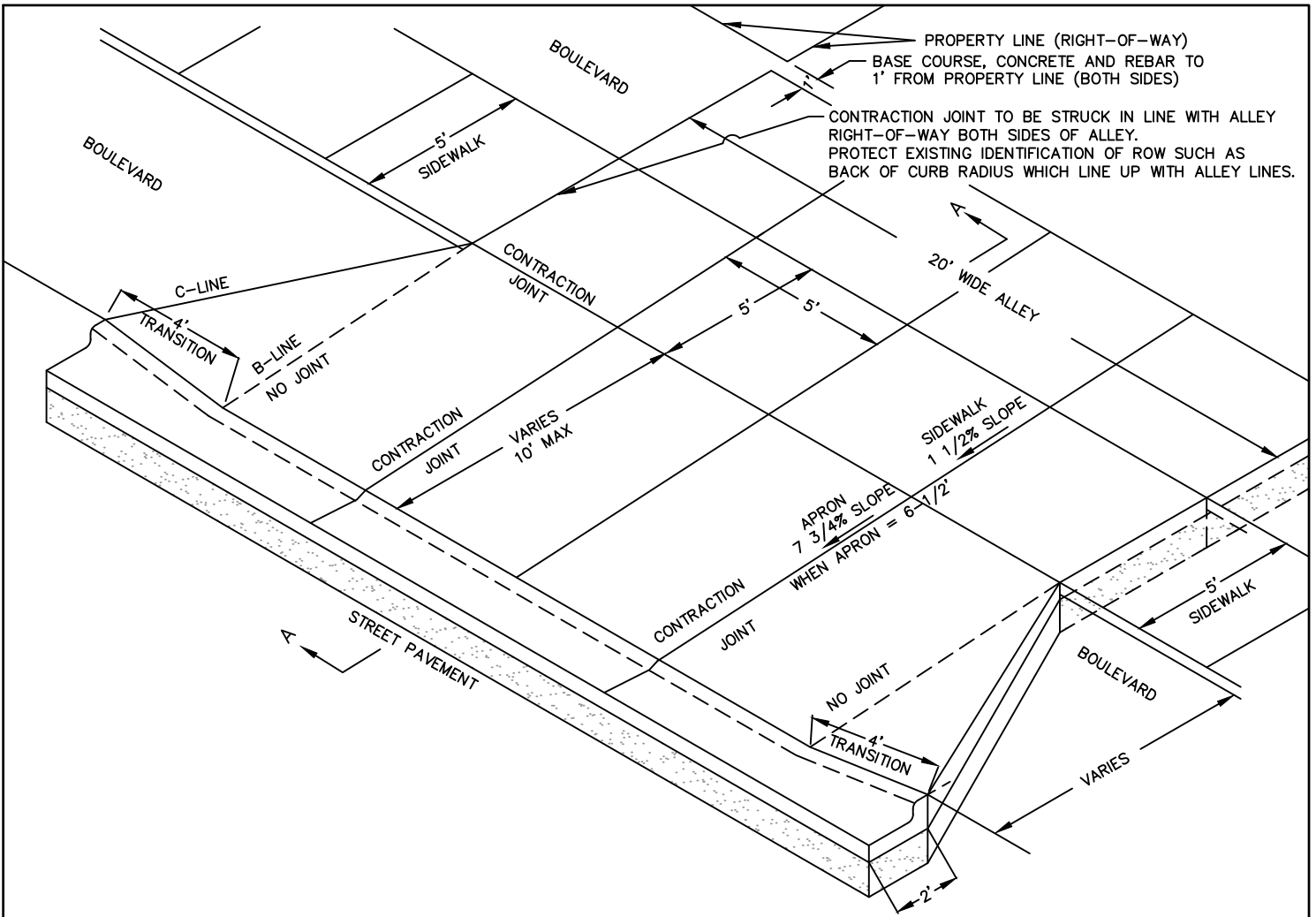

SECTION A-A

NOTES:

1. ALLEY APPROACH WILL BE PLACED MONOLITHICALLY. P/C CONCRETE SHALL BE 4000 P.S.I. AND MINIMUM 6.5 SACK.
2. ACI CERTIFICATION IS REQUIRED FOR PLACING AND FINISHING CONCRETE IN THE RIGHT-OF-WAY.
3. THE DESIGN SHALL CONSIDER A TRANSITION FROM THE ALLEY SURFACE TO ALLOW FOR DRAINAGE THROUGH THE APRON TO THE CURB WHILE MAINTAINING ADA COMPLIANCE.

NO SCALE

STANDARD DETAIL FOR CONCRETE ALLEY APRON WHERE SIDEWALK NOT AT BACK OF CURB - TYPE 1

OFFICE OF CITY ENGINEER  
 GREAT FALLS, MONTANA

REVISED OCTOBER 2023

5 - 08A

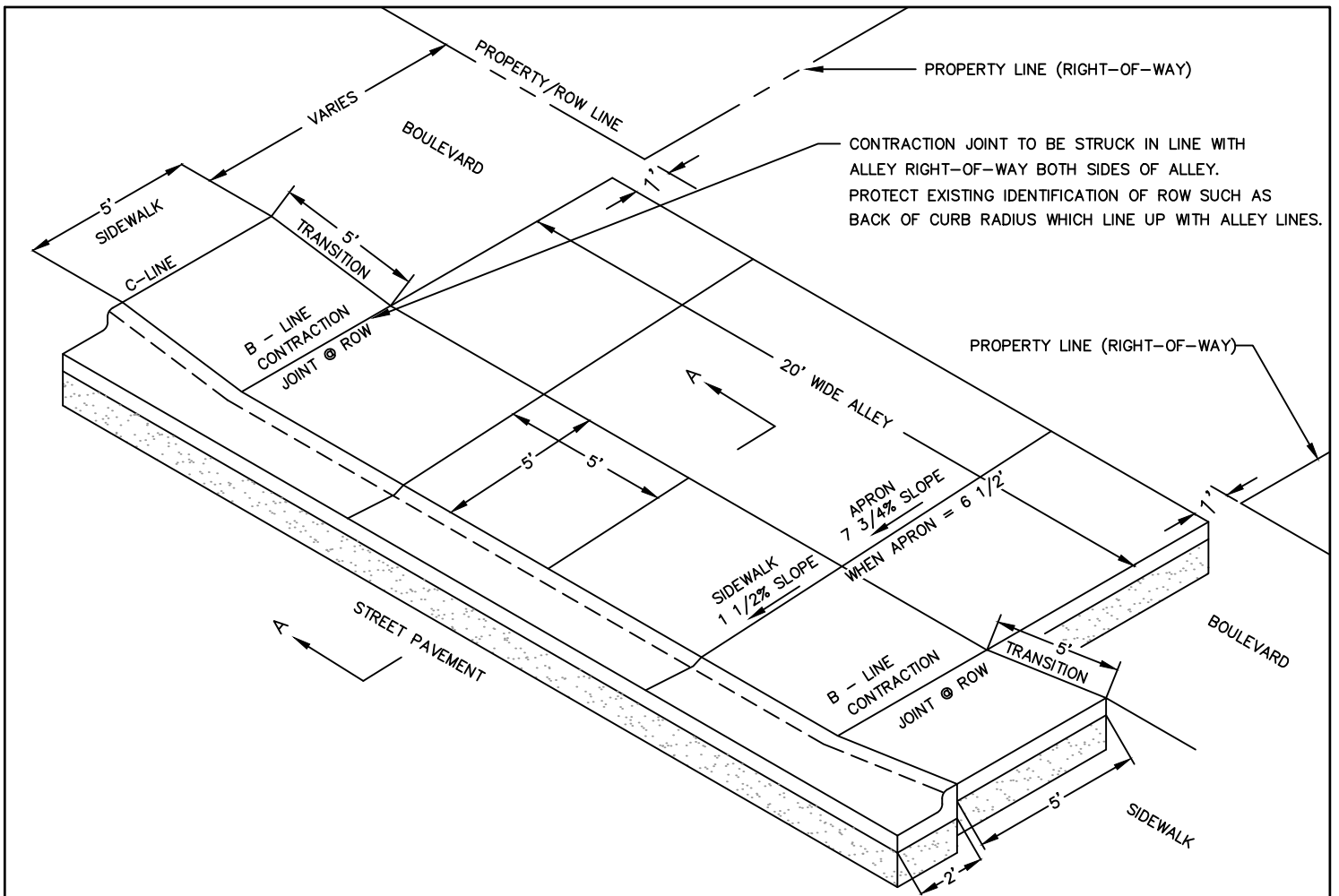

CONTRACTION JOINT TO BE STRUCK IN LINE WITH ALLEY RIGHT-OF-WAY BOTH SIDES OF ALLEY. PROTECT EXISTING IDENTIFICATION OF ROW SUCH AS BACK OF CURB RADIUS WHICH LINE UP WITH ALLEY LINES.

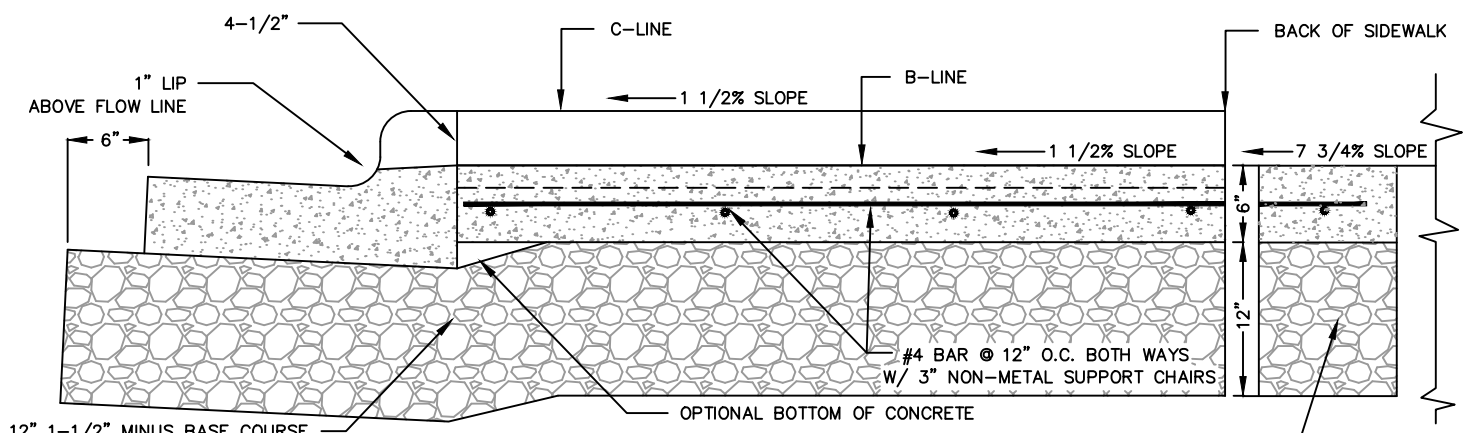

SECTION A-A

- NOTES:
1. ALLEY APPROACH WILL BE PLACED MONOLITHICALLY. P/C CONCRETE SHALL BE 4000 P.S.I. AND MINIMUM 6.5 SACK.
  2. ACI CERTIFICATION IS REQUIRED FOR PLACING AND FINISHING CONCRETE IN THE RIGHT-OF-WAY.
  3. THE DESIGN SHALL CONSIDER A TRANSITION FROM THE ALLEY SURFACE TO ALLOW FOR DRAINAGE THROUGH THE APRON TO THE CURB WHILE MAINTAINING ADA COMPLIANCE.

NO SCALE

STANDARD DETAIL FOR CONCRETE ALLEY APRON WITH SIDEWALK AT CURB – TYPE 2

OFFICE OF CITY ENGINEER  
GREAT FALLS, MONTANA

REVISED: OCTOBER 2023

5 – 08B

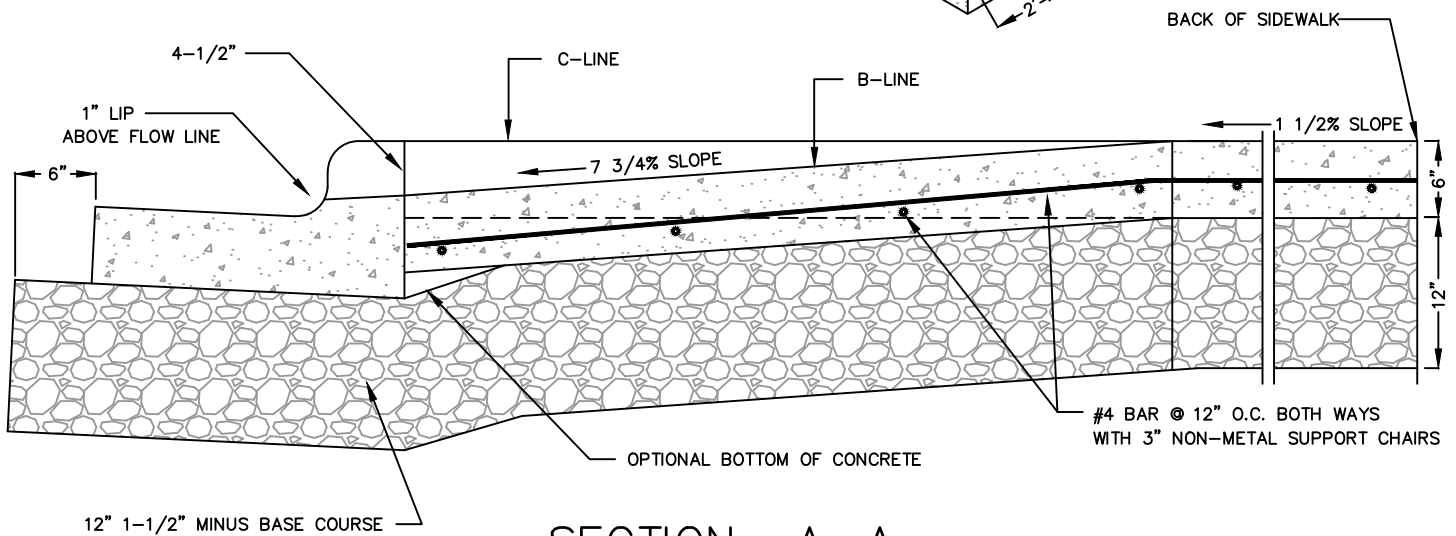
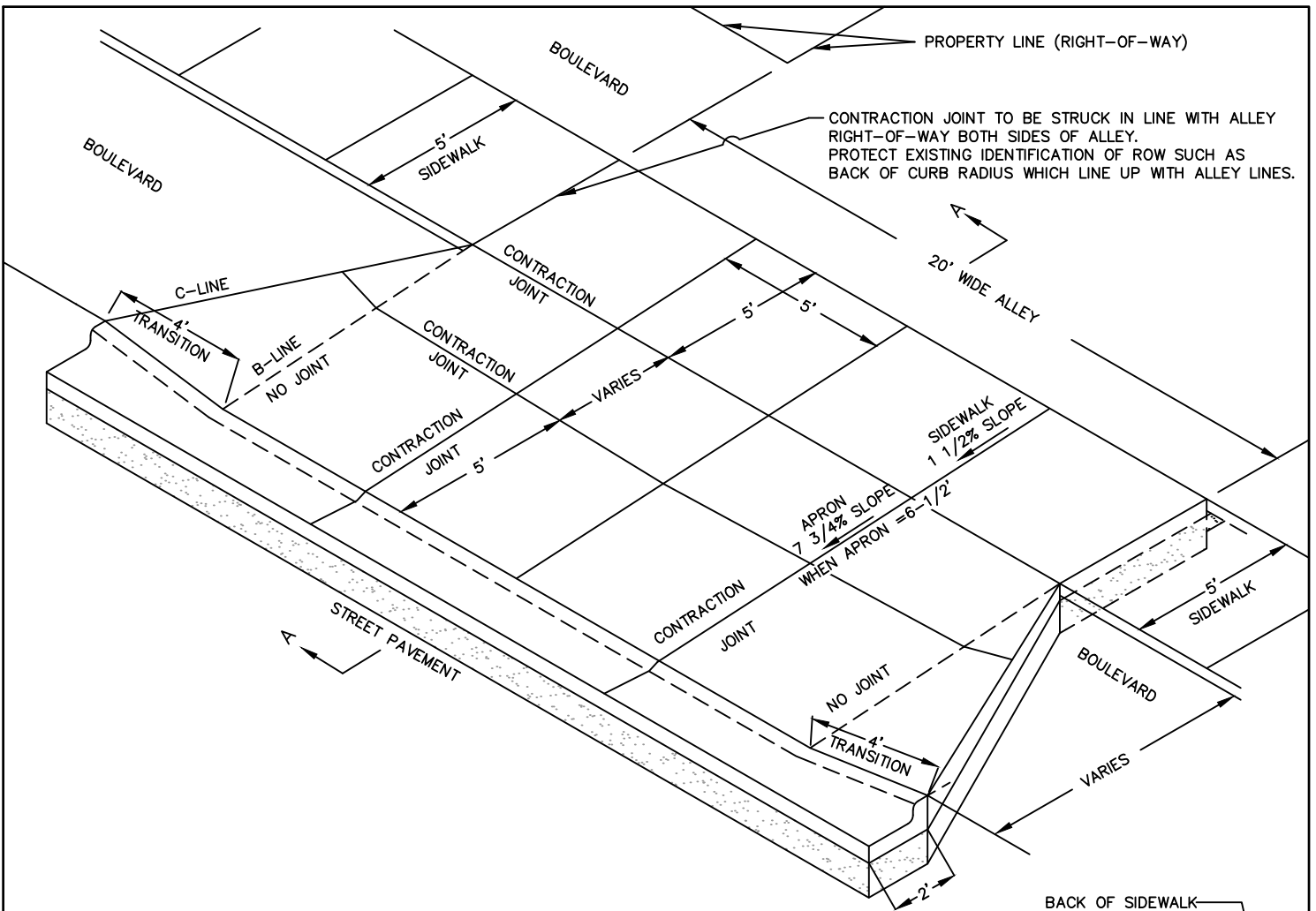

**NOTES:**

1. ALLEY APPROACH WILL BE PLACED MONOLITHICALLY. P/C CONCRETE SHALL BE 4000 P.S.I. AND MINIMUM 6.5 SACK.
2. ACI CERTIFICATION IS REQUIRED FOR PLACING AND FINISHING CONCRETE IN THE RIGHT-OF-WAY.
3. THE DESIGN SHALL CONSIDER A TRANSITION FROM THE ALLEY SURFACE TO ALLOW FOR DRAINAGE THROUGH THE APRON TO THE CURB WHILE MAINTAINING ADA COMPLIANCE.

NO SCALE

**STANDARD DETAIL FOR CONCRETE ALLEY APRON  
 WHERE SIDEWALK NOT AT BACK OF CURB - TYPE 3**

OFFICE OF CITY ENGINEER  
 GREAT FALLS, MONTANA

REVISED: OCTOBER 2023

5 - 08C

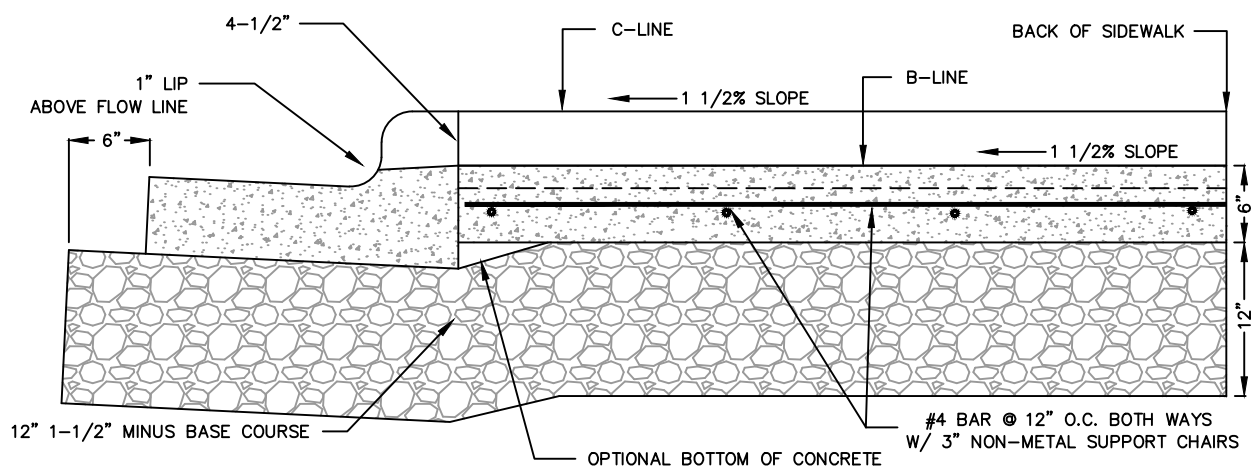
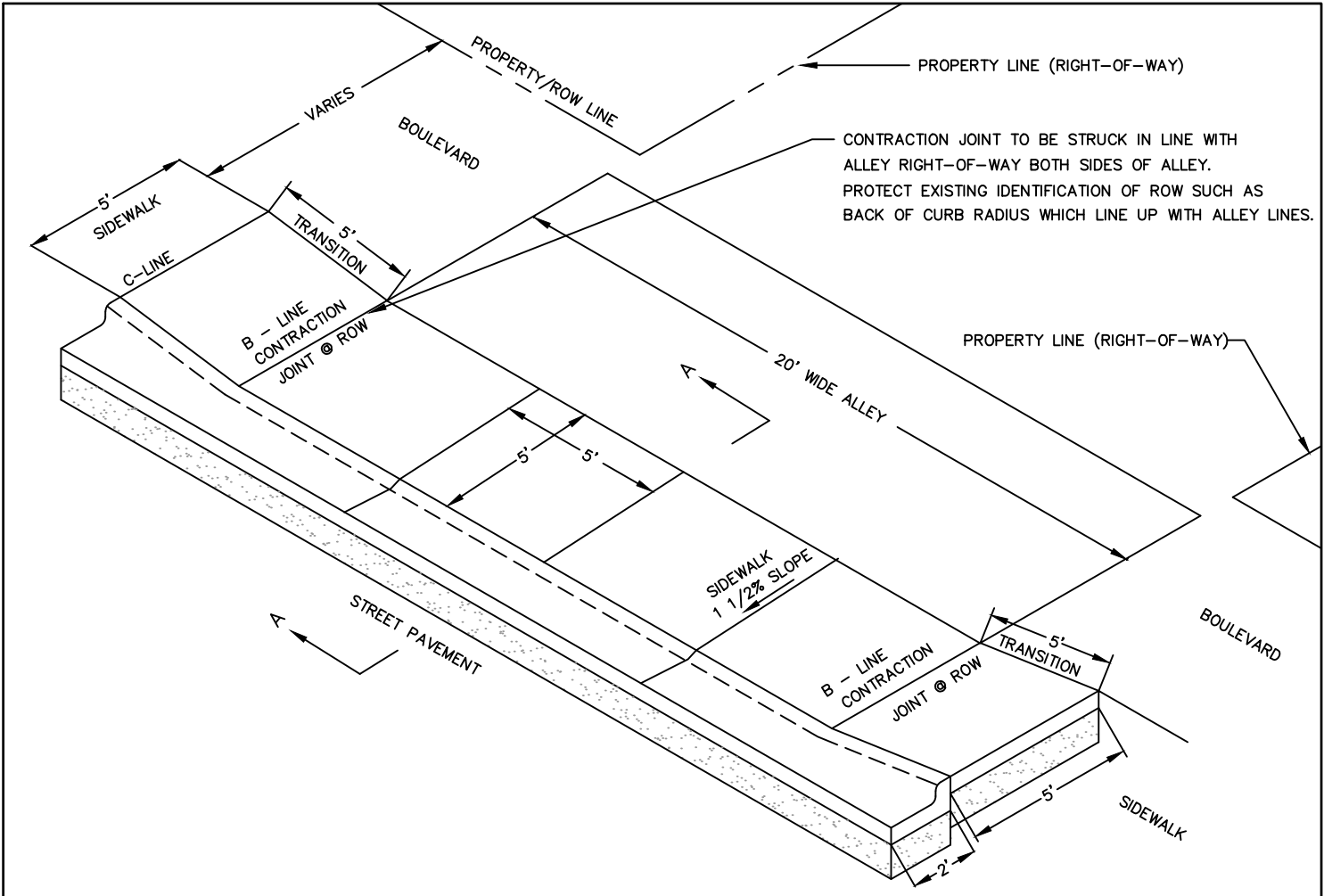

SECTION A-A

NOTES:

1. ALLEY APPROACH WILL BE PLACED MONOLITHICALLY. P/C CONCRETE SHALL BE 4000 P.S.I. AND MINIMUM 6.5 SACK.
2. ACI CERTIFICATION IS REQUIRED FOR PLACING AND FINISHING CONCRETE IN THE RIGHT-OF-WAY.
3. THE DESIGN SHALL CONSIDER A TRANSITION FROM THE ALLEY SURFACE TO ALLOW FOR DRAINAGE THROUGH THE APRON TO THE CURB WHILE MAINTAINING ADA COMPLIANCE.

NO SCALE

STANDARD DETAIL FOR CONCRETE ALLEY APRON WITH SIDEWALK AT CURB – TYPE 4

OFFICE OF CITY ENGINEER  
GREAT FALLS, MONTANA

REVISED: OCTOBER 2023

5 – 08D



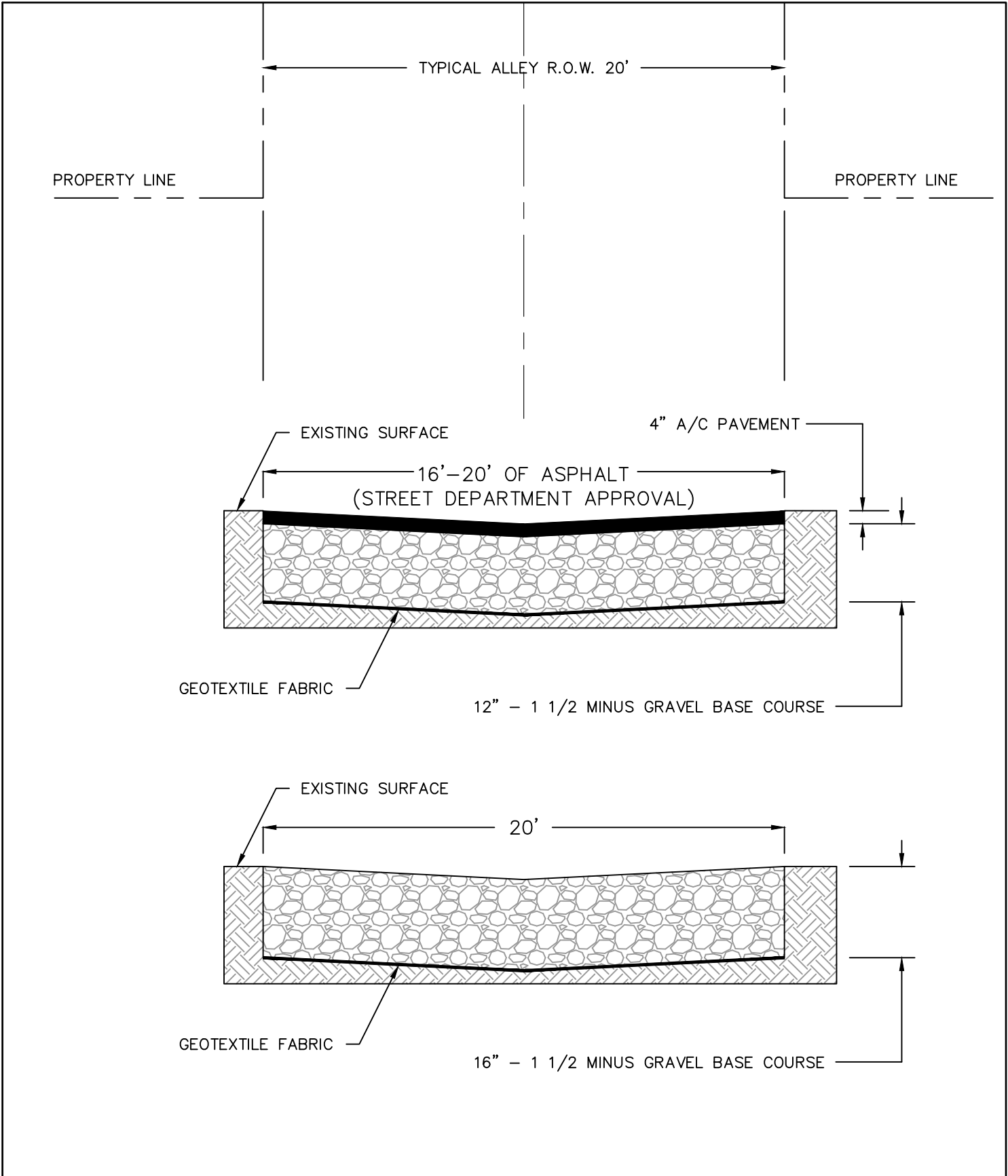

**STANDARD DETAIL FOR ASPHALT OR GRAVEL  
PAVING OF PUBLIC ALLEY**

OFFICE OF CITY ENGINEER  
GREAT FALLS, MONTANA

APRIL 1994  
REVISED: OCTOBER 2023

5 - 09

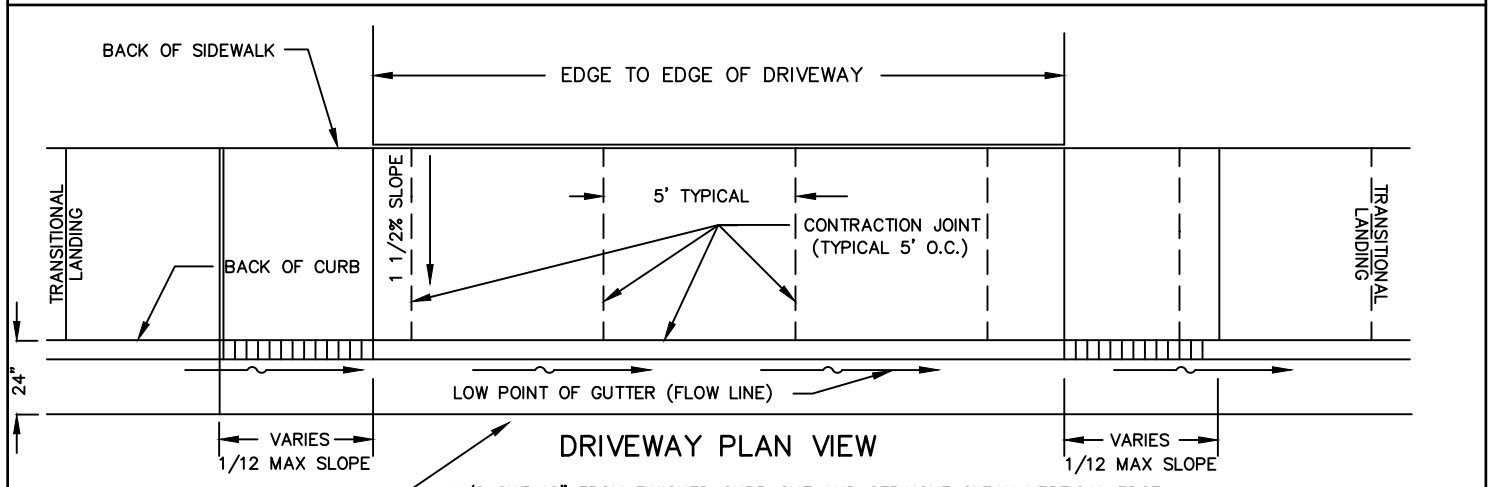
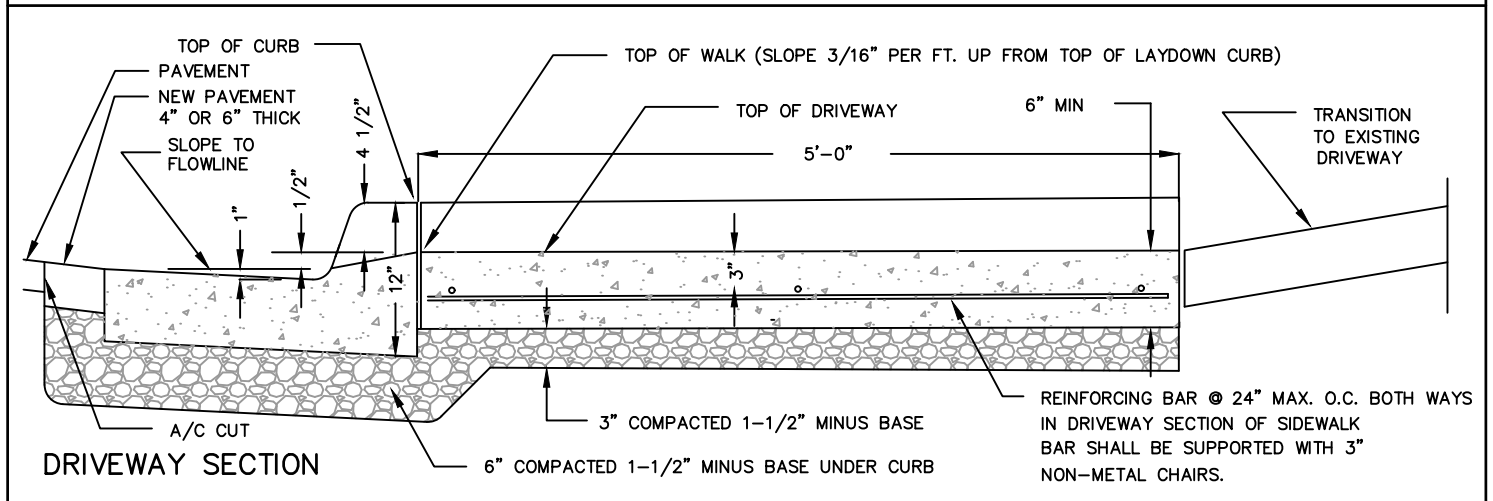
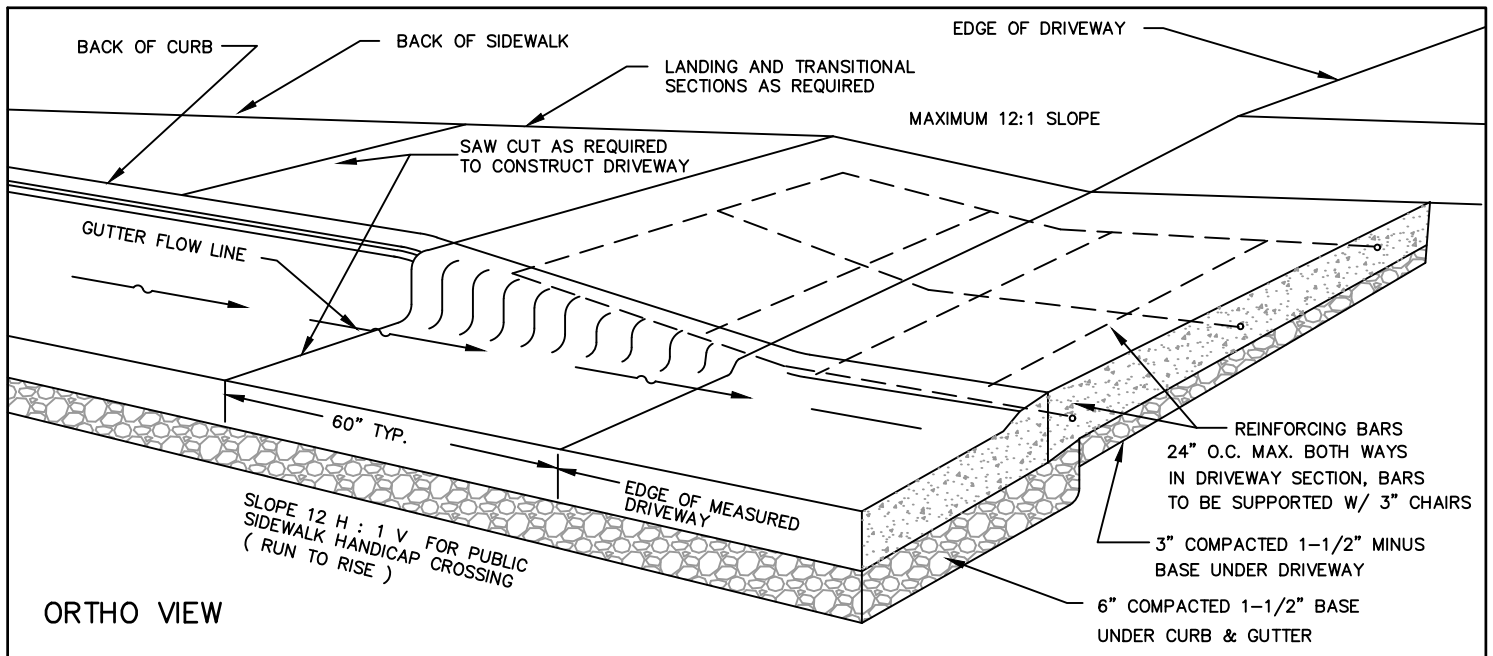

**NOTES:**

1. LANDINGS ON BOTH SIDES OF CURB TRANSITIONS SHALL BE ADA COMPLIANT. SACRIFICIAL PANELS MAY BE REQUIRED TO MATCH EXISTING SIDEWALK.
2. ACI CERTIFICATION IS REQUIRED FOR PLACING AND FINISHING CONCRETE IN THE RIGHT-OF-WAY.

**CURB AND SIDEWALK SECTION FOR DRIVEWAYS  
WITH SIDEWALK AT CURB**

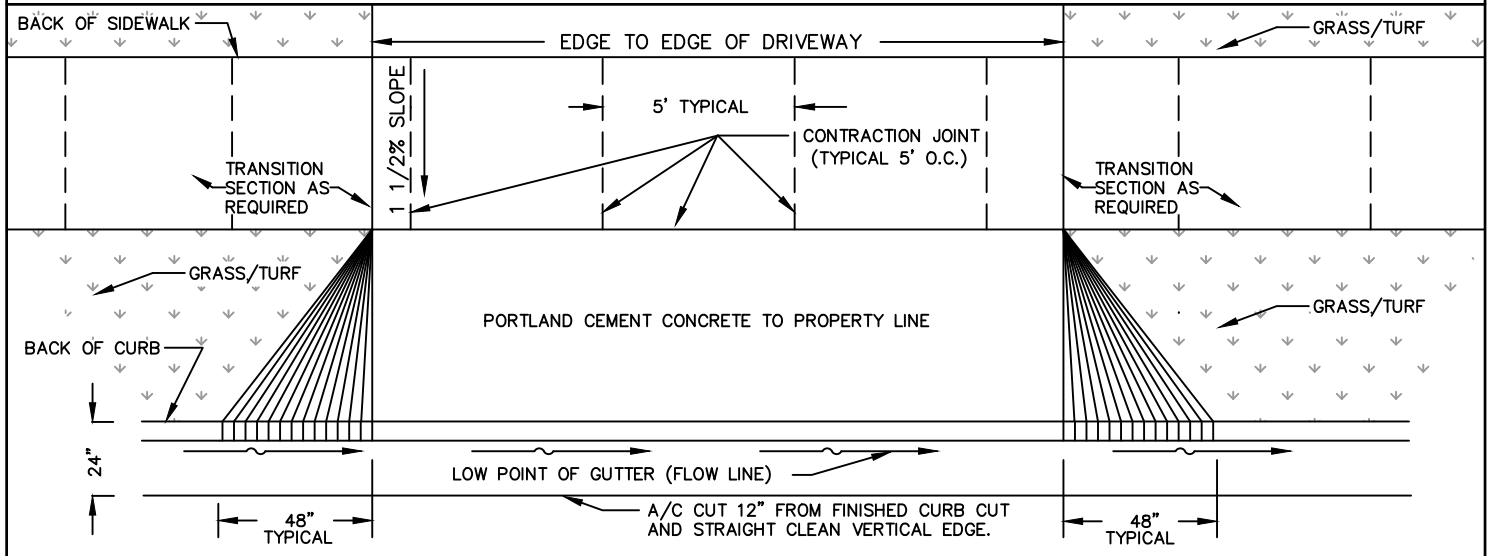
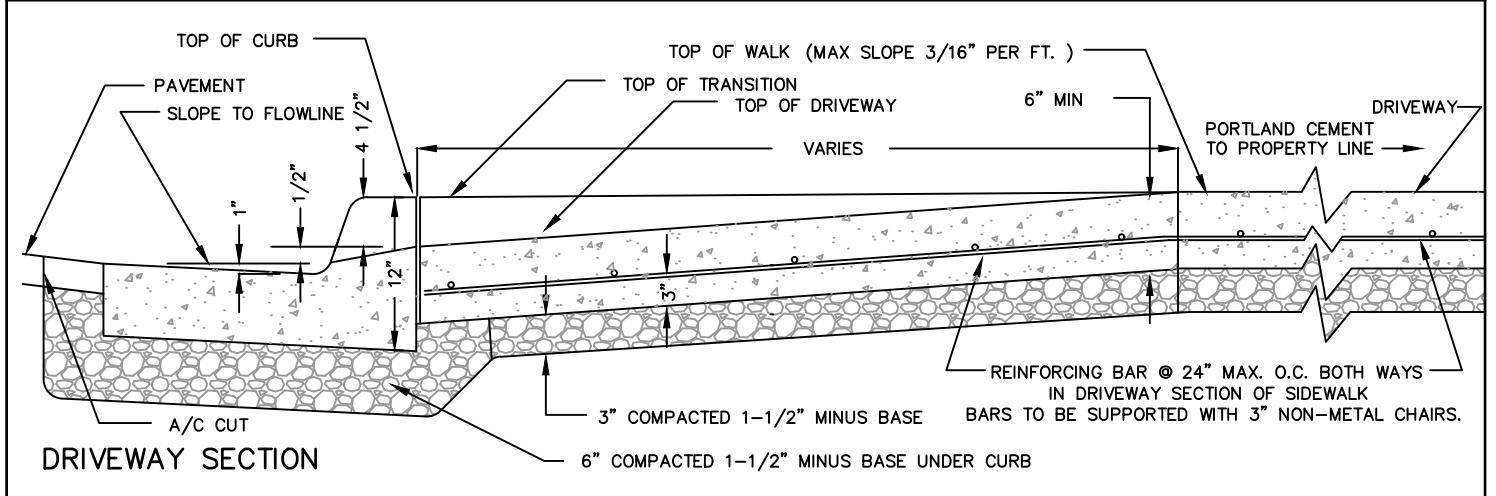
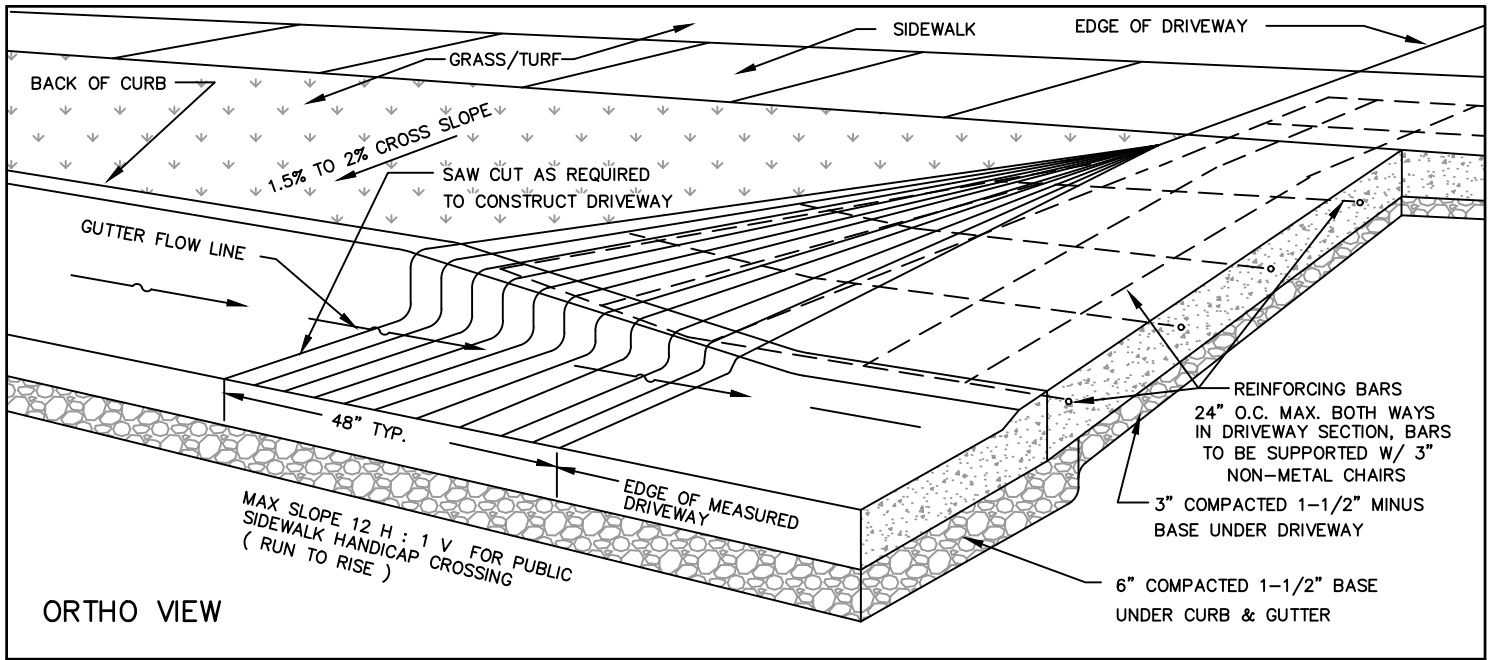

NOTE: ACI CERTIFICATION IS REQUIRED FOR PLACING AND FINISHING CONCRETE IN THE RIGHT-OF-WAY.

## CURB AND SIDEWALK SECTION FOR DRIVEWAYS WITH GRASS BOULEVARD BETWEEN CURB AND WALK

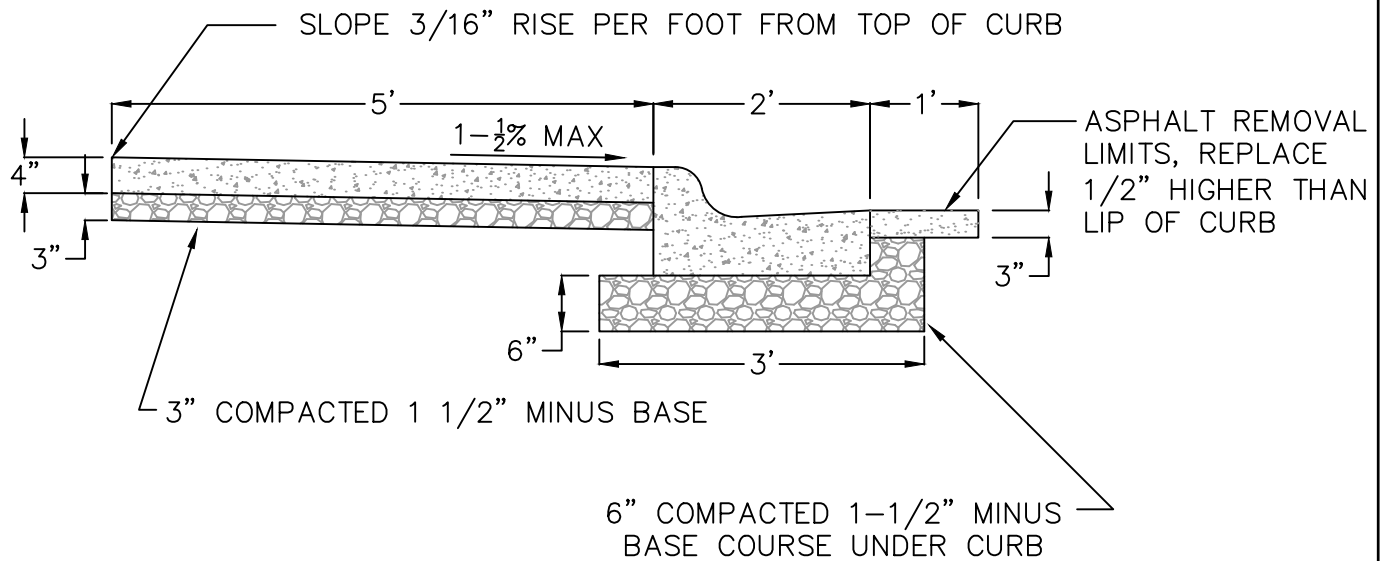

NOTES:

1. CURB & GUTTER SHALL HAVE A TOOLED CONTRACTION JOINT EVERY 10' AND BE SCORED A MIN. DEPTH OF  $3/4$ "
2. CURB & GUTTER AND SIDEWALK SHALL HAVE  $1/2$ " EXPANSION JOINT AT PC's, D.T's , CURB TURNS AND EVERY 100' ON STRAIGHT STRETCHES.
3. SIDEWALK SHALL HAVE A TOOLED CONTRACTION JOINT EVERY 5' AND BE SCORED A MIN. DEPTH OF  $3/4$ ".
4. ALL CONCRETE POURED INSIDE CITY R.O.W. SHALL BE MINIMUM 6.5 SACK AND 4000 PSI MIX DESIGN AND THE ENTRAINED AIR CONTENT SHALL BE  $\geq 5\%$  AND  $\leq 8\%$ .
5. PLACE AND COMPACT TO 95% STANDARD PROCTOR GRAVEL BASE COURSE AS REQUIRED IN SPECIFICATIONS
6. REMOVAL OF EXISTING SIDEWALK SHALL BE VIA A CLEAN SAWCUT.
7. ACI CERTIFICATION IS REQUIRED FOR PLACING AND FINISHING CONCRETE IN THE RIGHT-OF-WAY.

**CURB AND SIDEWALK SECTION**

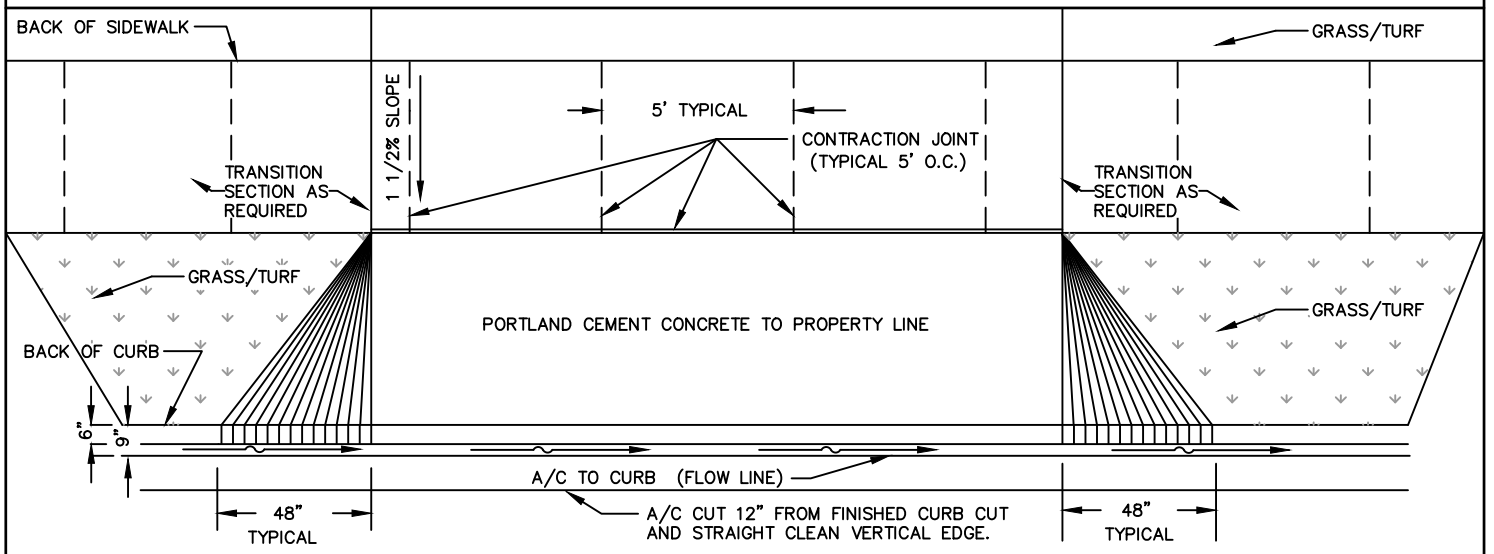
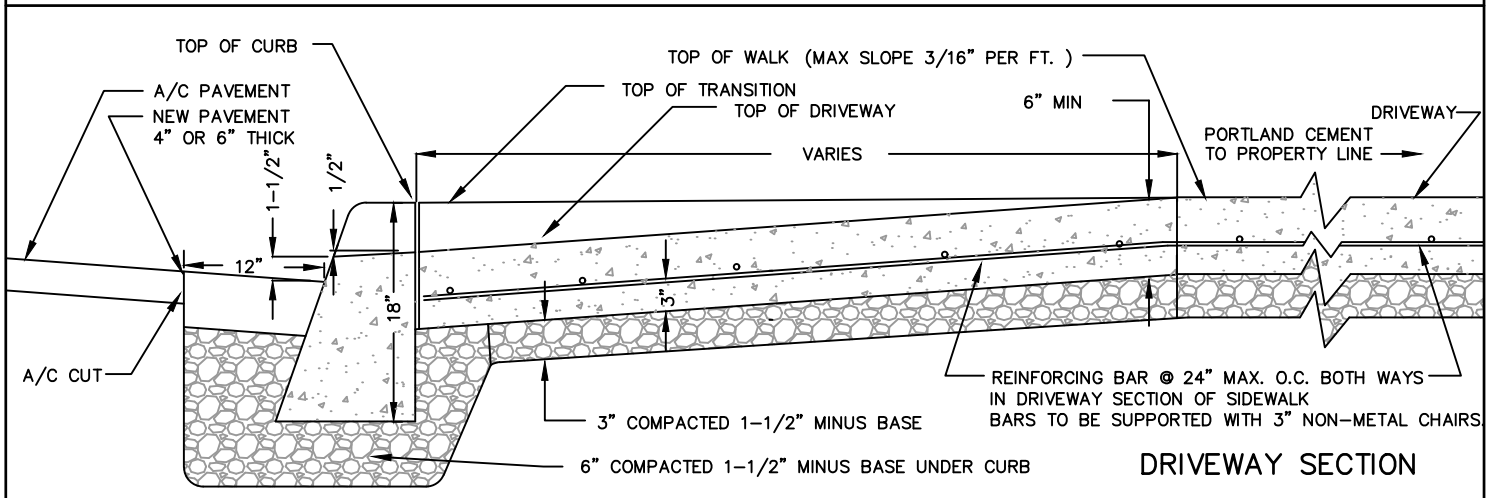
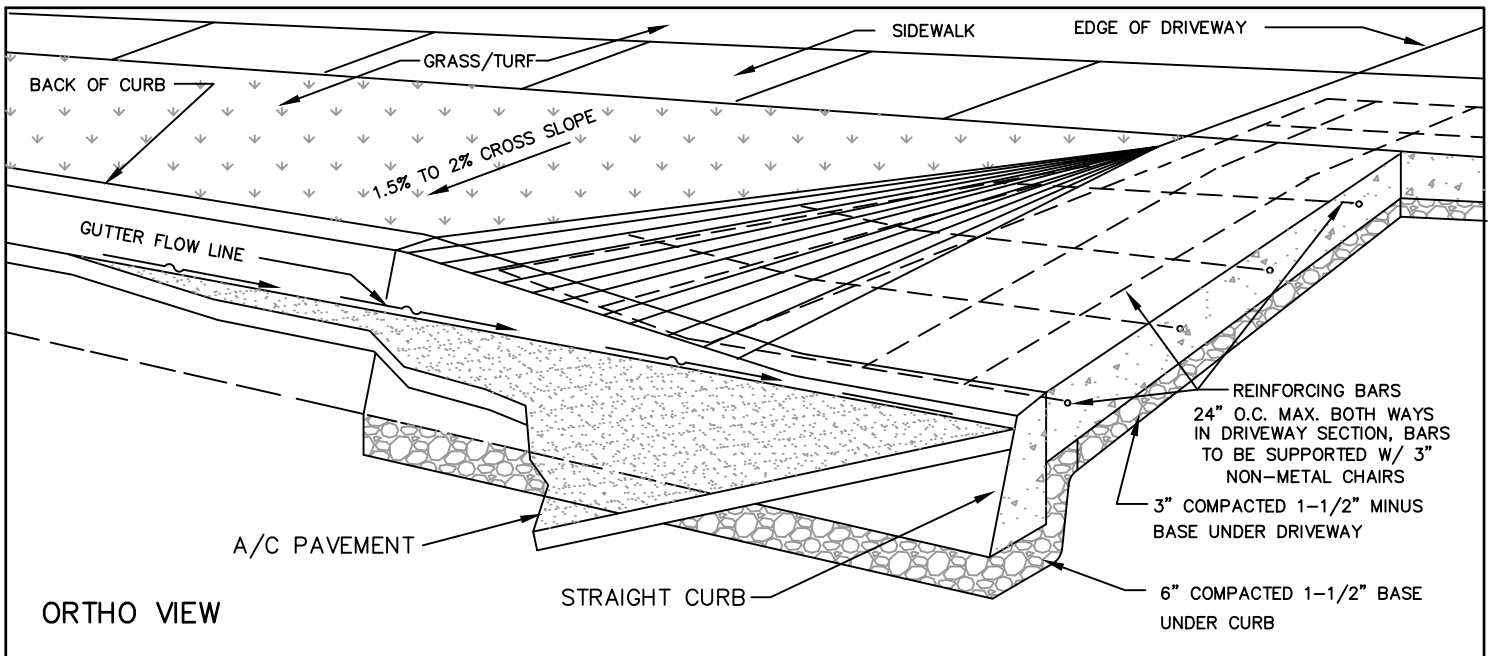

NOTE: ACI CERTIFICATION IS REQUIRED FOR PLACING AND FINISHING CONCRETE IN THE RIGHT-OF-WAY.

## STRAIGHT CURB AND SIDEWALK SECTION FOR DRIVEWAYS WITH GRASS BOULEVARD BETWEEN CURB AND SIDEWALK

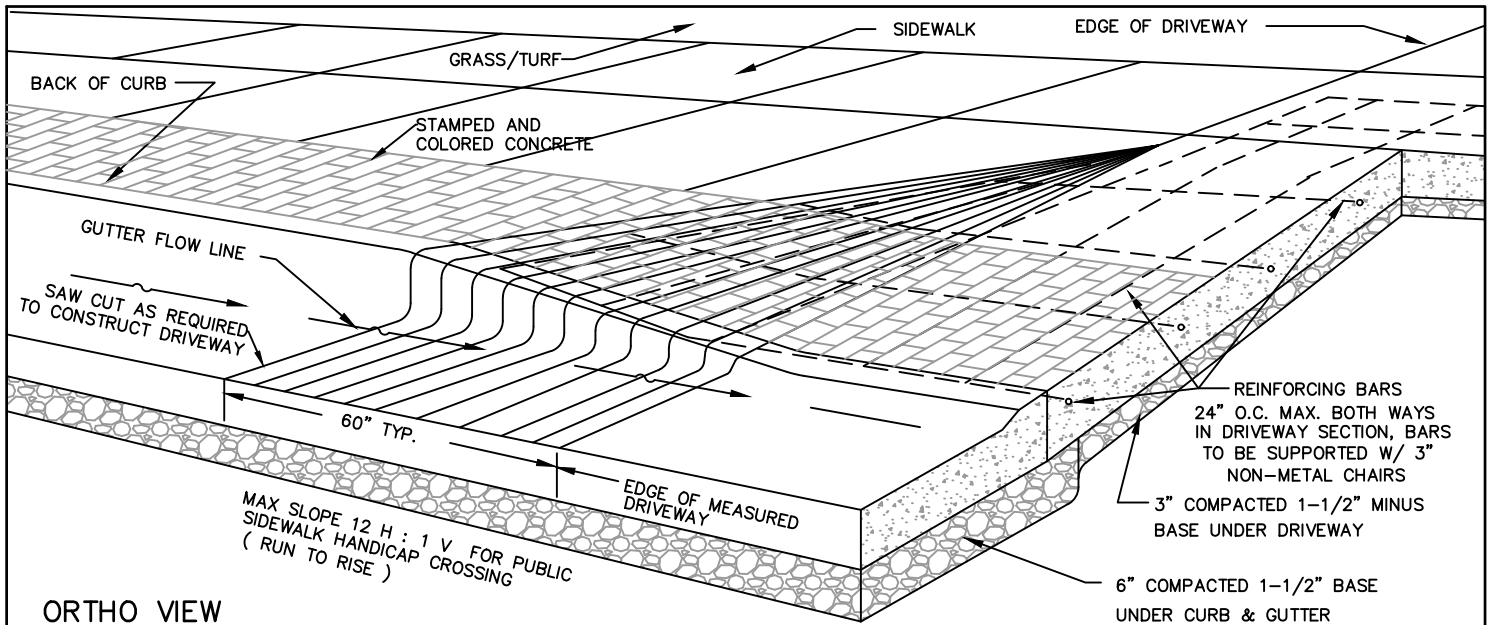

**ORTHO VIEW**

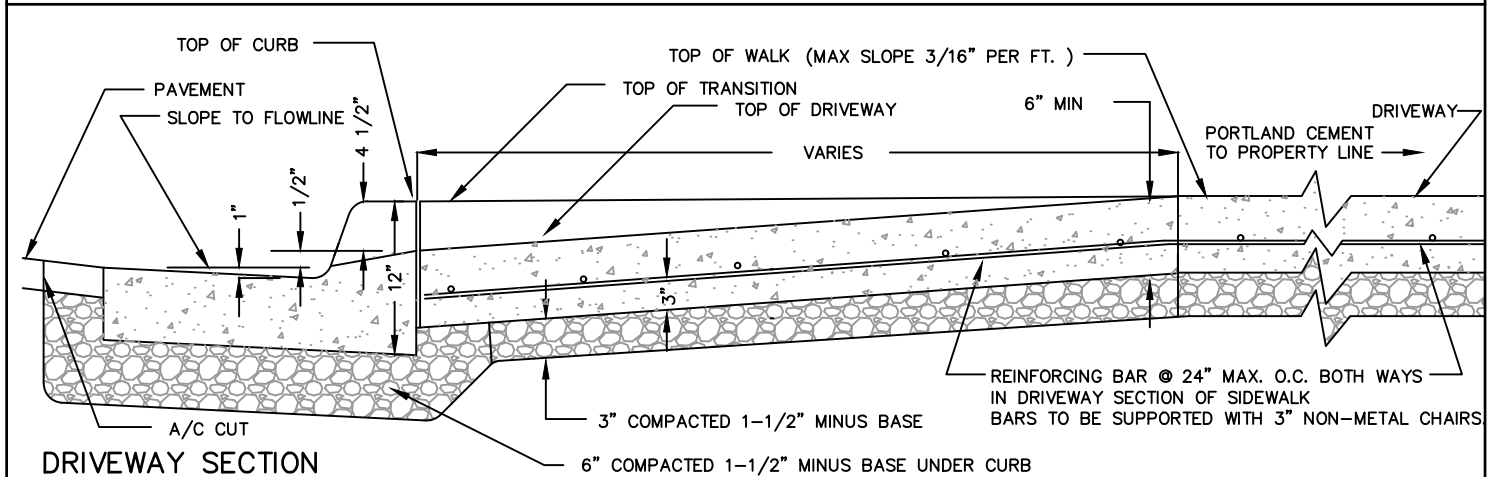

**DRIVEWAY SECTION**

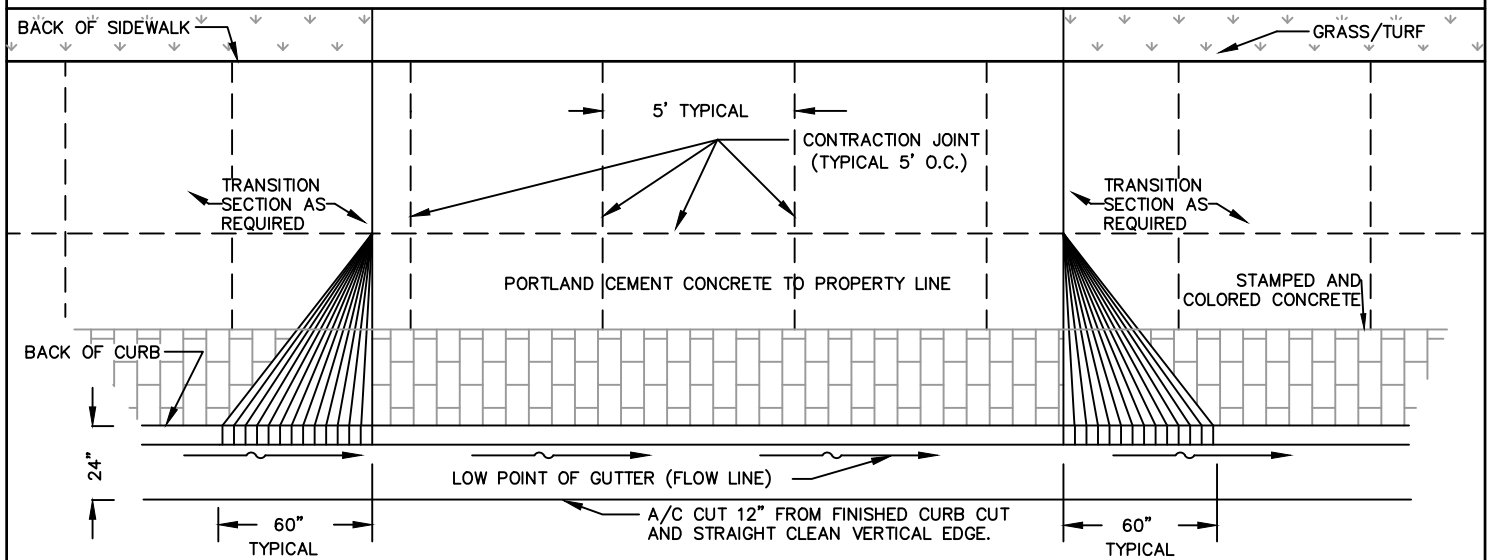

**DRIVEWAY PLAN VIEW**

NOTE: ACI CERTIFICATION IS REQUIRED FOR PLACING AND FINISHING CONCRETE IN THE RIGHT-OF-WAY.

## CURB AND SIDEWALK SECTION FOR DRIVEWAYS DOWNTOWN WITH STAMPED DECORATIVE BRICK PATTERN

OFFICE OF CITY ENGINEER  
GREAT FALLS, MONTANA

REVISED: SEPTEMBER 2023

5 - 10E

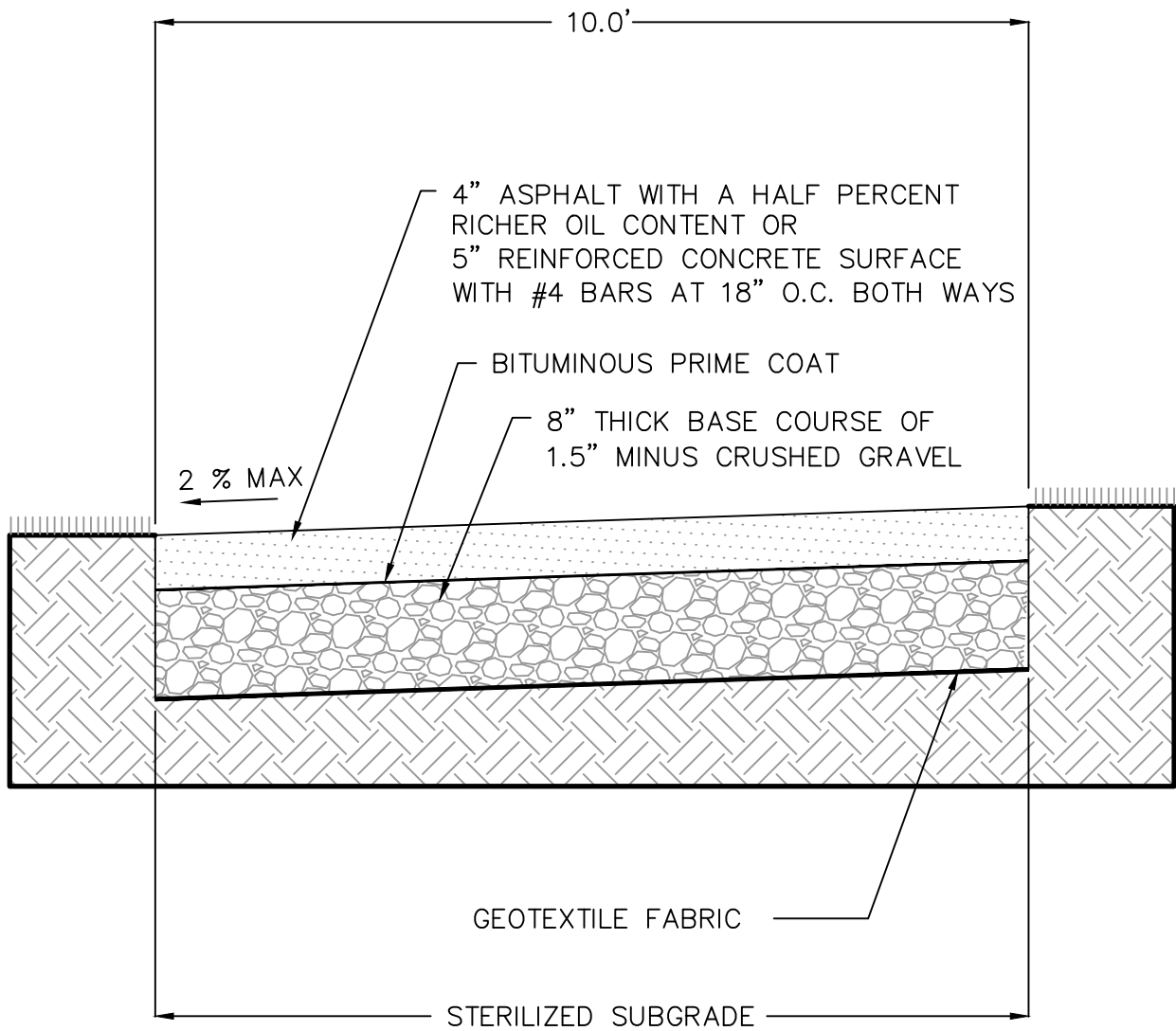

NOTES:

1. 2% MAX GRADE IS EQUAL TO 1/4" PER FOOT.
2. SAW CUT JOINTS AT AN INTERVAL EQUAL TO THE WIDTH AT MID SPAN OF TRANSVERSE BARS WITH HOT POURED THERMOPLASTIC RUBBER OR RUBBER ASPHALT SEALANT.
3. INSTALL EXPANSION JOINTS AT 150' INTERVALS WITH A 24" #5 SMOOTH DOWEL AT 18" ON CENTER AND PAINTED ON ONE END.

TYPICAL PARK PATH CROSS-SECTION

**PLAN**

**NOTES:**

1. THE DESIGN SHALL INCLUDE FINISH GRADE ELEVATIONS AT THE \* SHOWN.
2. ACI CERTIFICATION IS REQUIRED FOR PLACING AND FINISHING CONCRETE IN THE RIGHT-OF-WAY.

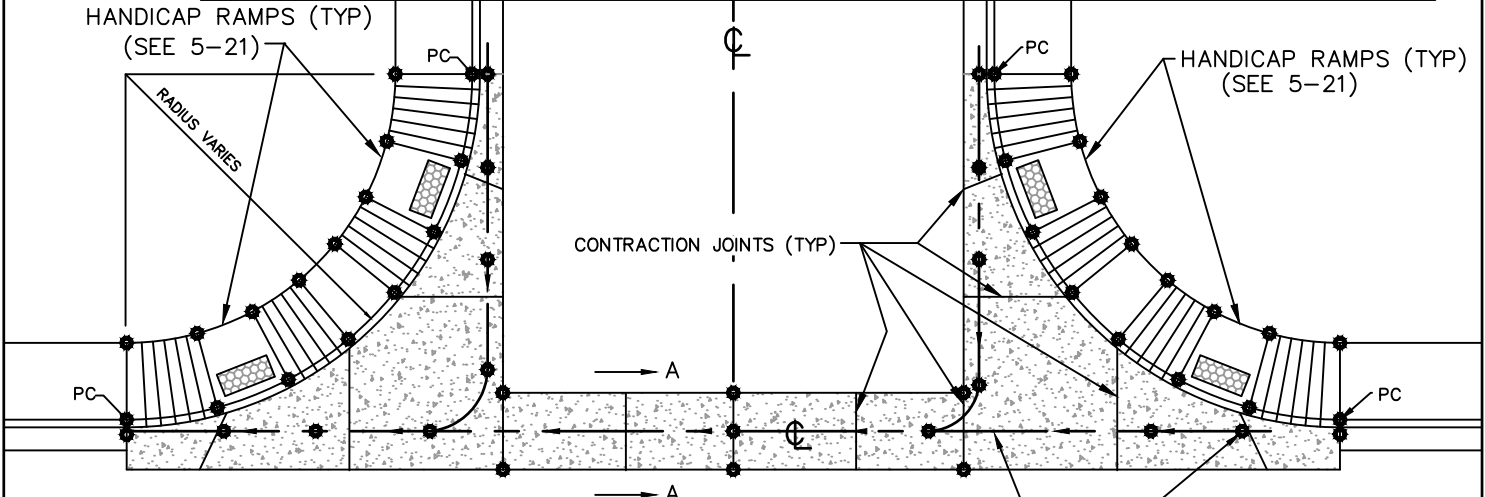

LINE UP CENTER OF VALLEY GUTTER WITH FLOW LINE OF CURB & GUTTER

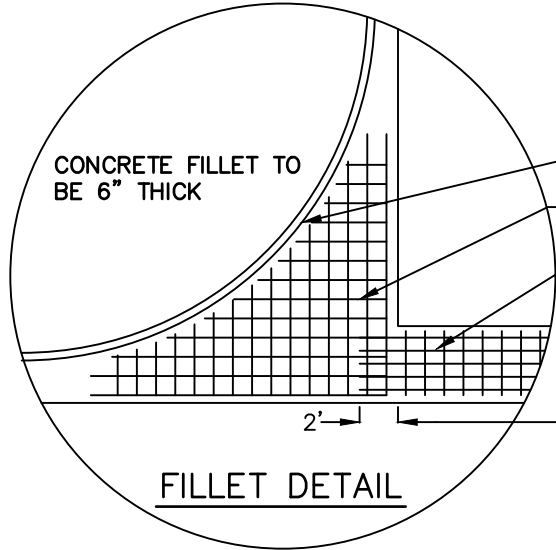

**FILLET DETAIL**

**SECTION A - A**

**NOTES:**

1. PAVEMENT REPLACEMENT SHALL OVERLAP 1/2" OVER LIP OF VALLEY GUTTER
2. BARS TO BE SUPPORTED BY 3" NON-METAL CHAIRS

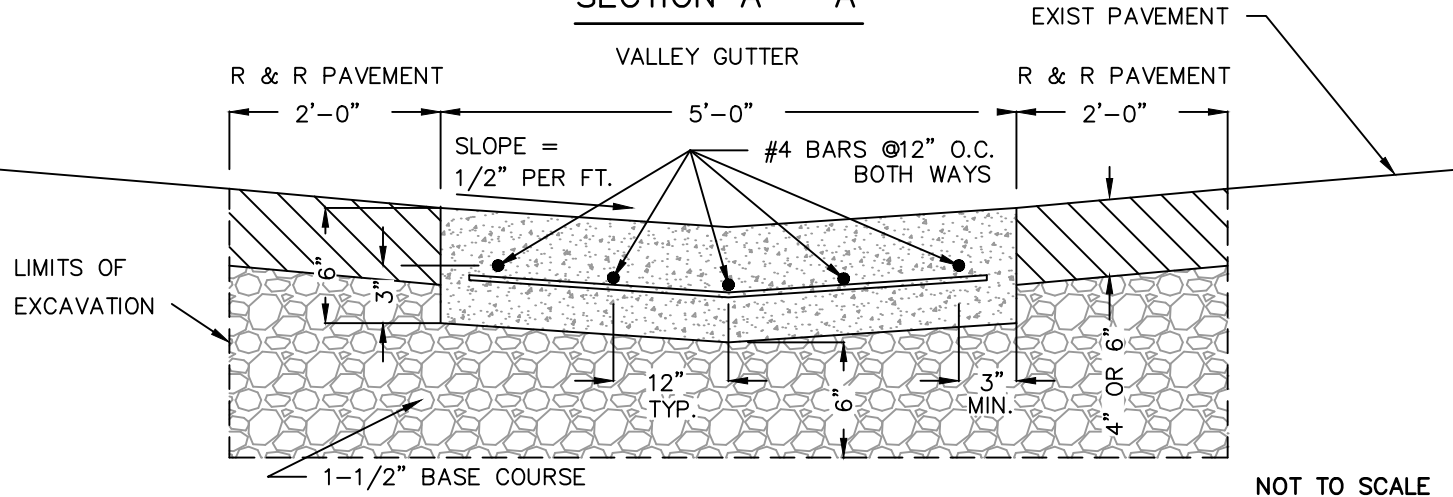

NOT TO SCALE

**VALLEY GUTTER WITH CORNER CURB FILLETS & DOUBLE RAMPS**



**PLAN**

**NOTES:**

1. THE DESIGN SHALL INCLUDE FINISH GRADE ELEVATIONS AT THE \* SHOWN.
2. ACI CERTIFICATION IS REQUIRED FOR PLACING AND FINISHING CONCRETE IN THE RIGHT-OF-WAY.

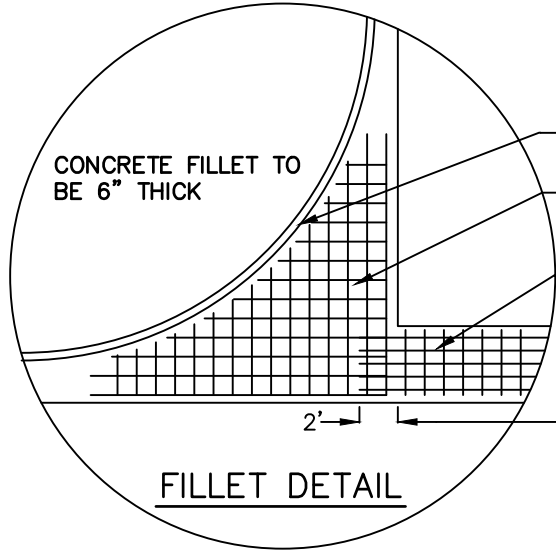
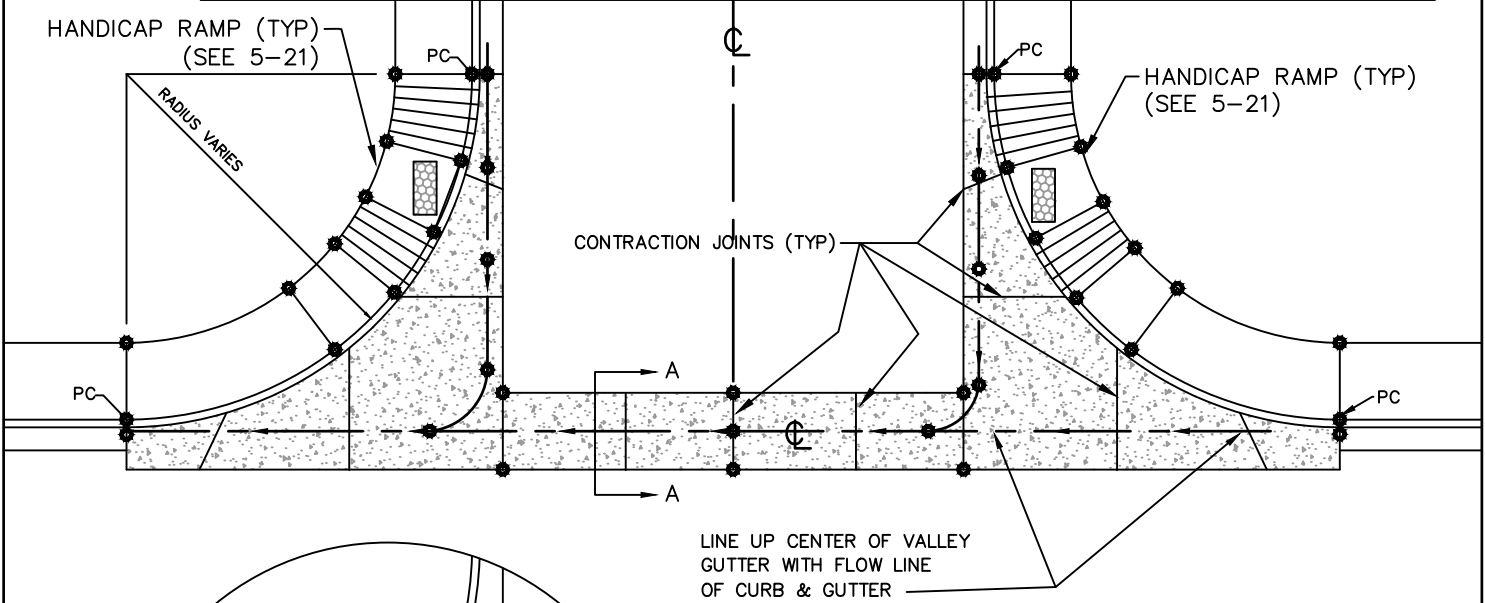

- DOWEL INTO CURB, 18" O.C.
- #4 BAR, 12" O.C. BOTH WAYS
- #4 BARS 12" O.C. BOTH WAYS
- TIE #4 BAR IN 2' OVERLAP

**NOTES:**

1. PAVEMENT REPLACEMENT SHOULD OVERLAP 1/2" OVER LIP OF VALLEY GUTTER
2. BARS TO BE SUPPORTED BY 3" NON-METAL CHAIRS

**SECTION A - A**

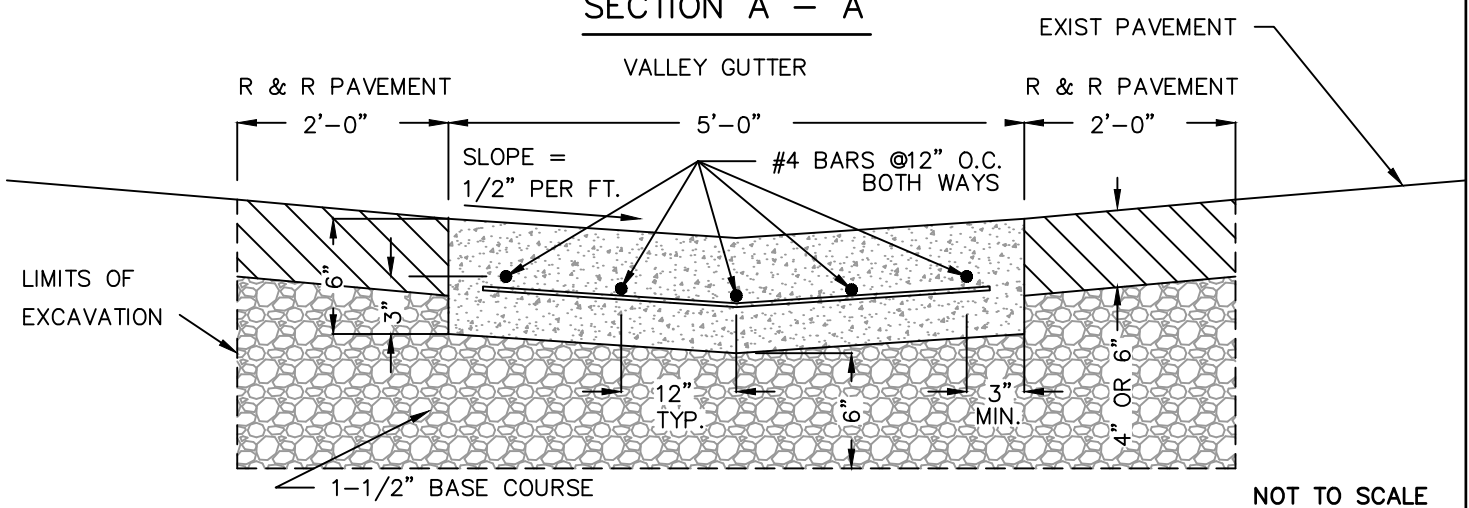

**VALLEY GUTTER WITH CORNER CURB FILLETS & SINGLE RAMPS**

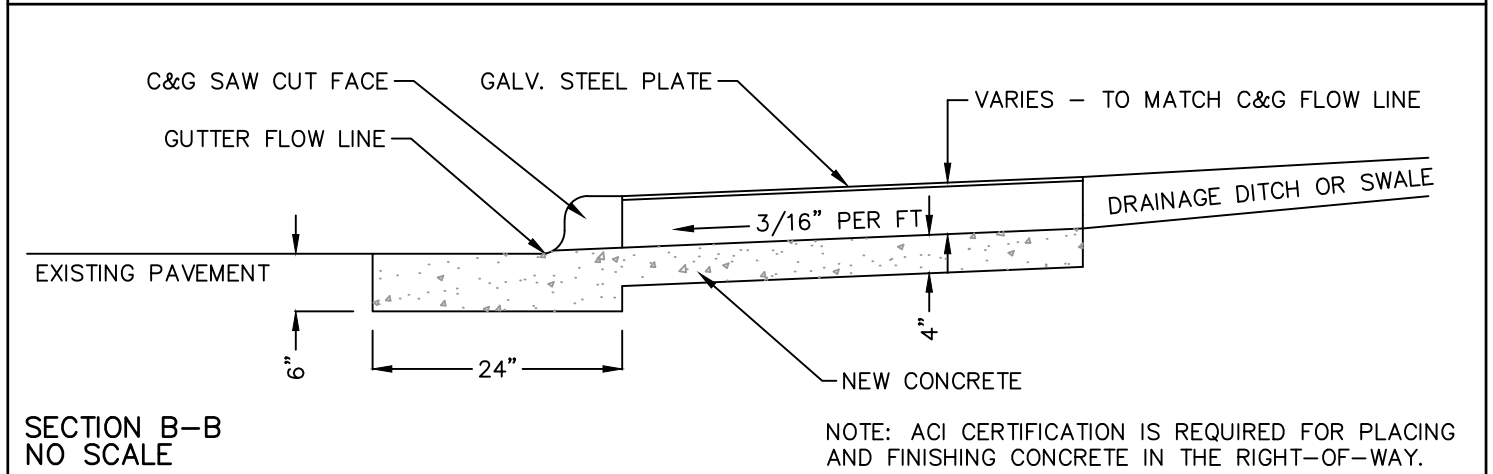
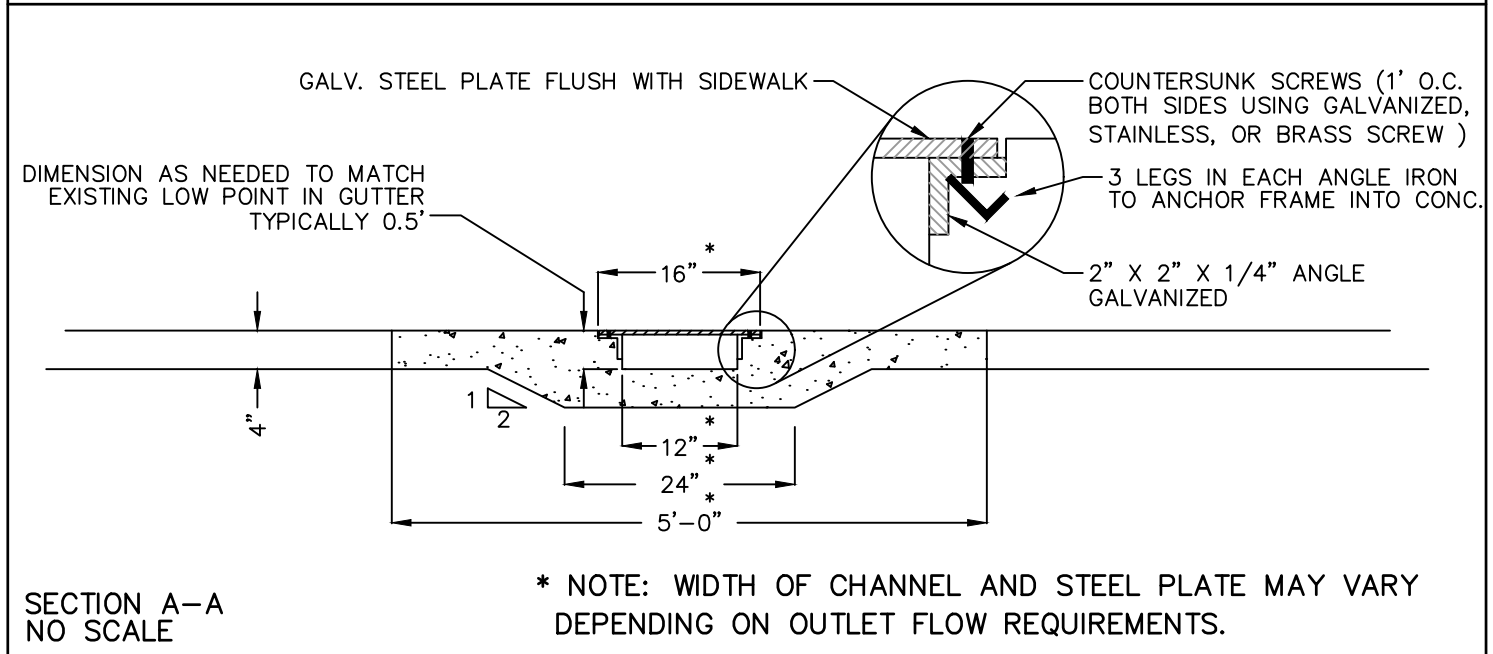
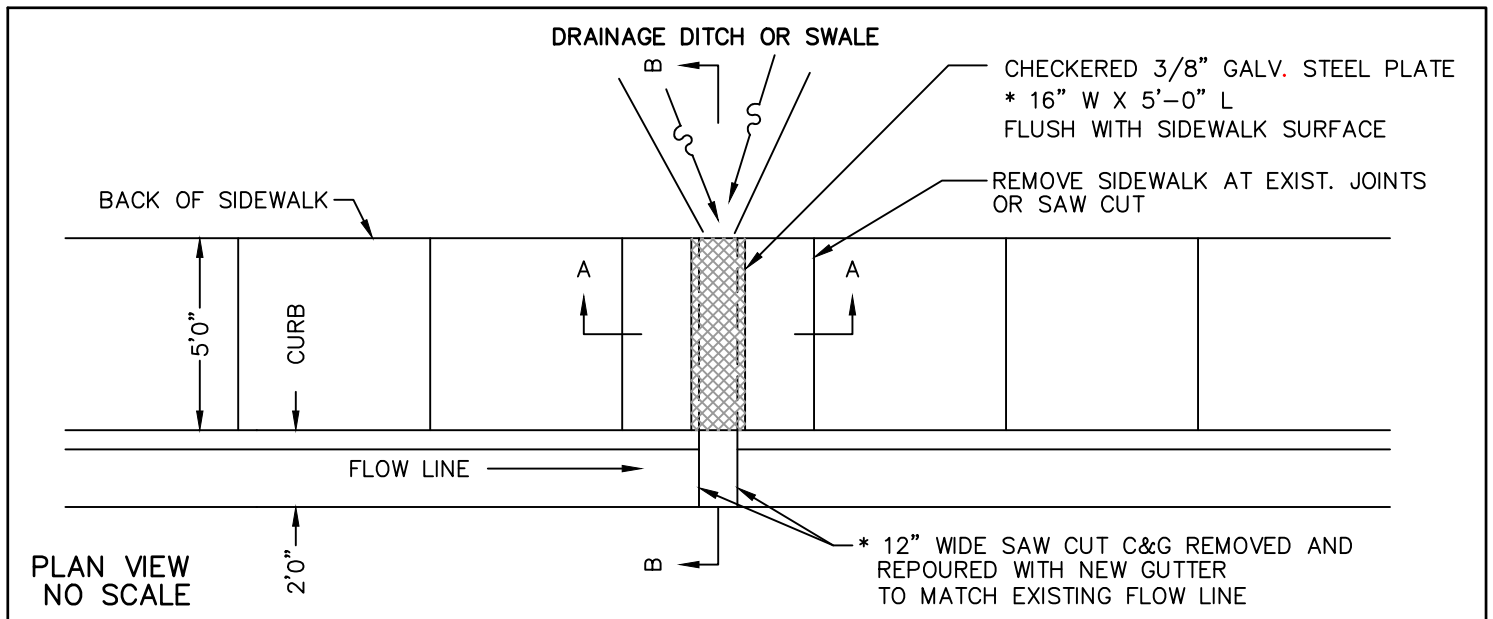

## TYPICAL SIDEWALK DRAINAGE CROSSING GUTTER DETAIL

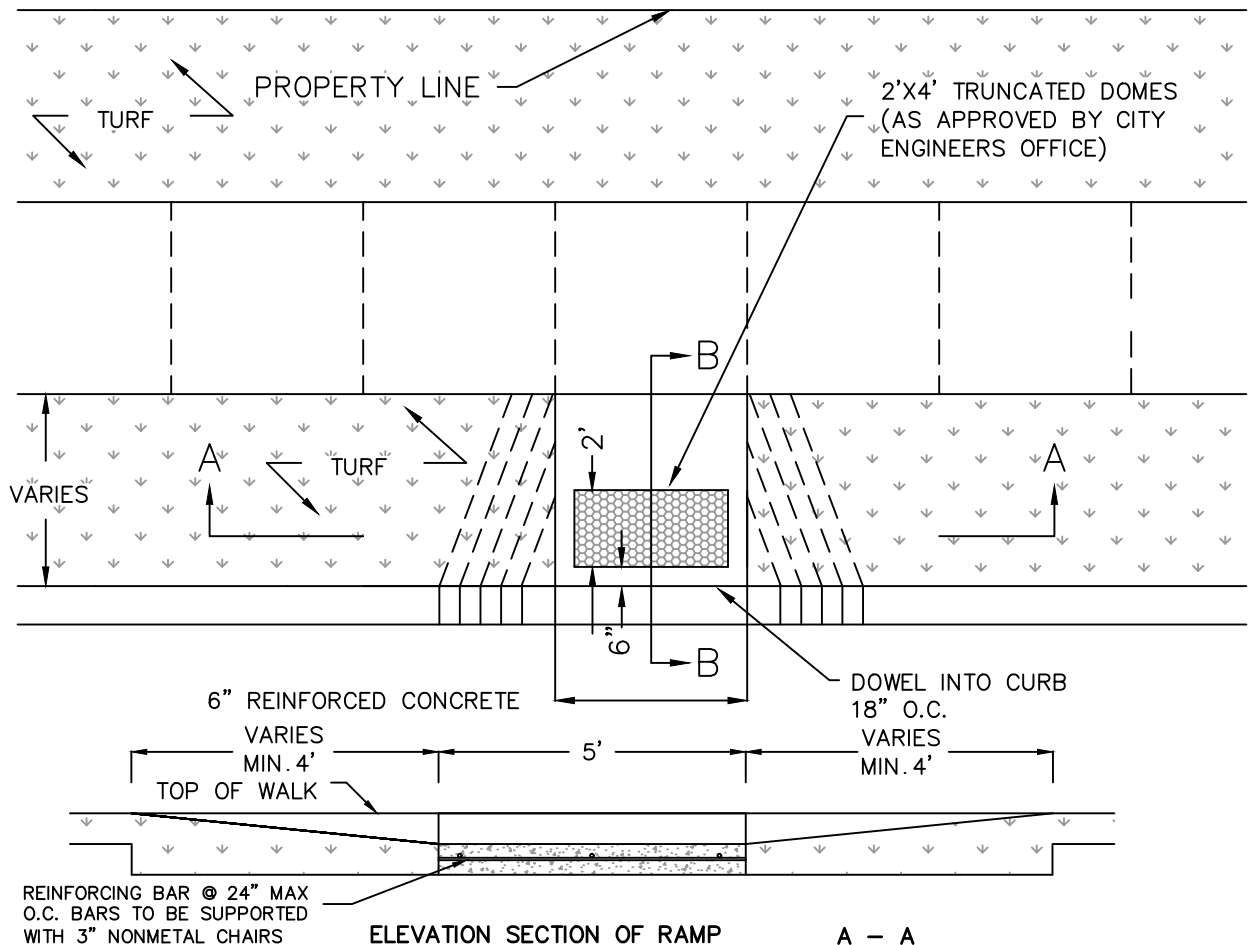

REINFORCING BAR @ 24" MAX O.C. BARS TO BE SUPPORTED WITH 3" NONMETAL CHAIRS

ELEVATION SECTION OF RAMP A - A

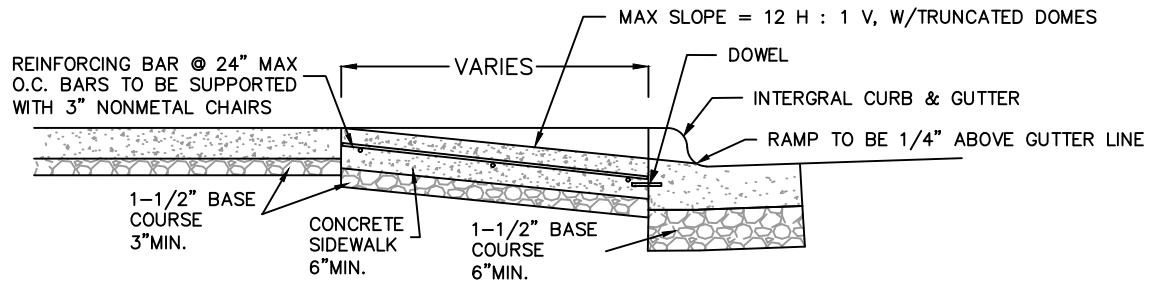

REINFORCING BAR @ 24" MAX O.C. BARS TO BE SUPPORTED WITH 3" NONMETAL CHAIRS

CROSS SECTION OF RAMP B - B

NOT TO SCALE

NOTES :

1. SURFACE TEXTURE OF RAMP SHALL BE THAT OBTAINED BY A COARSE BROOMING TRAVERSE TO THE SLOPE OF THE RAMP.
2. CARE SHALL BE TAKEN TO ASSURE A UNIFORM GRADE ON THE RAMP, FREE OF SAGS AND SHORT GRADE CHANGES.
3. DRAINAGE STRUCTURES SHOULD NOT BE PLACED IN LINE WITH THE RAMP. LOCATION OF THE HANDICAP RAMP SHOULD TAKE PRECEDENCE OVER LOCATION OF NEW STORM DRAINAGE STRUCTURE INSTALLATIONS.
4. THE NORMAL GUTTER LINE PROFILE SHALL BE MAINTAINED THROUGH THE AREA OF THE RAMP. RAMP LIP TO BE 1/4" ABOVE THE GUTTER LINE.
5. CROSSWALK AND STOP LINE MARKINGS , IF USED , SHALL BE SO LOCATED TO STOP TRAFFIC SHORT OF RAMP CROSSINGS.
6. TRUNCATED DOMES SHALL BE INSTALLED AT THE BOTTOM 2' OF RAMP, LOCATE THE EDGE OF THE PANEL NO MORE THAN 6" FROM THE BACK OF CURB. RED BRICK COLOR ONLY ON TRUNCATED DOMES.
7. CONCRETE IN RAMP AREAS SHALL BE 6" REINFORCED (24" O.C) USING 4,000 PSI MIX (MIN. 6.5 SACK).
8. ALL 6" REINFORCED CONCRETE IN RAMP AREAS SHALL BE DOWELED INTO CURB AND GUTTER (18" O.C.)
9. DOWEL INTO EXISTING CONCRETE AS DIRECTED BY CITY ENGINEER'S OFFICE.
10. DOWELS SHALL BE #3 STRAIGHT (SMOOTH) BAR WITH A MIN. LENGTH OF 12" MIN. EMBED DEPTH SHALL BE 3"
11. ACI CERTIFICATION IS REQUIRED FOR PLACING AND FINISHING CONCRETE IN THE RIGHT-OF-WAY.

## HANDICAP RAMP – MID BLOCK (BOULEVARD)

OFFICE OF CITY ENGINEER  
GREAT FALLS, MONTANA

REVISED: SEPTEMBER 2023

5 - 17A

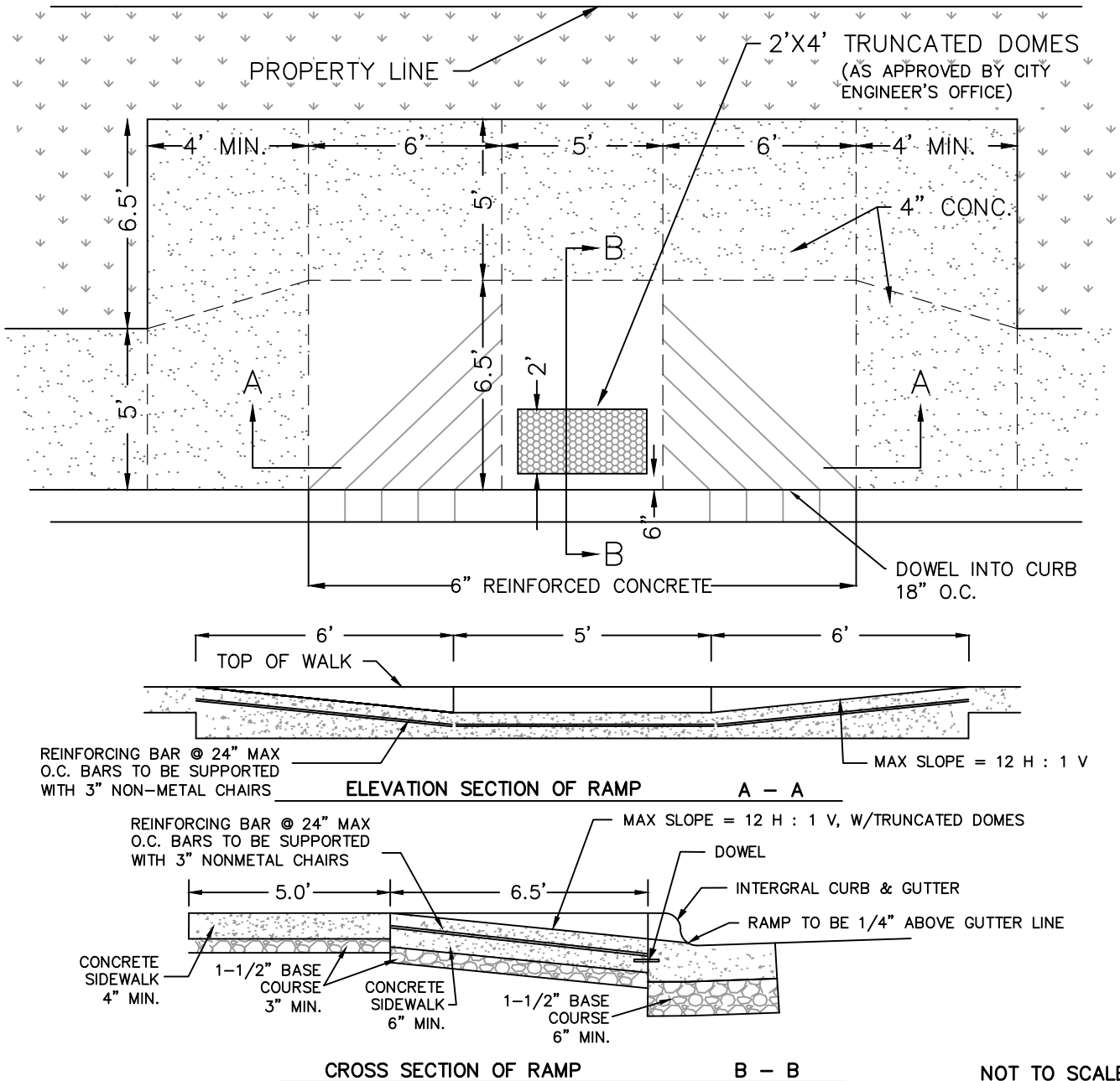

**NOTES :**

1. SURFACE TEXTURE OF RAMP SHALL BE THAT OBTAINED BY A COARSE BROOMING TRAVERSE TO THE SLOPE OF THE RAMP.
2. CARE SHALL BE TAKEN TO ASSURE A UNIFORM GRADE ON THE RAMP, FREE OF SAGS AND SHORT GRADE CHANGES.
3. DRAINAGE STRUCTURES SHOULD NOT BE PLACED IN LINE WITH THE RAMP. LOCATION OF THE HANDICAP RAMP SHOULD TAKE PRECEDENCE OVER LOCATION OF NEW STORM DRAINAGE STRUCTURE INSTALLATIONS.
4. THE NORMAL GUTTER LINE PROFILE SHALL BE MAINTAINED THROUGH THE AREA OF THE RAMP. RAMP LIP TO BE 1/4" ABOVE THE GUTTER LINE.
5. CROSSWALK AND STOP LINE MARKINGS, IF USED, SHALL BE SO LOCATED TO STOP TRAFFIC SHORT OF RAMP CROSSINGS.
6. TRUNCATED DOMES SHALL BE INSTALLED AT THE BOTTOM 2' OF RAMPS. WIDTH OF RAMPS MAY VARY. BRICK RED COLOR ONLY ON CONCRETE TRUNCATED DOMES.
7. CONCRETE IN RAMP AREAS SHALL BE 6" REINFORCED (24" O.C) USING 4,000 PSI MIX (MIN. 6.5 SACK).
8. ALL 6" REINFORCED CONCRETE IN RAMP AREAS SHALL BE DOWELED INTO CURB AND GUTTER (18" O.C.)
9. DOWEL INTO EXISTING CONCRETE AS DIRECTED BY CITY ENGINEER'S OFFICE.
10. DOWELS SHALL BE #3 STRAIGHT (SMOOTH) BAR WITH A MIN. LENGTH OF 12" MIN. EMBED DEPTH SHALL BE 3"
11. ACI CERTIFICATION IS REQUIRED FOR PLACING AND FINISHING CONCRETE IN THE RIGHT-OF-WAY.

## HANDICAP RAMP – MID BLOCK (SIDEWALK ADJACENT TO CURB, OFFSET LANDING)

OFFICE OF CITY ENGINEER  
GREAT FALLS, MONTANA

REVISED: SEPTEMBER 2023

5 – 17B

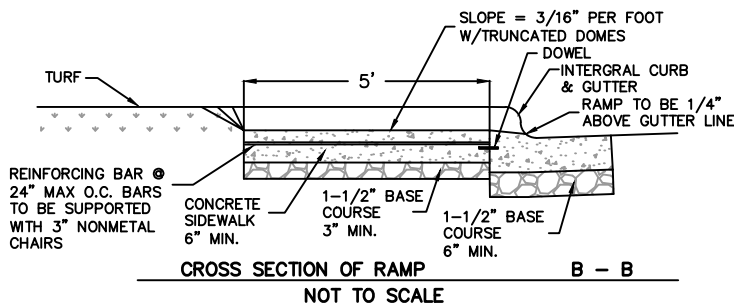
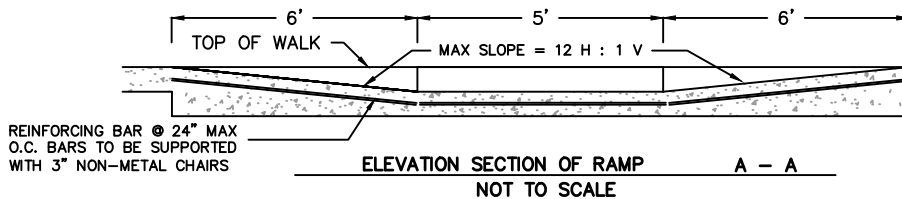
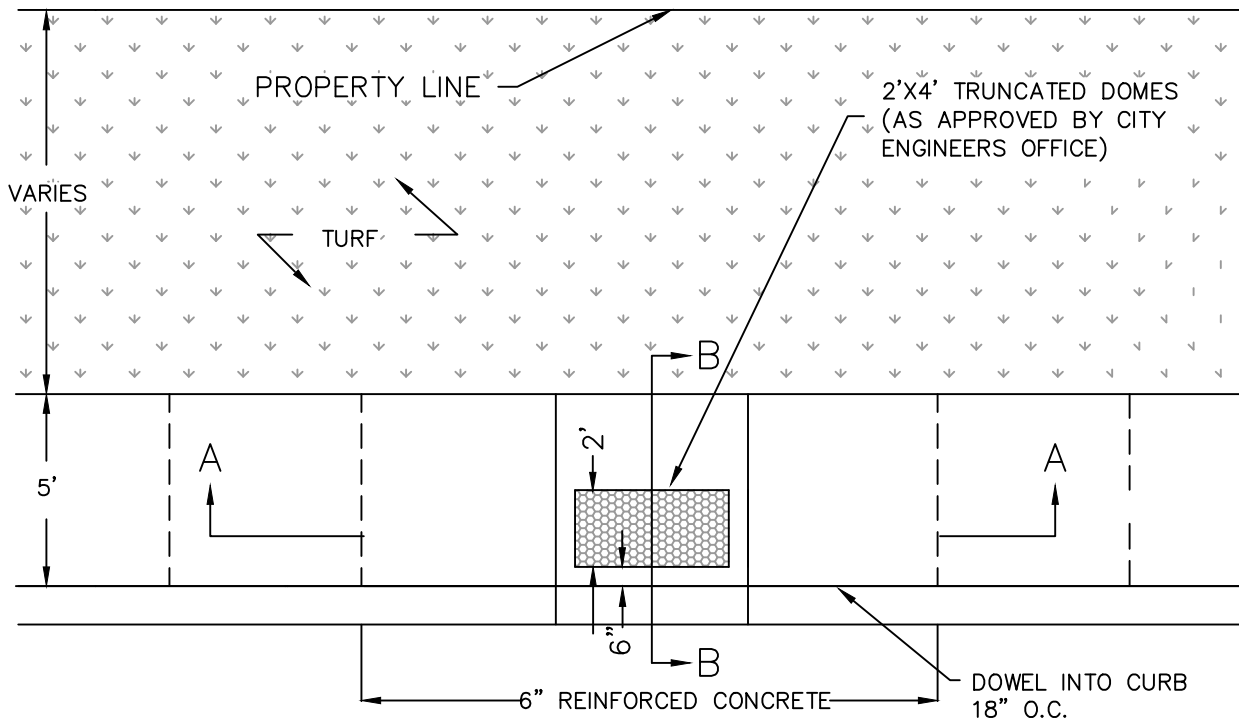

**NOTES :**

1. SURFACE TEXTURE OF RAMP SHALL BE THAT OBTAINED BY A COARSE BROOMING TRAVERSE TO THE SLOPE OF THE RAMP.
2. CARE SHALL BE TAKEN TO ASSURE A UNIFORM GRADE ON THE RAMP, FREE OF SAGS AND SHORT GRADE CHANGES.
3. DRAINAGE STRUCTURES SHOULD NOT BE PLACED IN LINE WITH THE RAMP. LOCATION OF THE HANDICAP RAMP SHOULD TAKE PRECEDENCE OVER LOCATION OF NEW STORM DRAINAGE STRUCTURE INSTALLATIONS.
4. THE NORMAL GUTTER LINE PROFILE SHALL BE MAINTAINED THROUGH THE AREA OF THE RAMP. RAMP LIP TO BE 1/4" ABOVE THE GUTTER LINE.
5. CROSSWALK AND STOP LINE MARKINGS, IF USED, SHALL BE SO LOCATED TO STOP TRAFFIC SHORT OF RAMP CROSSINGS.
6. TRUNCATED DOMES SHALL BE INSTALLED AT THE BOTTOM 2' OF RAMPS, LOCATE THE EDGE OF THE PANEL NO MORE THAN 6" FROM THE BACK OF CURB. RED BRICK COLOR ONLY ON TRUNCATED DOMES.
7. CONCRETE IN RAMP AREAS SHALL BE 6" REINFORCED (24" O.C) USING 4,000 PSI MIX (MIN. 6.5 SACK).
8. ALL 6" REINFORCED CONCRETE IN RAMP AREAS SHALL BE DOWELED INTO CURB AND GUTTER (18" O.C.)
9. DOWEL INTO EXISTING CONCRETE AS DIRECTED BY CITY ENGINEER'S OFFICE.
10. DOWELS SHALL BE #3 STRAIGHT (SMOOTH) BAR WITH A MIN. LENGTH OF 12" MIN. EMBED DEPTH SHALL BE 3"
11. ACI CERTIFICATION IS REQUIRED FOR PLACING AND FINISHING CONCRETE IN THE RIGHT-OF-WAY.

## HANDICAP RAMP – MID BLOCK (SIDEWALK ADJACENT)

OFFICE OF CITY ENGINEER  
GREAT FALLS, MONTANA

REVISED: SEPTEMBER 2023

5 – 17C

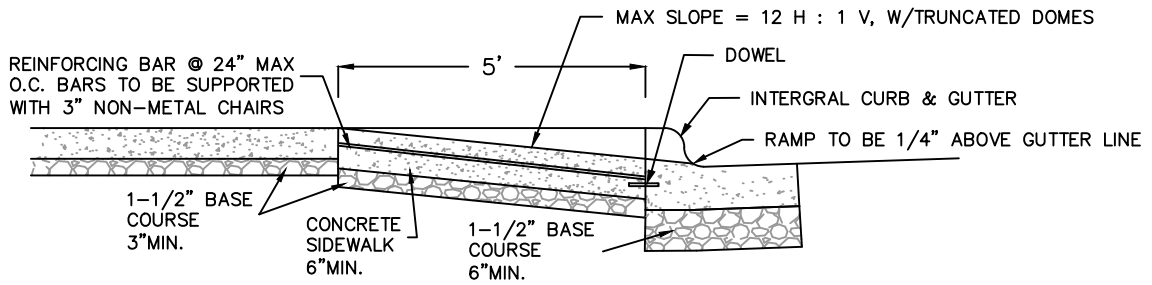
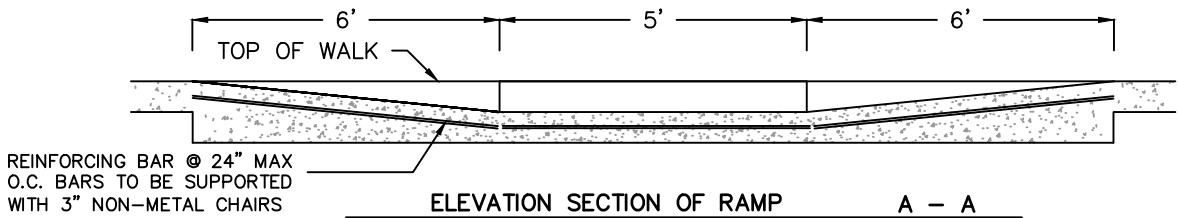
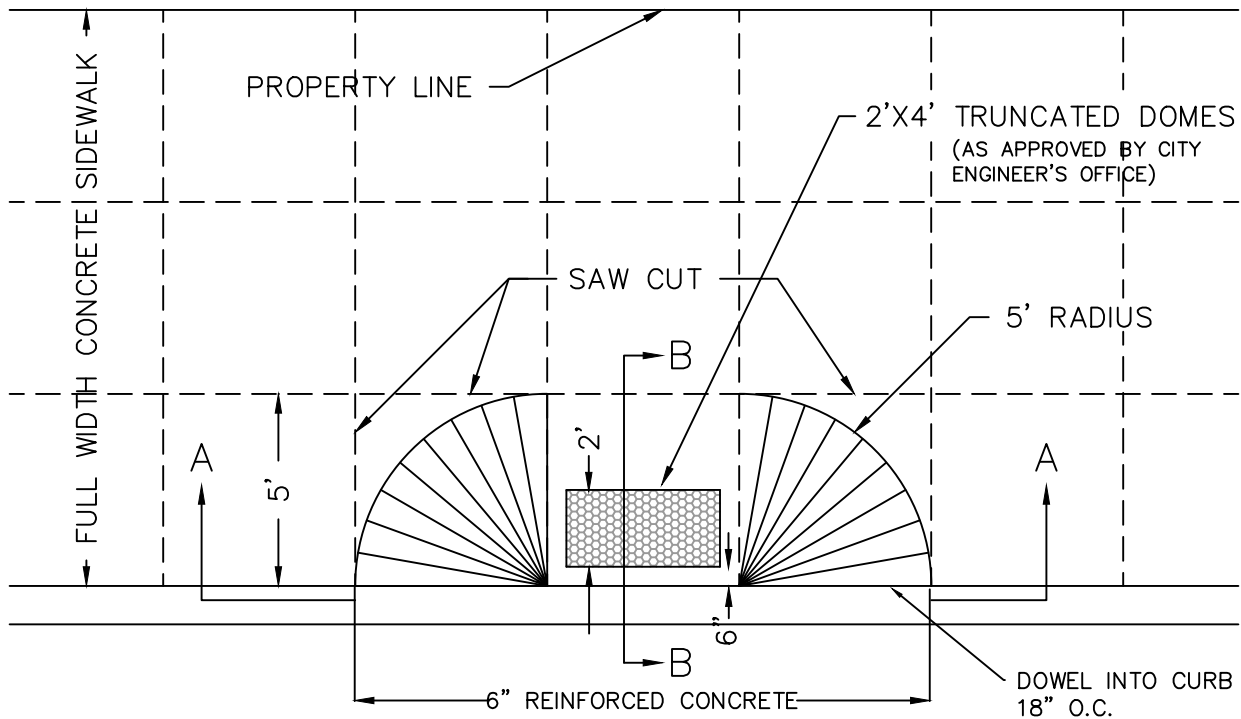

CROSS SECTION OF RAMP

B - B

NOT TO SCALE

NOTES :

1. SURFACE TEXTURE OF RAMP SHALL BE THAT OBTAINED BY A COARSE BROOMING TRAVERSE TO THE SLOPE OF THE RAMP.
2. CARE SHALL BE TAKEN TO ASSURE A UNIFORM GRADE ON THE RAMP, FREE OF SAGS AND SHORT GRADE CHANGES.
3. DRAINAGE STRUCTURES SHOULD NOT BE PLACED IN LINE WITH THE RAMP. LOCATION OF THE HANDICAP RAMP SHOULD TAKE PRECEDENCE OVER LOCATION OF NEW STORM DRAINAGE STRUCTURE INSTALLATIONS.
4. THE NORMAL GUTTER LINE PROFILE SHALL BE MAINTAINED THROUGH THE AREA OF THE RAMP. RAMP LIP TO BE 1/4" ABOVE THE GUTTER LINE.
5. CROSSWALK AND STOP LINE MARKINGS, IF USED, SHALL BE SO LOCATED TO STOP TRAFFIC SHORT OF RAMP CROSSINGS.
6. TRUNCATED DOMES SHALL BE INSTALLED AT THE BOTTOM 2' OF RAMPS. WIDTH OF RAMPS MAY VARY. BRICK RED COLOR ONLY ON TRUNCATED DOMES.
7. CONCRETE IN RAMP AREAS SHALL BE 6" REINFORCED (24" O.C) USING 4,000 PSI MIX (MIN. 6.5 SACK).
8. ALL 6" REINFORCED CONCRETE IN RAMP AREAS SHALL BE DOWELED INTO CURB AND GUTTER (18" O.C.)
9. DOWEL INTO EXISTING CONCRETE AS DIRECTED BY CITY ENGINEER'S OFFICE.
10. DOWELS SHALL BE #3 STRAIGHT (SMOOTH) BAR WITH A MIN. LENGTH OF 12" MIN. EMBED DEPTH SHALL BE 3"
11. ACI CERTIFICATION IS REQUIRED FOR PLACING AND FINISHING CONCRETE IN THE RIGHT-OF-WAY.

## HANDICAP RAMP - MID BLOCK

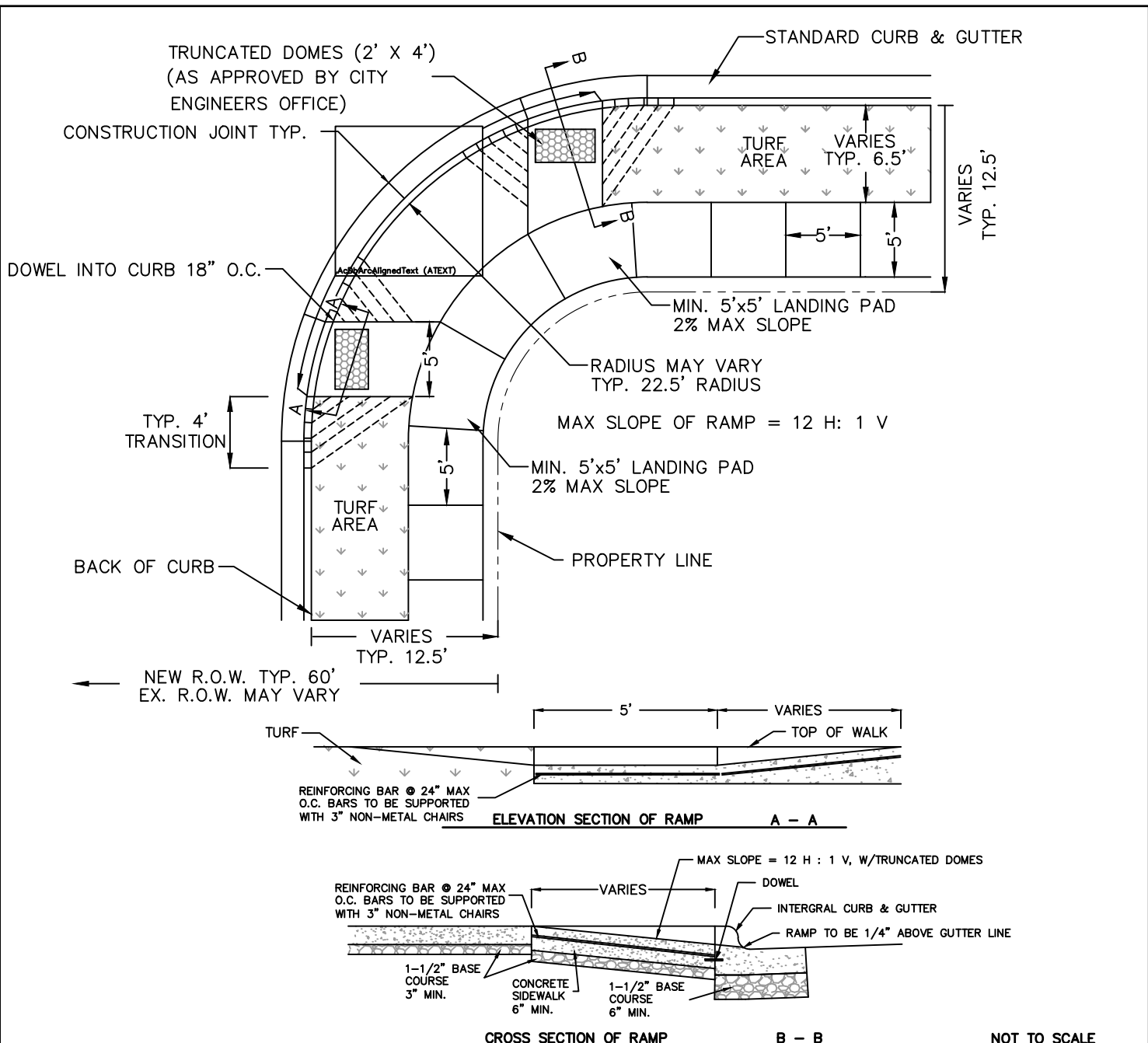

**NOTES :**

1. SURFACE TEXTURE OF RAMP SHALL BE THAT OBTAINED BY A COARSE BROOMING TRAVERSE TO THE SLOPE OF THE RAMP.
2. CARE SHALL BE TAKEN TO ASSURE A UNIFORM GRADE ON THE RAMP, FREE OF SAGS AND SHORT GRADE CHANGES.
3. DRAINAGE STRUCTURES SHOULD NOT BE PLACED IN LINE WITH THE RAMP. LOCATION OF THE HANDICAP RAMP SHOULD TAKE PRECEDENCE OVER LOCATION OF NEW STORM DRAINAGE STRUCTURE INSTALLATIONS.
4. THE NORMAL GUTTER LINE PROFILE SHALL BE MAINTAINED THROUGH THE AREA OF THE RAMP. RAMP LIP TO BE 1/4" ABOVE THE GUTTER LINE.
5. CROSSWALK AND STOP LINE MARKINGS, IF USED, SHALL BE SO LOCATED TO STOP TRAFFIC SHORT OF RAMP CROSSINGS.
6. THE DESIGN ENGINEER SHALL ENSURE ALL INTERSECTION RAMPS ARE DESIGNED IN CONFORMANCE WITH ADA REQUIREMENTS.
7. TRUNCATED DOMES SHALL BE INSTALLED AT THE BOTTOM 2' OF RAMPS. WIDTH OF RAMPS MAY VARY. BRICK RED COLOR ONLY ON TRUNCATED DOMES.
8. CONCRETE IN RAMP AREAS SHALL BE 6" REINFORCED (24" O.C) USING 4,000 PSI MIX (MIN. 6.5 SACK).
9. ALL 6" REINFORCED CONCRETE IN RAMP AREAS SHALL BE DOWELED INTO CURB AND GUTTER (18" O.C.)
10. DOWEL INTO EXISTING CONCRETE AS DIRECTED BY CITY ENGINEER'S OFFICE.
11. DOWELS SHALL BE #3 STRAIGHT (SMOOTH) BAR WITH A MIN. LENGTH OF 12" MIN. EMBED DEPTH SHALL BE 3"
12. ACI CERTIFICATION IS REQUIRED FOR PLACING AND FINISHING CONCRETE IN THE RIGHT-OF-WAY.

## DOUBLE HANDICAP RAMPS AT ROUNDED SIDEWALK BOULEVARD AREAS

OFFICE OF CITY ENGINEER  
GREAT FALLS, MONTANA

REVISED: OCTOBER 2023

5 - 19

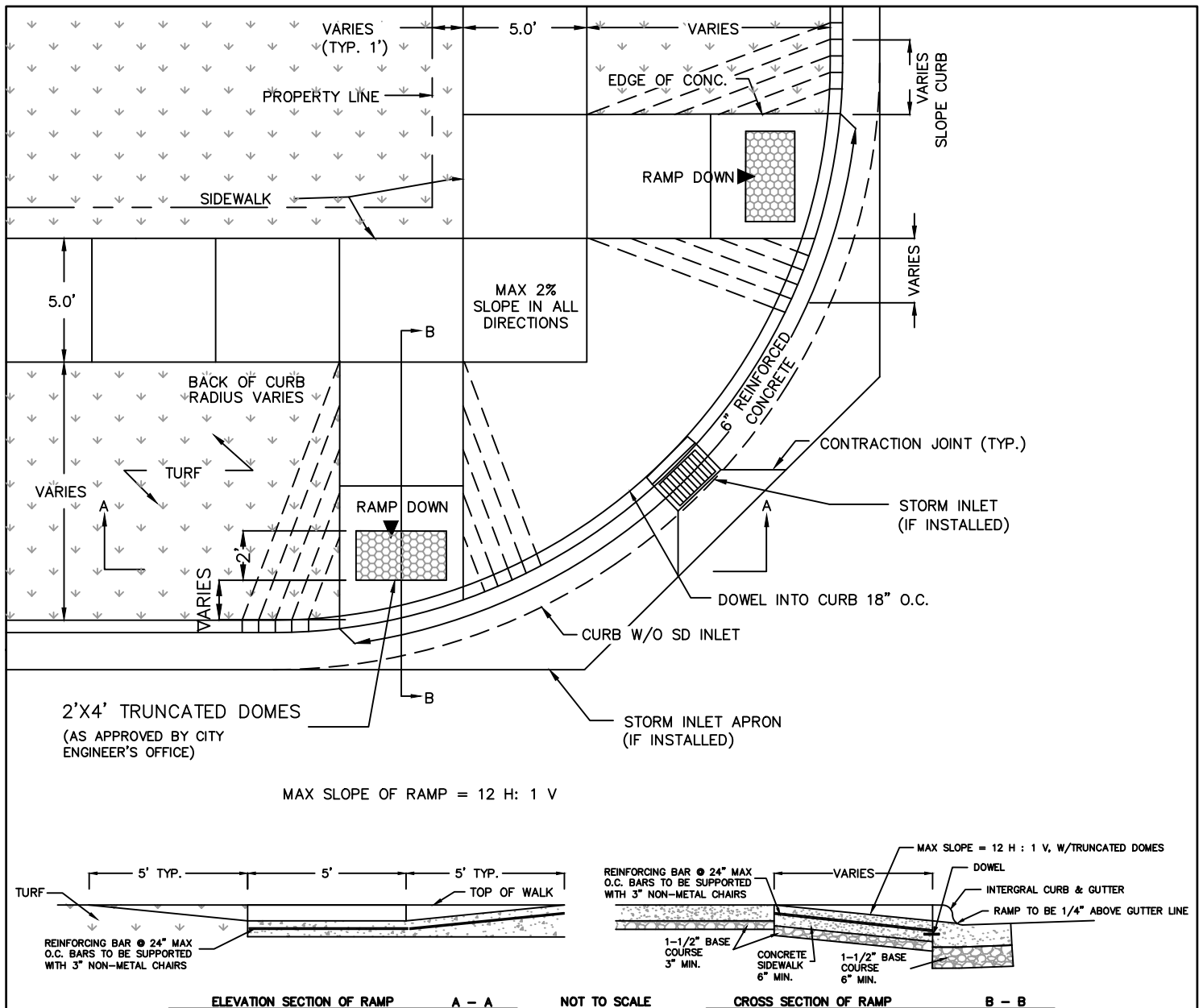

**NOTES :**

1. SURFACE TEXTURE OF RAMP SHALL BE THAT OBTAINED BY A COARSE BROOMING TRAVERSE TO THE SLOPE OF THE RAMP.
2. CARE SHALL BE TAKEN TO ASSURE A UNIFORM GRADE ON THE RAMP, FREE OF SAGS AND SHORT GRADE CHANGES.
3. DRAINAGE STRUCTURES SHOULD NOT BE PLACED IN LINE WITH THE RAMP. LOCATION OF THE HANDICAP RAMP SHOULD TAKE PRECEDENCE OVER LOCATION OF NEW STORM DRAINAGE STRUCTURE INSTALLATIONS.
4. THE NORMAL GUTTER LINE PROFILE SHALL BE MAINTAINED THROUGH THE AREA OF THE RAMP. RAMP LIP TO BE 1/4" ABOVE THE GUTTER LINE.
5. CROSSWALK AND STOP LINE MARKINGS, IF USED, SHALL BE SO LOCATED TO STOP TRAFFIC SHORT OF RAMP CROSSINGS.
6. THE DESIGN ENGINEER SHALL ENSURE ALL INTERSECTION RAMPS ARE DESIGNED IN CONFORMANCE WITH ADA REQUIREMENTS.
7. TRUNCATED DOMES SHALL BE INSTALLED AT THE BOTTOM 2' OF RAMPS. WIDTH OF RAMPS MAY VARY. BRICK RED COLOR ONLY ON TRUNCATED DOMES.
8. CONCRETE IN RAMP AREAS SHALL BE 6" REINFORCED (24" O.C) USING 4,000 PSI MIX (MIN. 6.5 SACK).
9. ALL 6" REINFORCED CONCRETE IN RAMPS AREAS SHALL BE DOWELED INTO CURB AND GUTTER (18" O.C.)
10. DOWEL INTO EXISTING CONCRETE AS DIRECTED BY CITY ENGINEER'S OFFICE.
11. DOWELS SHALL BE #3 STRAIGHT (SMOOTH) BAR WITH A MIN. LENGTH OF 12" MIN. EMBED DEPTH SHALL BE 3"
12. ACI CERTIFICATION IS REQUIRED FOR PLACING AND FINISHING CONCRETE IN THE RIGHT-OF-WAY.

## DOUBLE HANDICAP RAMPS AT CORNERS IN BOULEVARD AREAS

OFFICE OF CITY ENGINEER  
GREAT FALLS, MONTANA

REVISED: OCTOBER 2023

5 - 20



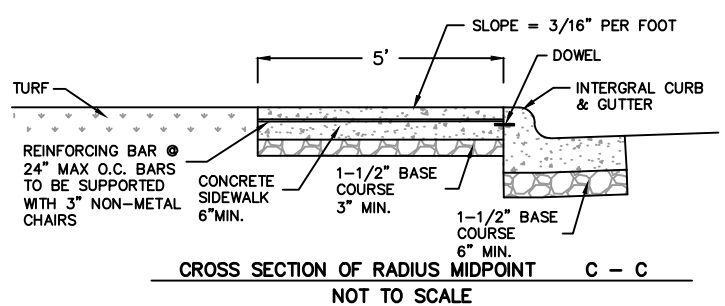
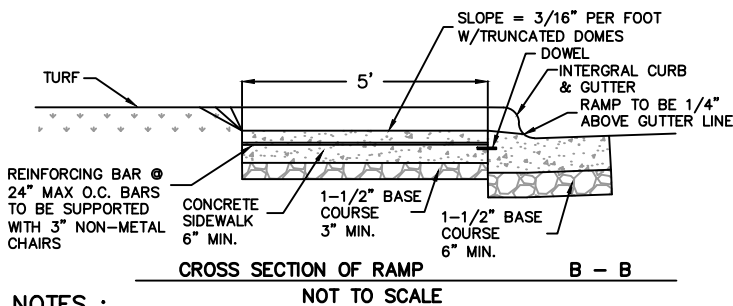
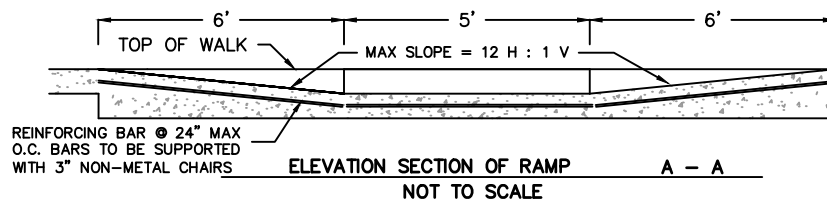
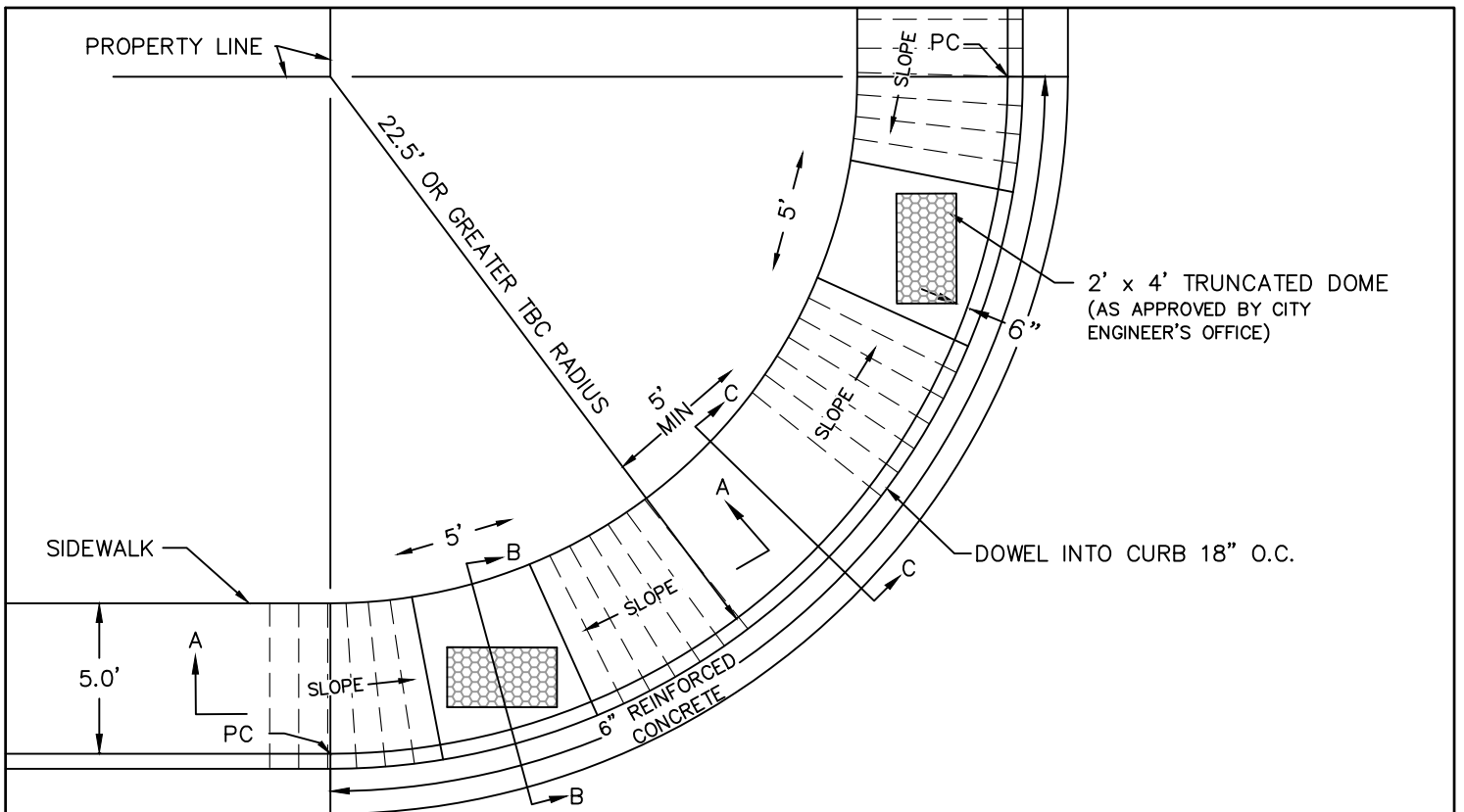

**NOTES :**

1. SURFACE TEXTURE OF RAMP SHALL BE THAT OBTAINED BY A COARSE BROOMING TRAVERSE TO THE SLOPE OF THE RAMP.
2. CARE SHALL BE TAKEN TO ASSURE A UNIFORM GRADE ON THE RAMP, FREE OF SAGS AND SHORT GRADE CHANGES.
3. DRAINAGE STRUCTURES SHOULD NOT BE PLACED IN LINE WITH THE RAMP. LOCATION OF THE HANDICAP RAMP SHOULD TAKE PRECEDENCE OVER LOCATION OF NEW STORM DRAINAGE STRUCTURE INSTALLATIONS.
4. THE NORMAL GUTTER LINE PROFILE SHALL BE MAINTAINED THROUGH THE AREA OF THE RAMP. RAMP LIP TO BE 1/4" ABOVE THE GUTTER LINE.
5. CROSSWALK AND STOP LINE MARKINGS, IF USED, SHALL BE SO LOCATED TO STOP TRAFFIC SHORT OF RAMP CROSSINGS.
6. THE DESIGN ENGINEER SHALL ENSURE ALL INTERSECTION RAMPS ARE DESIGNED IN CONFORMANCE WITH ADA REQUIREMENTS.
7. TRUNCATED DOMES SHALL BE INSTALLED AT THE BOTTOM 2' OF RAMPS. WIDTH OF RAMPS MAY VARY. BRICK RED COLOR ONLY ON TRUNCATED DOMES.
8. CONCRETE IN RAMP AREAS SHALL BE 6" REINFORCED (24" O.C) USING 4,000 PSI MIX (MIN. 6.5 SACK).
9. ALL 6" REINFORCED CONCRETE IN RAMP AREAS SHALL BE DOWELED INTO CURB AND GUTTER (18" O.C.)
10. DOWEL INTO EXISTING CONCRETE AS DIRECTED BY CITY ENGINEER'S OFFICE.
11. DOWELS SHALL BE #3 STRAIGHT (SMOOTH) BAR WITH A MIN. LENGTH OF 12" MIN. EMBED DEPTH SHALL BE 3"
12. ACI CERTIFICATION IS REQUIRED FOR PLACING AND FINISHING CONCRETE IN THE RIGHT-OF-WAY.

**DOUBLE HANDICAP RAMPS WITH SIDEWALK ADJACENT TO CURB**

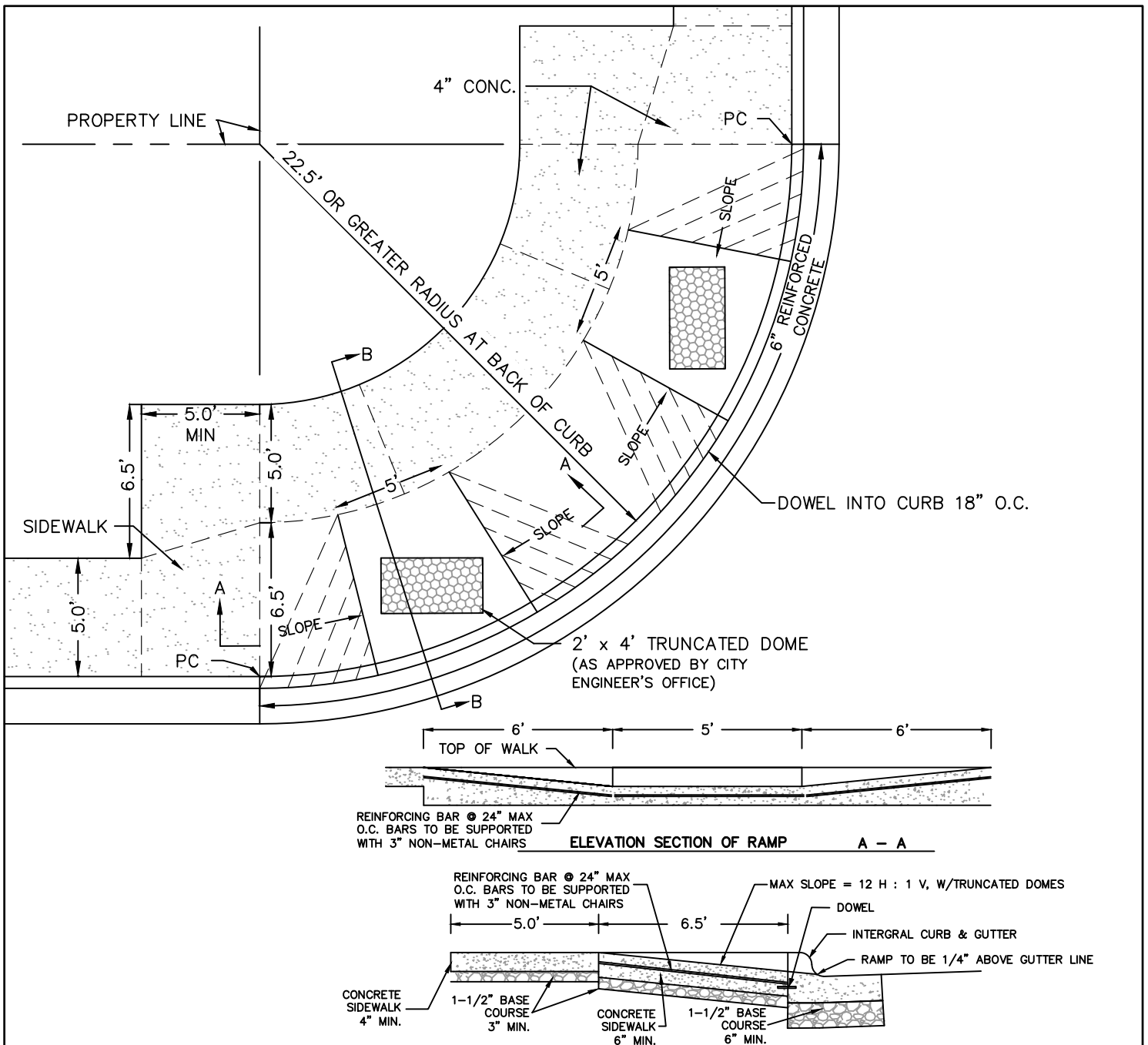

**NOTES :**

1. SURFACE TEXTURE OF RAMP SHALL BE THAT OBTAINED BY A COARSE BROOMING TRAVERSE TO THE SLOPE OF THE RAMP.
2. CARE SHALL BE TAKEN TO ASSURE A UNIFORM GRADE ON THE RAMP, FREE OF SAGS AND SHORT GRADE CHANGES.
3. DRAINAGE STRUCTURES SHOULD NOT BE PLACED IN LINE WITH THE RAMP. LOCATION OF THE HANDICAP RAMP SHOULD TAKE PRECEDENCE OVER LOCATION OF NEW STORM DRAINAGE STRUCTURE INSTALLATIONS.
4. THE NORMAL GUTTER LINE PROFILE SHALL BE MAINTAINED THROUGH THE AREA OF THE RAMP. RAMP LIP TO BE 1/4" ABOVE THE GUTTER LINE.
5. CROSSWALK AND STOP LINE MARKINGS , IF USED , SHALL BE SO LOCATED TO STOP TRAFFIC SHORT OF RAMP CROSSINGS.
6. THE DESIGN ENGINEER SHALL ENSURE ALL INTERSECTION RAMPS ARE DESIGNED IN CONFORMANCE WITH ADA REQUIREMENTS.
7. TRUNCATED DOMES SHALL BE INSTALLED AT THE BOTTOM 2' OF RAMPS. WIDTH OF RAMPS MAY VARY. BRICK RED COLOR ONLY ON CONCRETE TRUNCATED DOMES.
8. CONCRETE IN RAMP AREAS SHALL BE 6" REINFORCED (24" O.C) USING 4,000 PSI MIX (MIN. 6.5 SACK).
9. ALL 6" REINFORCED CONCRETE IN RAMP AREAS SHALL BE DOWELED INTO CURB AND GUTTER (18" O.C.)
10. DOWEL INTO EXISTING CONCRETE AS DIRECTED BY CITY ENGINEER'S OFFICE.
11. DOWELS SHALL BE #3 STRAIGHT (SMOOTH) BAR WITH A MIN. LENGTH OF 12" MIN. EMBED DEPTH SHALL BE 3"
12. ACI CERTIFICATION IS REQUIRED FOR PLACING AND FINISHING CONCRETE IN THE RIGHT-OF-WAY.

**DOUBLE HANDICAP RAMPS WITH SIDEWALK ADJACENT TO CURB**

OFFICE OF CITY ENGINEER  
GREAT FALLS, MONTANA

REVISED: OCTOBER 2023

5 - 21B

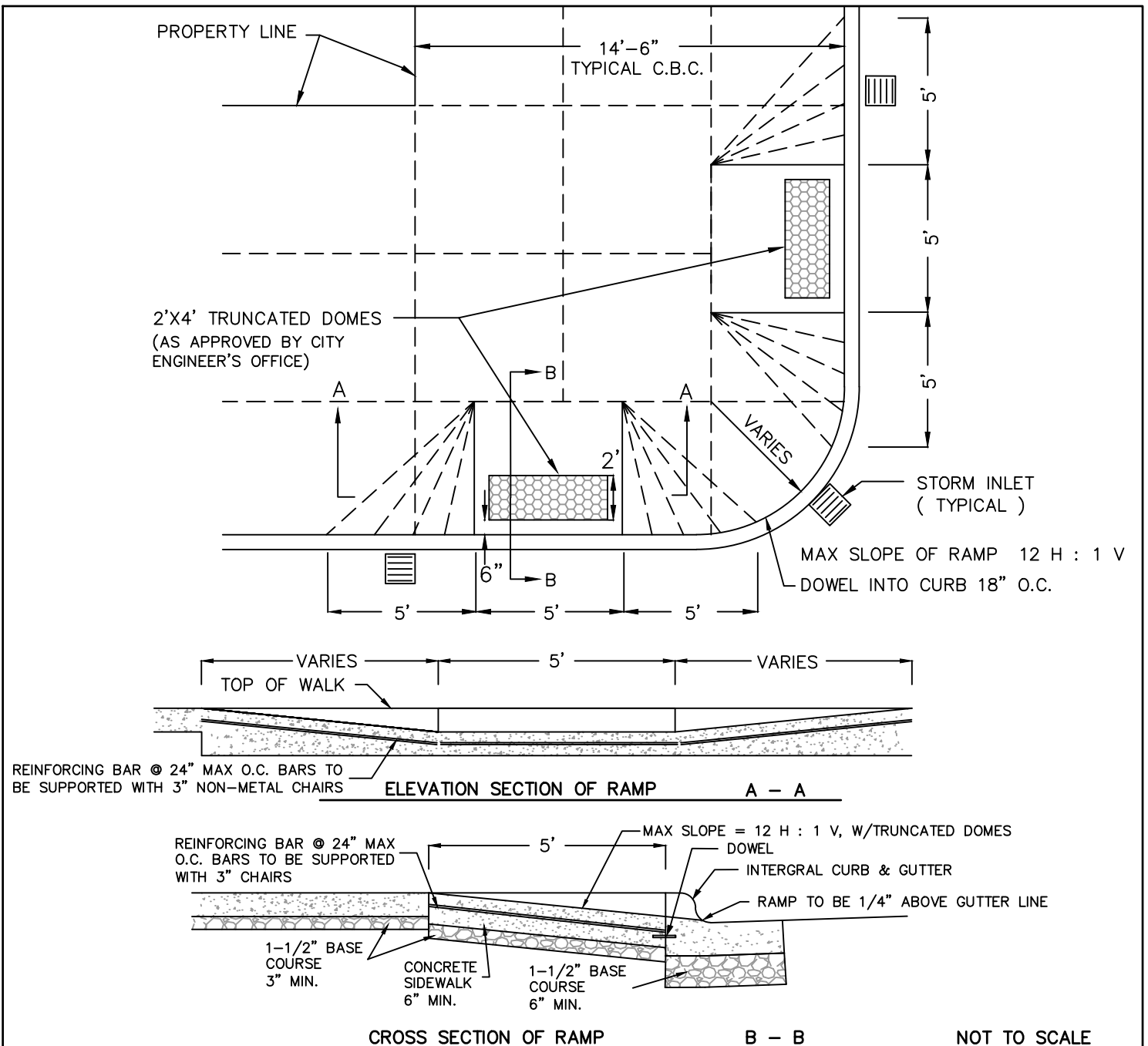

NOTES :

1. SURFACE TEXTURE OF RAMP SHALL BE THAT OBTAINED BY A COARSE BROOMING TRAVERSE TO THE SLOPE OF THE RAMP.
2. CARE SHALL BE TAKEN TO ASSURE A UNIFORM GRADE ON THE RAMP, FREE OF SAGS AND SHORT GRADE CHANGES.
3. DRAINAGE STRUCTURES SHOULD NOT BE PLACED IN LINE WITH THE RAMP. LOCATION OF THE HANDICAP RAMP SHOULD TAKE PRECEDENCE OVER LOCATION OF NEW STORM DRAINAGE STRUCTURE INSTALLATIONS.
4. THE NORMAL GUTTER LINE PROFILE SHALL BE MAINTAINED THROUGH THE AREA OF THE RAMP. RAMP LIP TO BE 1/4" ABOVE THE GUTTER LINE.
5. CROSSWALK AND STOP LINE MARKINGS, IF USED, SHALL BE SO LOCATED TO STOP TRAFFIC SHORT OF RAMP CROSSINGS.
6. THE DESIGN ENGINEER SHALL ENSURE ALL INTERSECTION RAMPS ARE DESIGNED IN CONFORMANCE WITH ADA REQUIREMENTS.
7. TRUNCATED DOMES SHALL BE INSTALLED AT THE BOTTOM 2' OF RAMPS. WIDTH OF RAMPS MAY VARY. BRICK RED COLOR ONLY ON TRUNCATED DOMES.
8. CONCRETE IN RAMP AREAS SHALL BE 6" REINFORCED (24" O.C) USING 4,000 PSI MIX (MIN. 6.5 SACK).
9. ALL 6" REINFORCED CONCRETE IN RAMP AREAS SHALL BE DOWELED INTO CURB AND GUTTER (18" O.C.)
10. DOWEL INTO EXISTING CONCRETE AS DIRECTED BY CITY ENGINEER'S OFFICE.
11. DOWELS SHALL BE #3 STRAIGHT (SMOOTH) BAR WITH A MIN. LENGTH OF 12" MIN. EMBED DEPTH SHALL BE 3"
12. ACI CERTIFICATION IS REQUIRED FOR PLACING AND FINISHING CONCRETE IN THE RIGHT-OF-WAY.

## HANDICAP RAMPS – CENTRAL BUSINESS DISTRICT

OFFICE OF CITY ENGINEER  
GREAT FALLS, MONTANA

REVISED: OCTOBER 2023

5 – 22

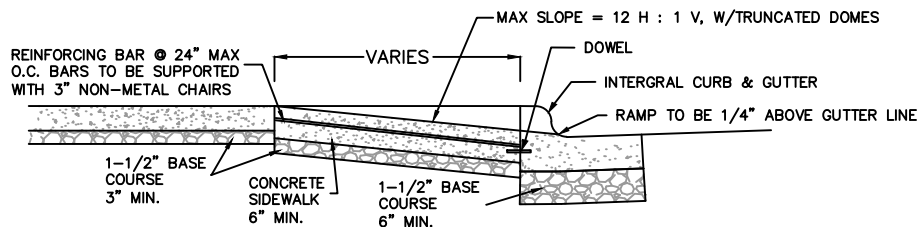
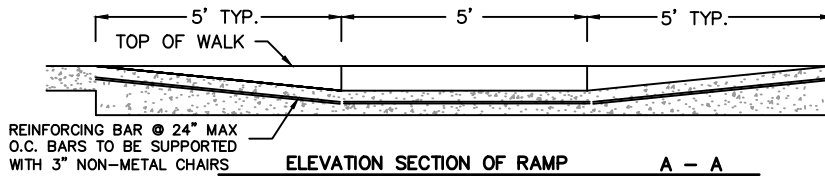
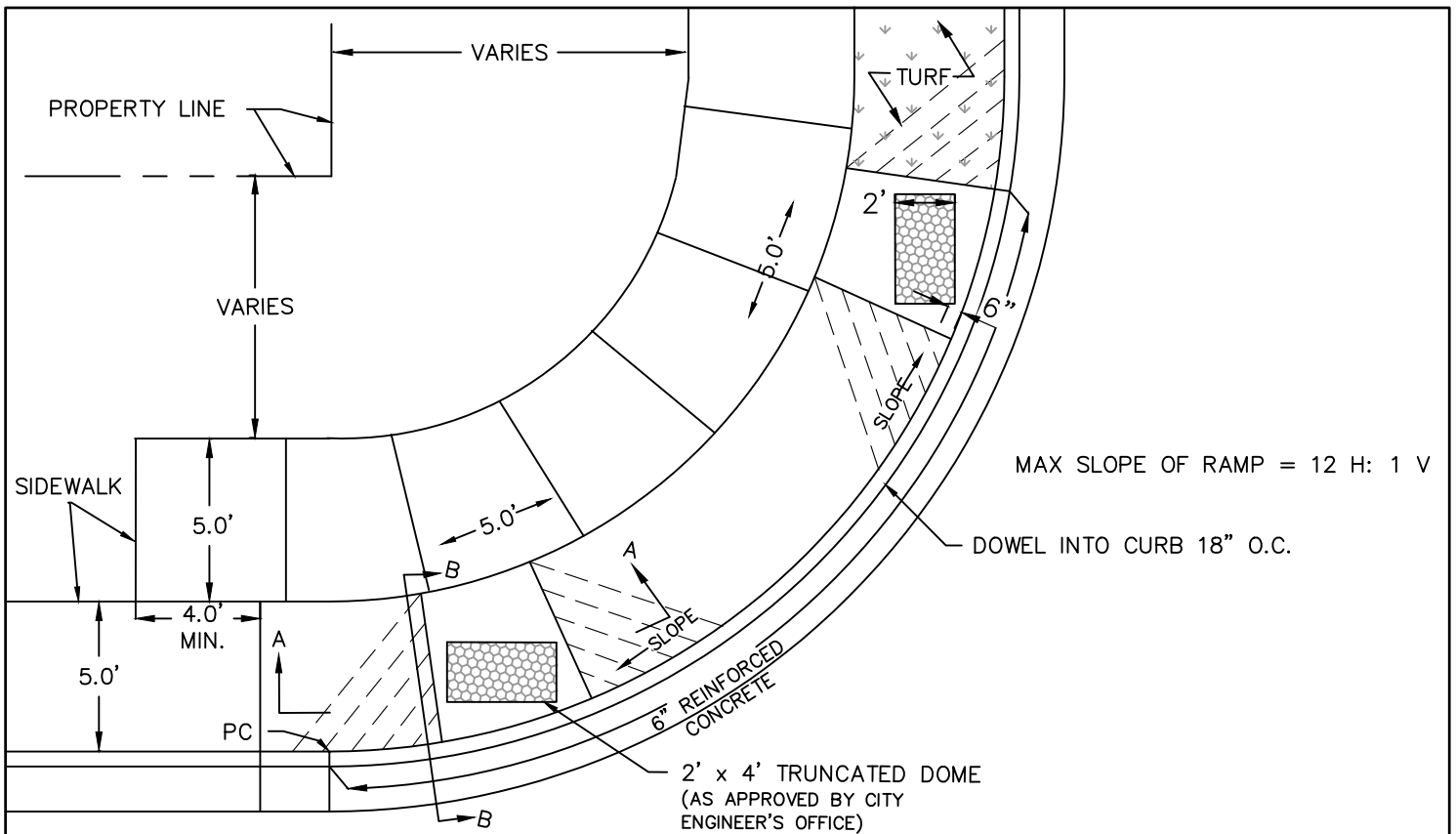

**NOTES :**

1. SURFACE TEXTURE OF RAMP SHALL BE THAT OBTAINED BY A COARSE BROOMING TRAVERSE TO THE SLOPE OF THE RAMP.
2. CARE SHALL BE TAKEN TO ASSURE A UNIFORM GRADE ON THE RAMP, FREE OF SAGS AND SHORT GRADE CHANGES.
3. DRAINAGE STRUCTURES SHOULD NOT BE PLACED IN LINE WITH THE RAMP. LOCATION OF THE HANDICAP RAMP SHOULD TAKE PRECEDENCE OVER LOCATION OF NEW STORM DRAINAGE STRUCTURE INSTALLATIONS.
4. THE NORMAL GUTTER LINE PROFILE SHALL BE MAINTAINED THROUGH THE AREA OF THE RAMP. RAMP LIP TO BE 1/4" ABOVE THE GUTTER LINE.
5. CROSSWALK AND STOP LINE MARKINGS, IF USED, SHALL BE SO LOCATED TO STOP TRAFFIC SHORT OF RAMP CROSSINGS.
6. THE DESIGN ENGINEER SHALL ENSURE ALL INTERSECTION RAMPS ARE DESIGNED IN CONFORMANCE WITH ADA REQUIREMENTS.
7. TRUNCATED DOMES SHALL BE INSTALLED AT THE BOTTOM 2' OF RAMPS. WIDTH OF RAMPS MAY VARY. BRICK RED COLOR ONLY ON TRUNCATED DOMES.
8. CONCRETE IN RAMP AREAS SHALL BE 6" REINFORCED (24" O.C) USING 4,000 PSI MIX (MIN. 6.5 SACK).
9. ALL 6" REINFORCED CONCRETE IN RAMP AREAS SHALL BE DOWELED INTO CURB AND GUTTER (18" O.C.)
10. DOWEL INTO EXISTING CONCRETE AS DIRECTED BY CITY ENGINEER'S OFFICE.
11. DOWELS SHALL BE #3 STRAIGHT (SMOOTH) BAR WITH A MIN. LENGTH OF 12" MIN. EMBED DEPTH SHALL BE 3"
12. ACI CERTIFICATION IS REQUIRED FOR PLACING AND FINISHING CONCRETE IN THE RIGHT-OF-WAY.

## DOUBLE HANDICAP RAMPS WITH SIDEWALK ADJACENT TO CURB AND BOULEVARD AREAS

NOTE : WHERE TRENCH PASSES THROUGH EXISTING PAVEMENT  
 THE PAVEMENT SHALL BE CUT ALONG A NEAT VERTICAL LINE  
 12" FROM THE A/C CUT AT THE EDGE OF THE TRENCH OPENING  
 AFTER RESTORATION OF THE TRENCH BACKFILL.

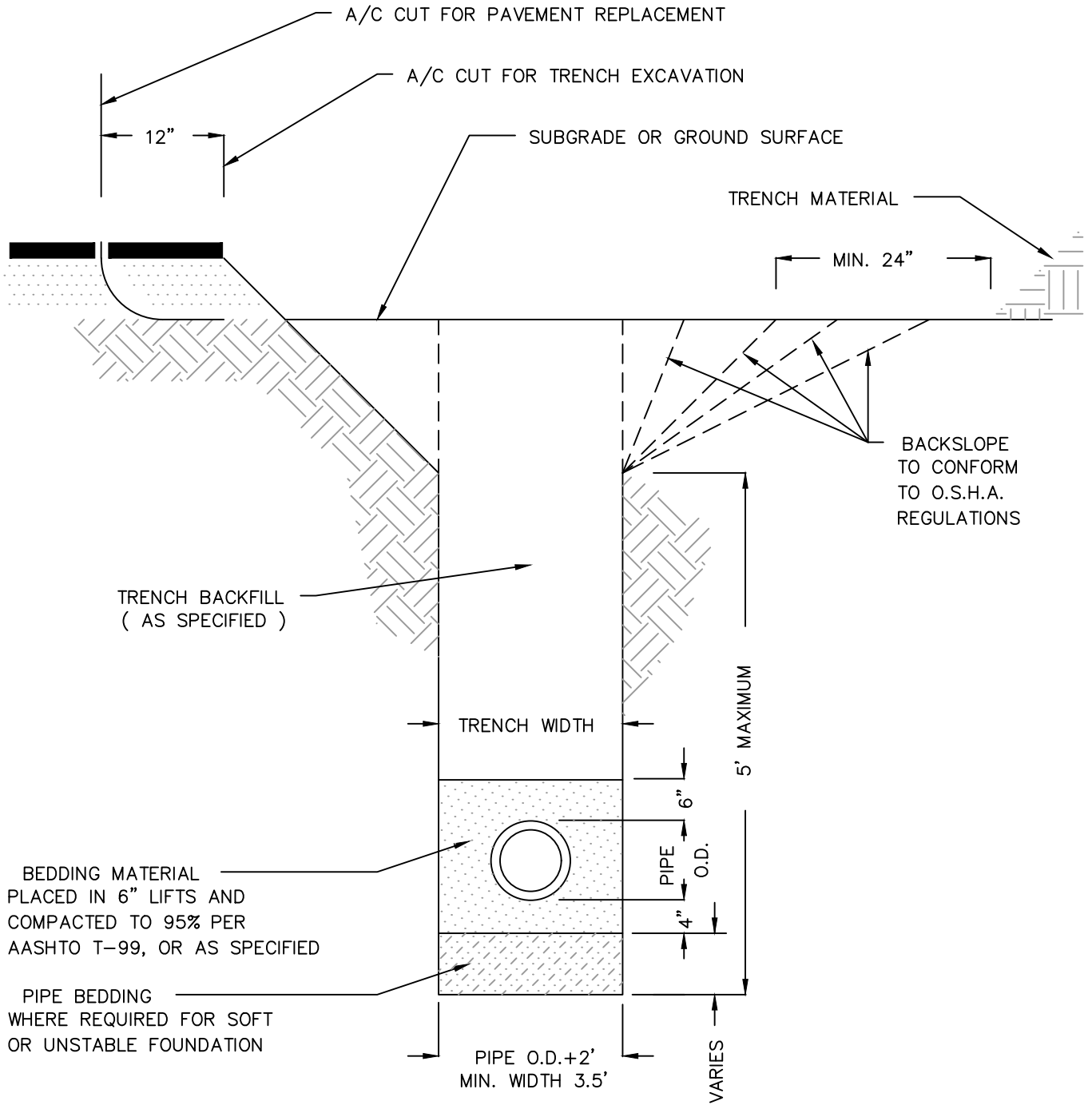

NOTE : WHEN IN UNSTABLE OR SOFT MATERIAL, TRENCH WALLS  
 SHALL BE BACKSLOPED FROM THE BOTTOM OF THE TRENCH

### TYPICAL TYPE 1 TRENCH DETAIL

NOTE : WHERE TRENCH PASSES THROUGH EXISTING PAVEMENT THE PAVEMENT SHALL BE CUT ALONG A NEAT VERTICAL LINE 12" FROM THE A/C CUT AT THE EDGE OF THE TRENCH OPENING AFTER RESORATION OF THE TRENCH BACKFILL.

NOTE : FOR 3' OR LESS OF ASPHALT BETWEEN A/C CUT & CURB (OR EDGE OF ASPHALT ROAD), A/C AND GRAVEL BASE SHALL BE REMOVED TO CURB (OR EDGE OF ASPHALT ROAD).

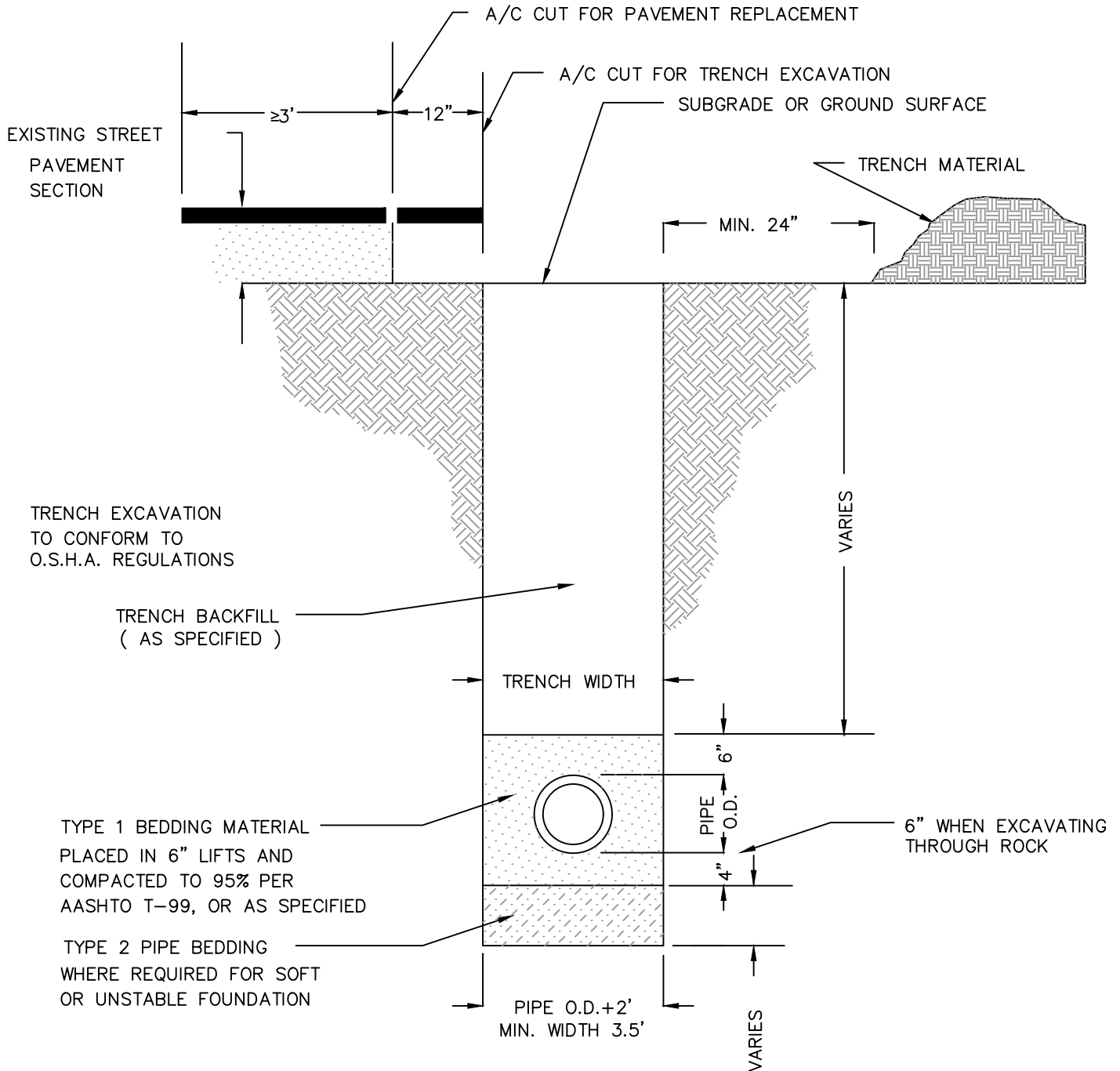

NOTE : IF RCP IS USED FOR THE PIPE, BEDDING IS ONLY NEEDED TO THE SPRINGLINE.

## TYPICAL TYPE 2 TRENCH DETAIL

LINE ON WHICH PAYMENT WILL BE MADE FOR TYPE 1 EXCAVATION

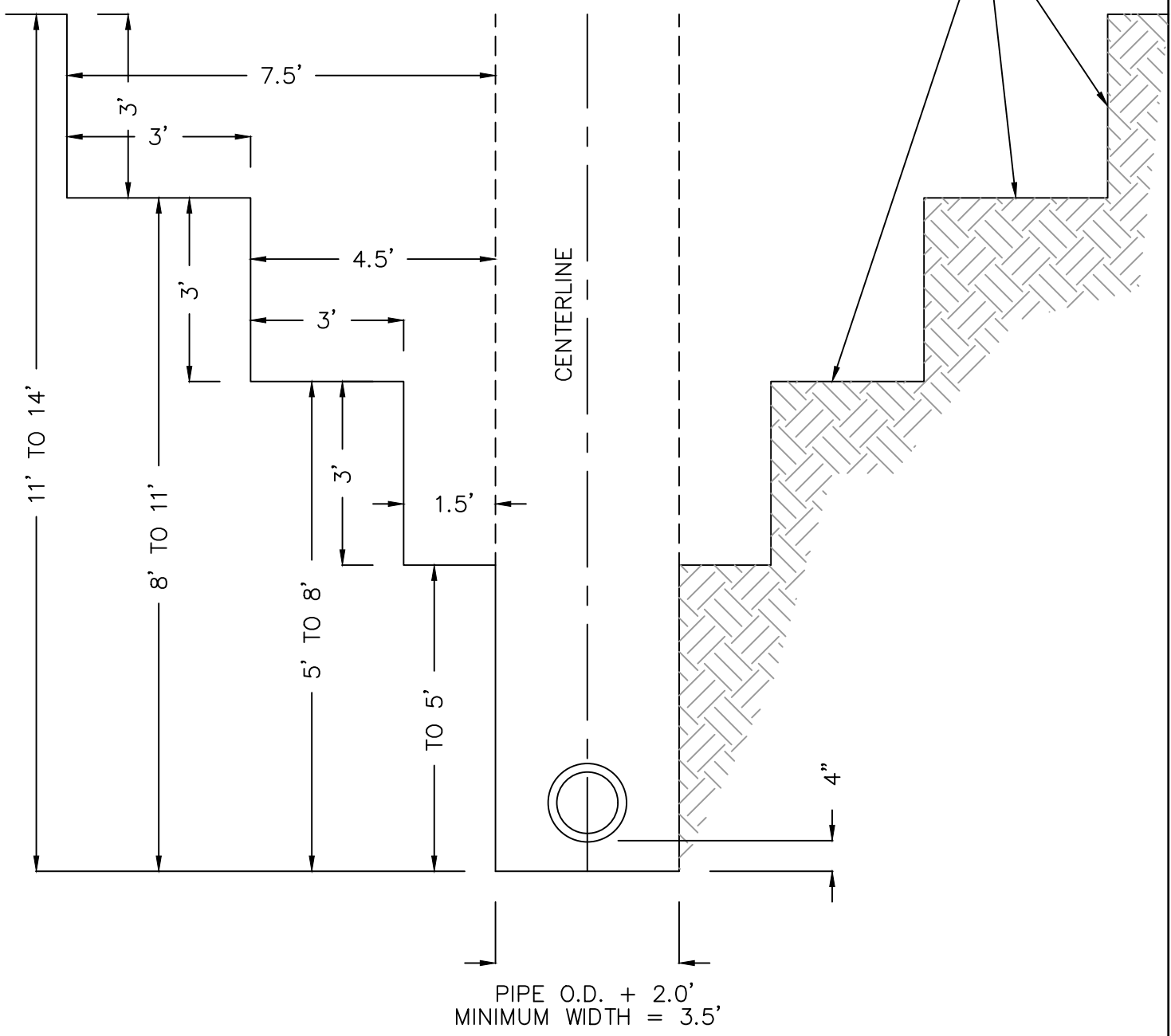

TRENCH DEPTH WILL BE MEASURED ALONG THE CENTERLINE OF THE TRENCH AT DEPTHS EQUAL TO THE VERTICAL DISTANCE FROM THE FINISHED GROUND SURFACE, OR TOP OF PAVEMENT, TO THE FLOW ( INVERT ) LINE OF THE PIPE PLUS THE THICKNESS OF THE PIPE BARREL AND BEDDING MATERIAL.

**TYPE 1 TRENCH – METHOD OF PAYMENT**

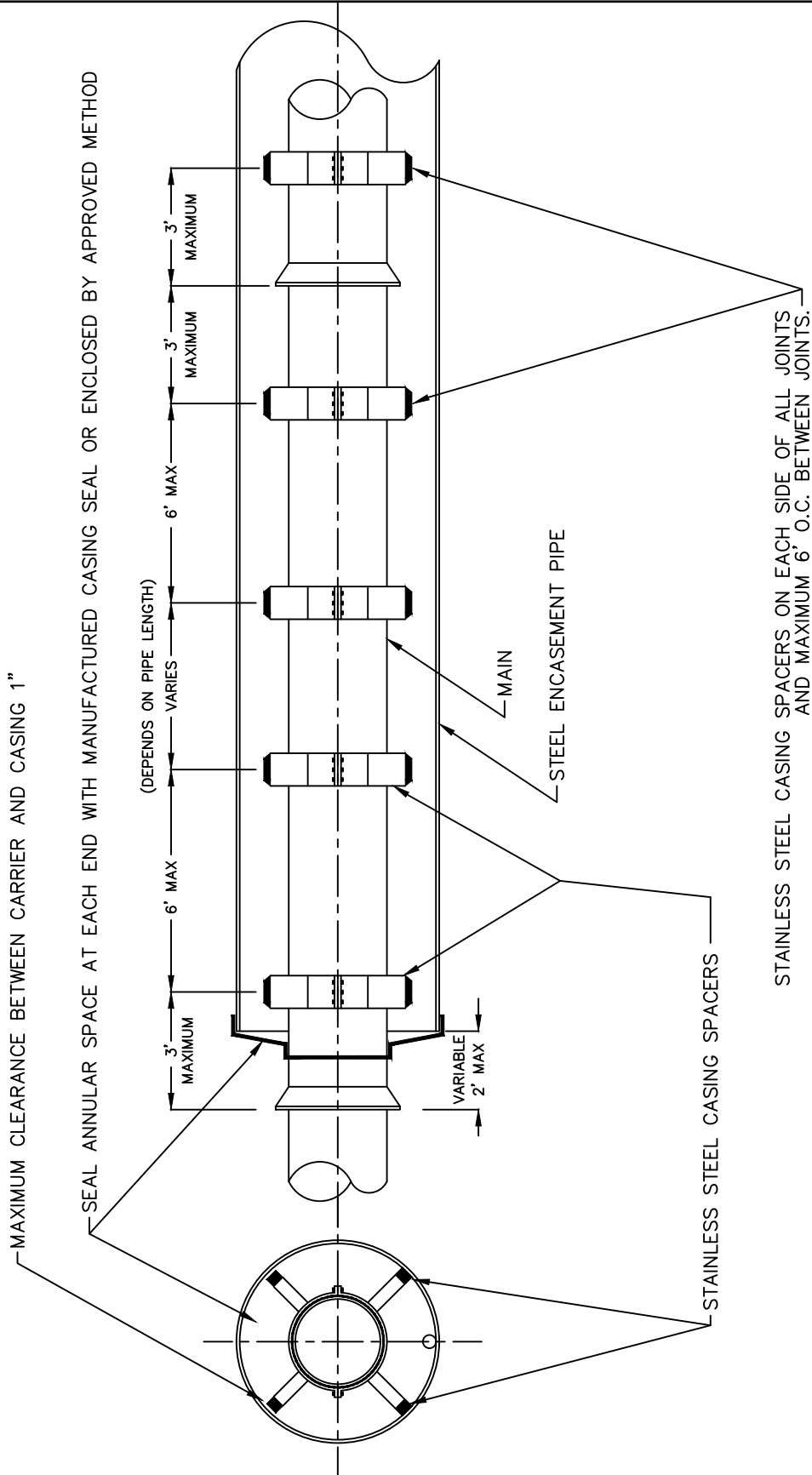

STAINLESS STEEL CASING SPACERS ON EACH SIDE OF ALL JOINTS  
AND MAXIMUM 6' O.C. BETWEEN JOINTS.

### CASING DETAIL



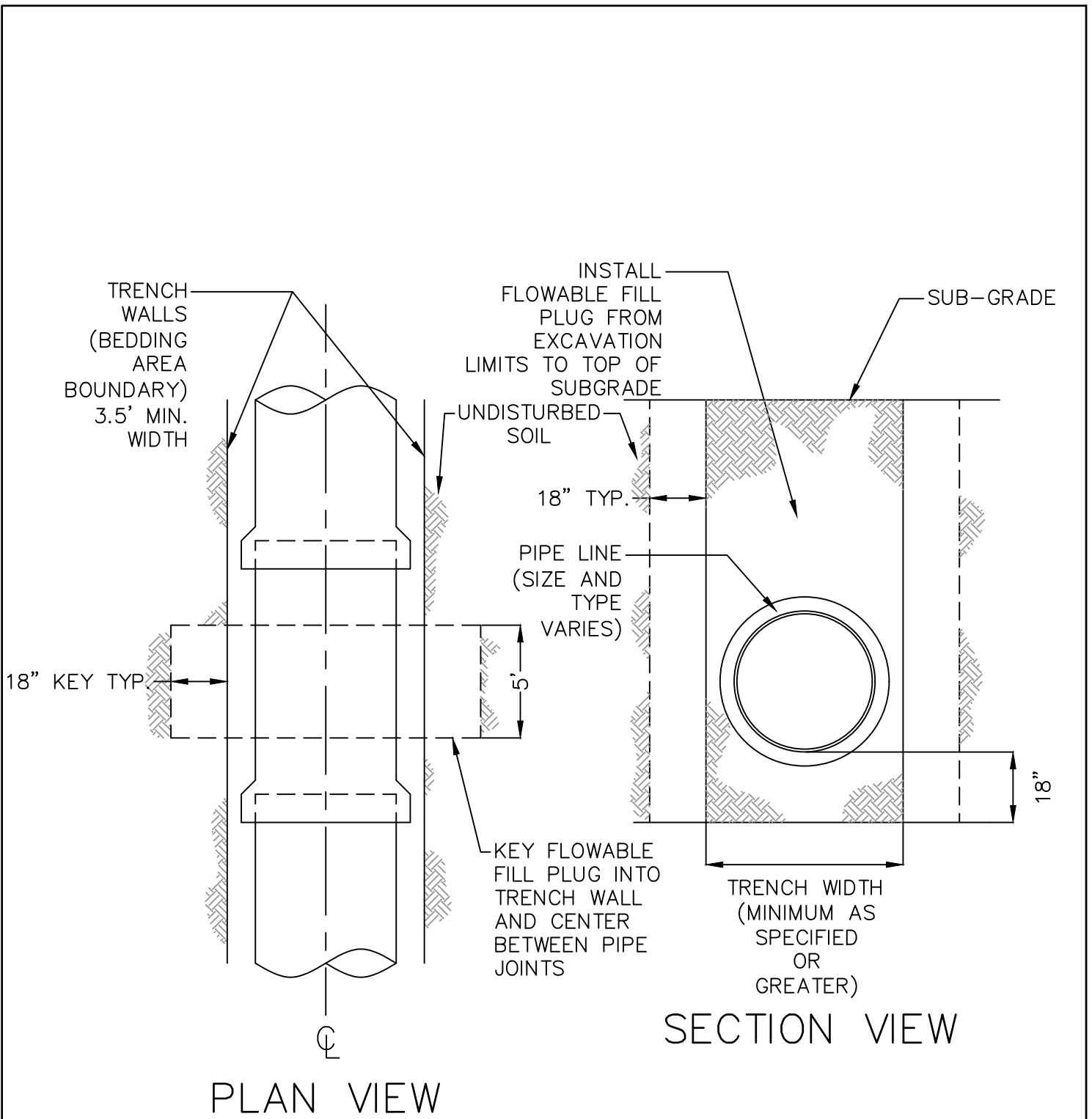

## FLOWABLE FILL TRENCH PLUG

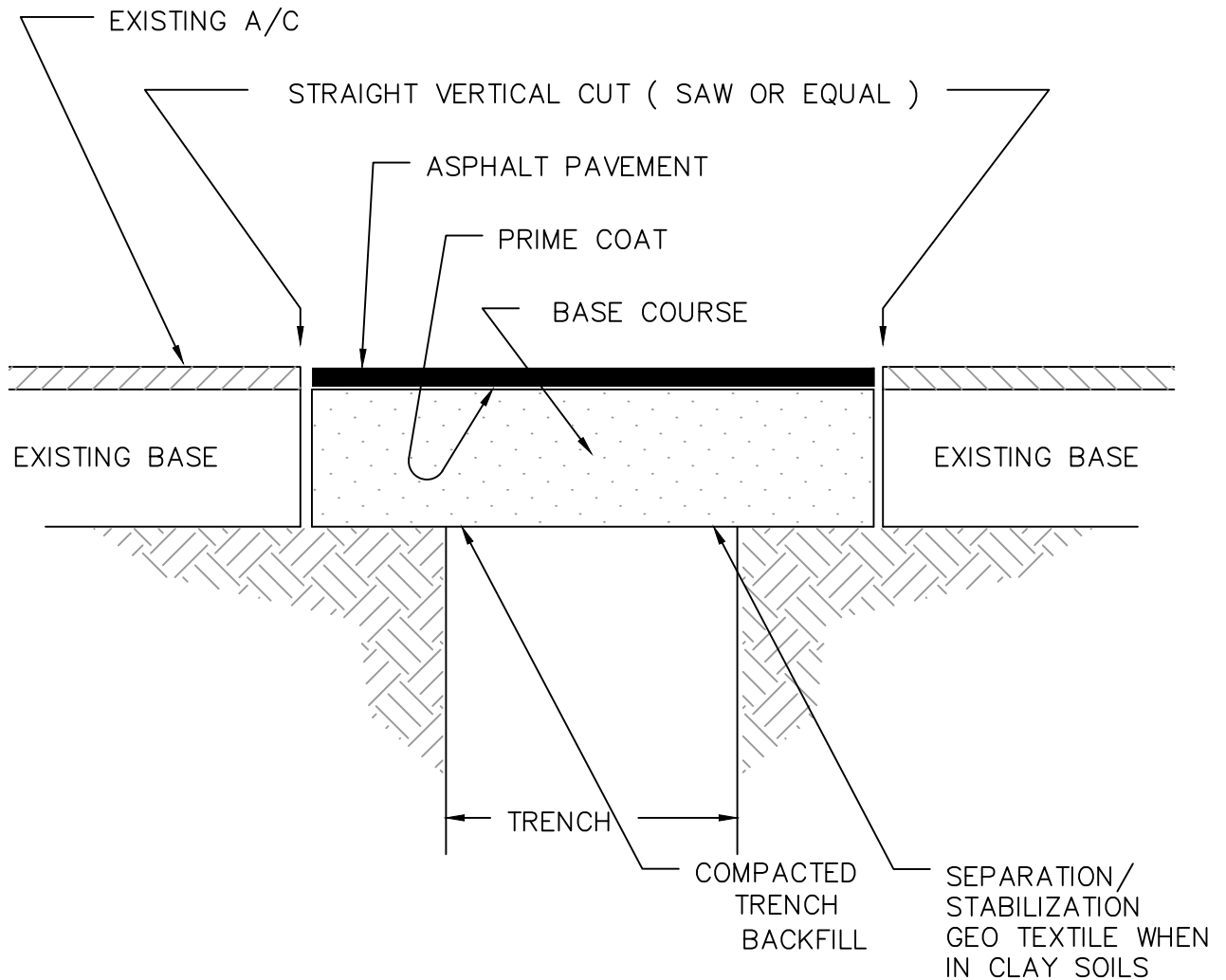

Note ; A note was removed as well

PAVEMENT TO BE 2'-0" WIDER THAN WIDTH OF TRENCH EXCAVATION.

IF WITHIN 3' GUTTER (OR EDGE OF ASPHALT ROAD) REMOVE ASPHALT FROM TRENCH TO GUTTER.

PAVEMENT SHALL BE ASPHALTIC CONCRETE ,UNLESS SPECIFIED OTHERWISE.

ASPHALTIC CONCRETE AND BASE COURSE MATERIALS SHALL BE PLACED AS CALLED FOR IN SPECIFICATIONS.

## TYPICAL TRENCH PAVEMENT REPLACEMENT

NOTE: SEE STANDARDS FOR WHEN TRACER WIRE IS REQUIRED

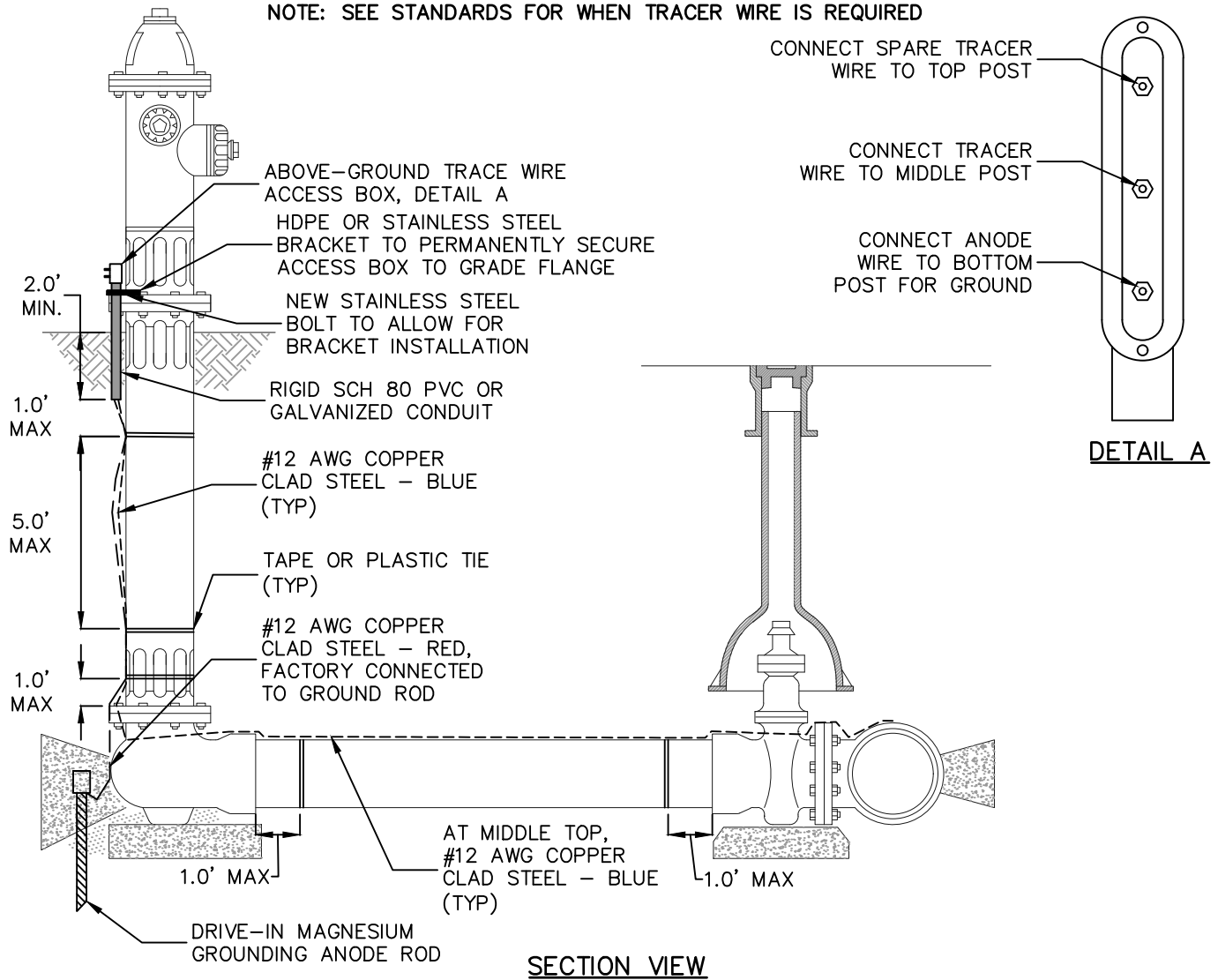

**SECTION VIEW**

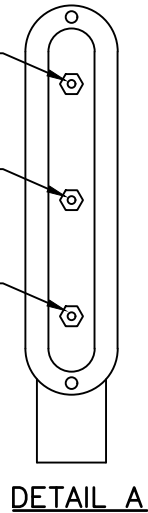

**DETAIL A**

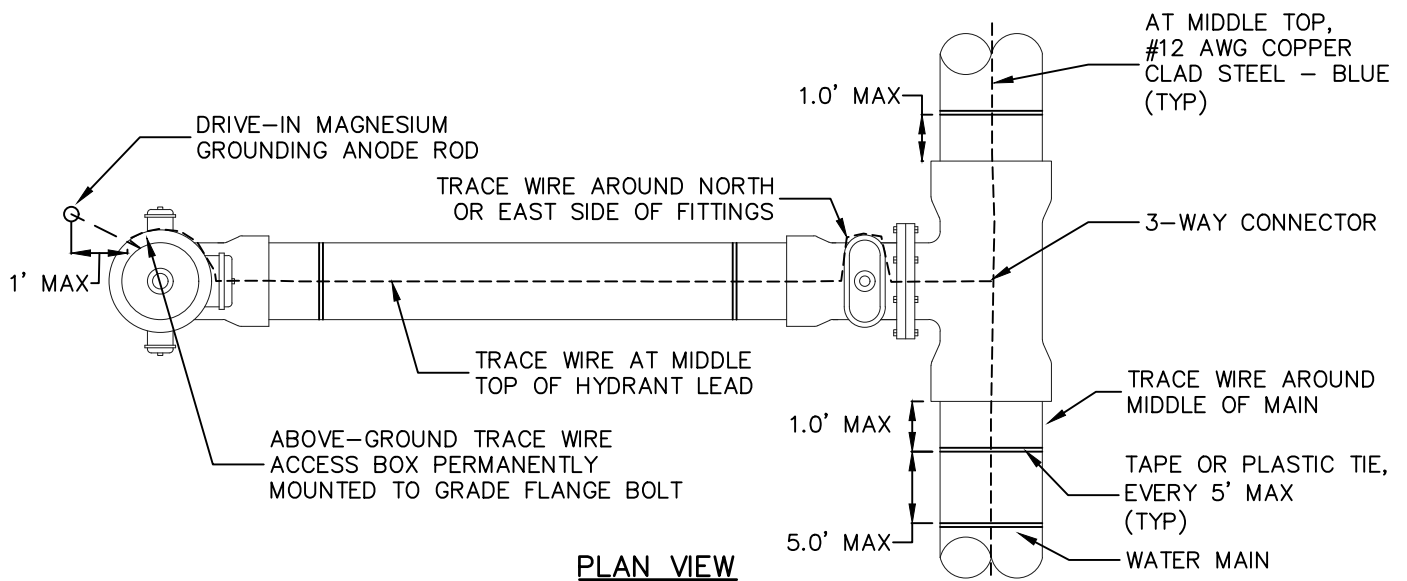

**PLAN VIEW**

**TRACE WIRE - HYDRANT DETAIL**

Notes :

1. The use of "Drop In" risers to achieve final grade is not allowed.
2. Three piece riser shall be used. A four piece riser with upward adjustment shall be allowed for deeper valves.
3. Engineer may require additional support and rebar anchor system for valves 12" and smaller depending on location and project conditions.
4. All bolts, mechanical and flanged joint fittings shall be double wrapped with polyethylene encasement in accordance with AWWA C105, and wrapped with Wax-Tape System.
5. 16" or larger sized valves shall be butterfly valves. Operating nut shall be on south or east side of water main. Epoxy coated rebar anchor system required.

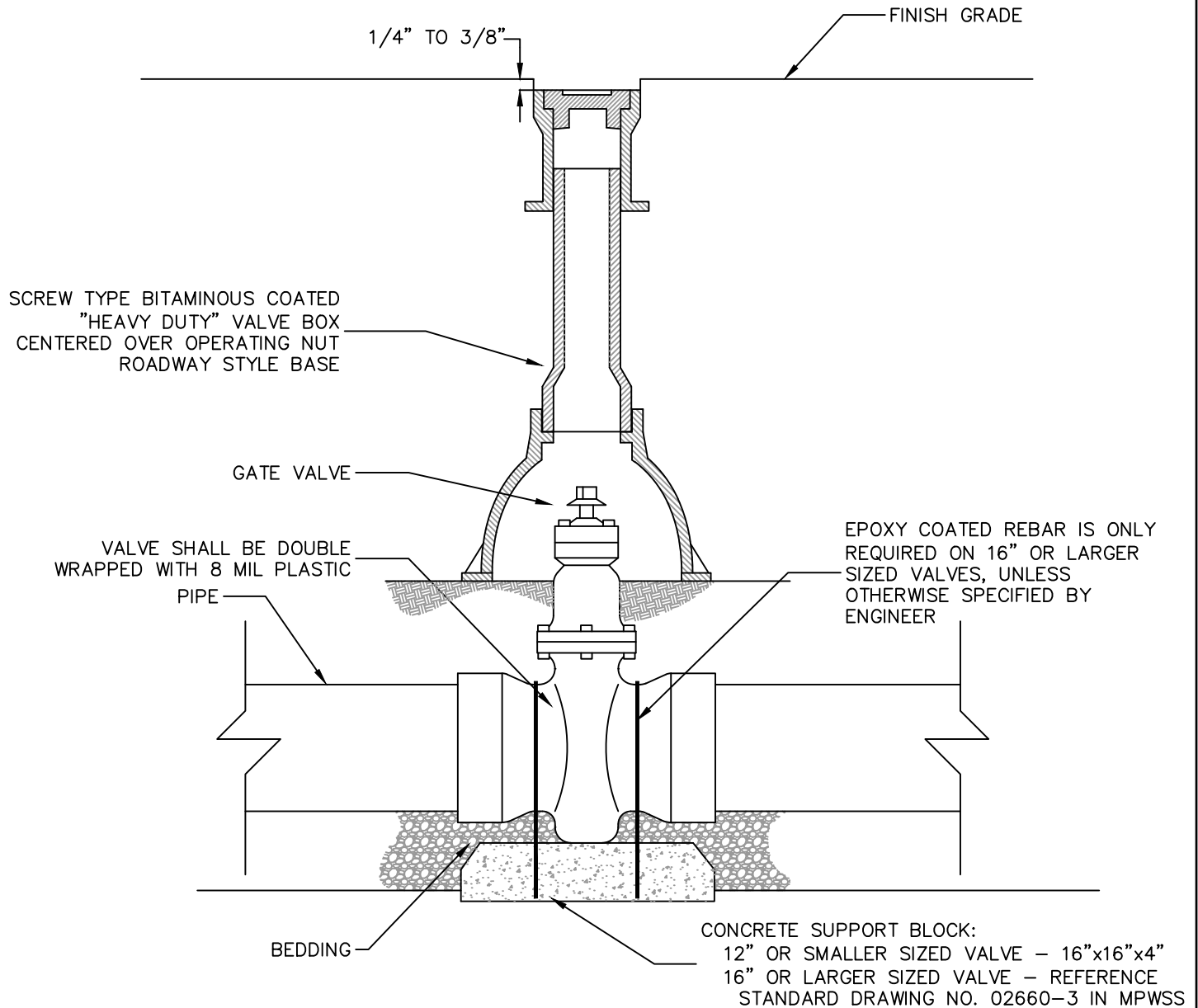

STANDARD GATE VALVE DETAIL

Notes :

1. Tee on main shall be inline push-on X flange with flange to hydrant lead.
2. Hydrant thrust blocking shall have a minimum bearing area of 2 sq. ft. on undisturbed soil.
3. All bolts, mechanical and flanged joint fittings shall be double wrapped with polyethylene encasement in accordance with AWWA C105, and wrapped with Wax-Tape System.
4. Concrete thrust blocks shall meet requirements of Standard Drawing 5-43.

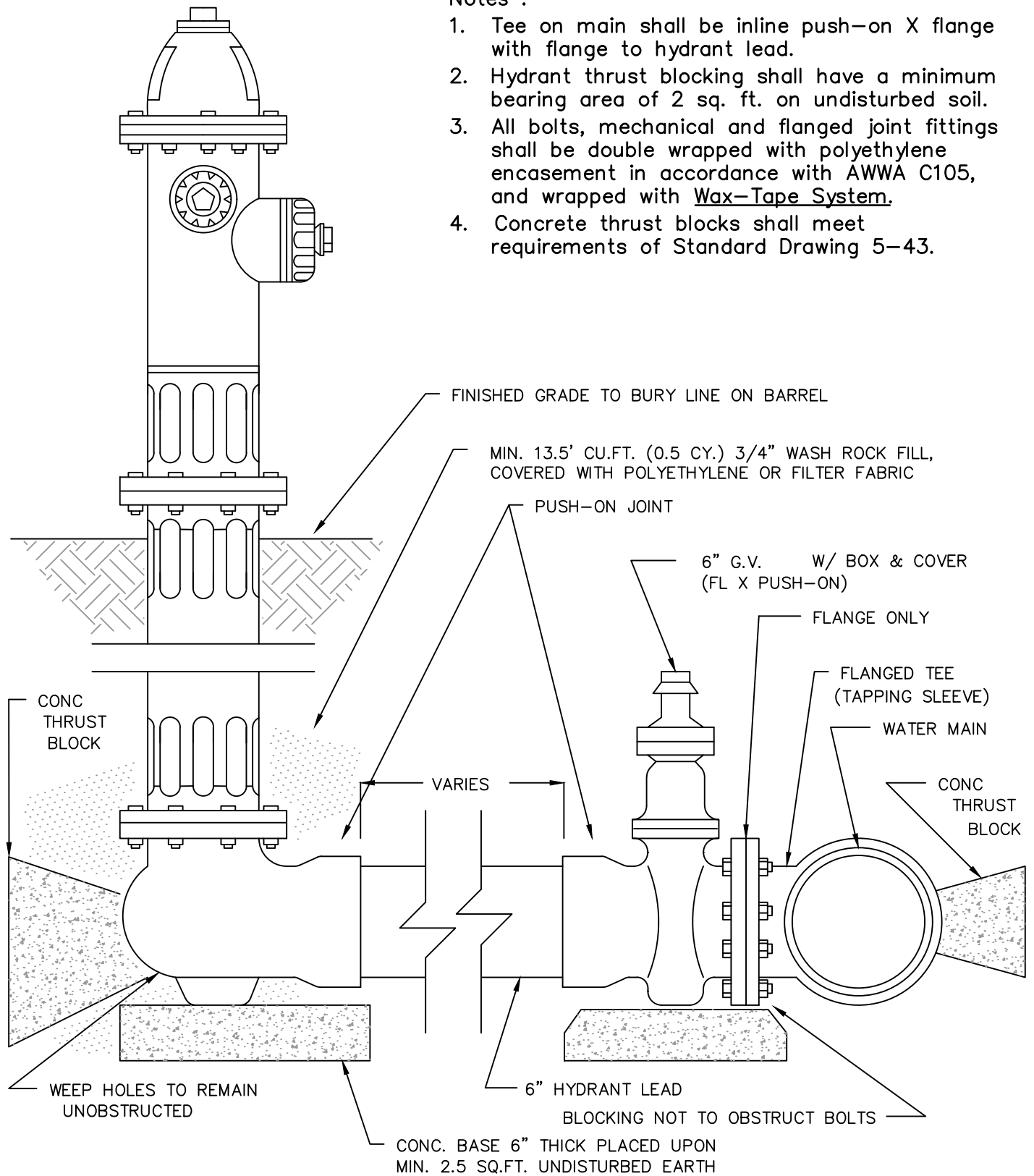

**STANDARD FIRE HYDRANT DETAIL**

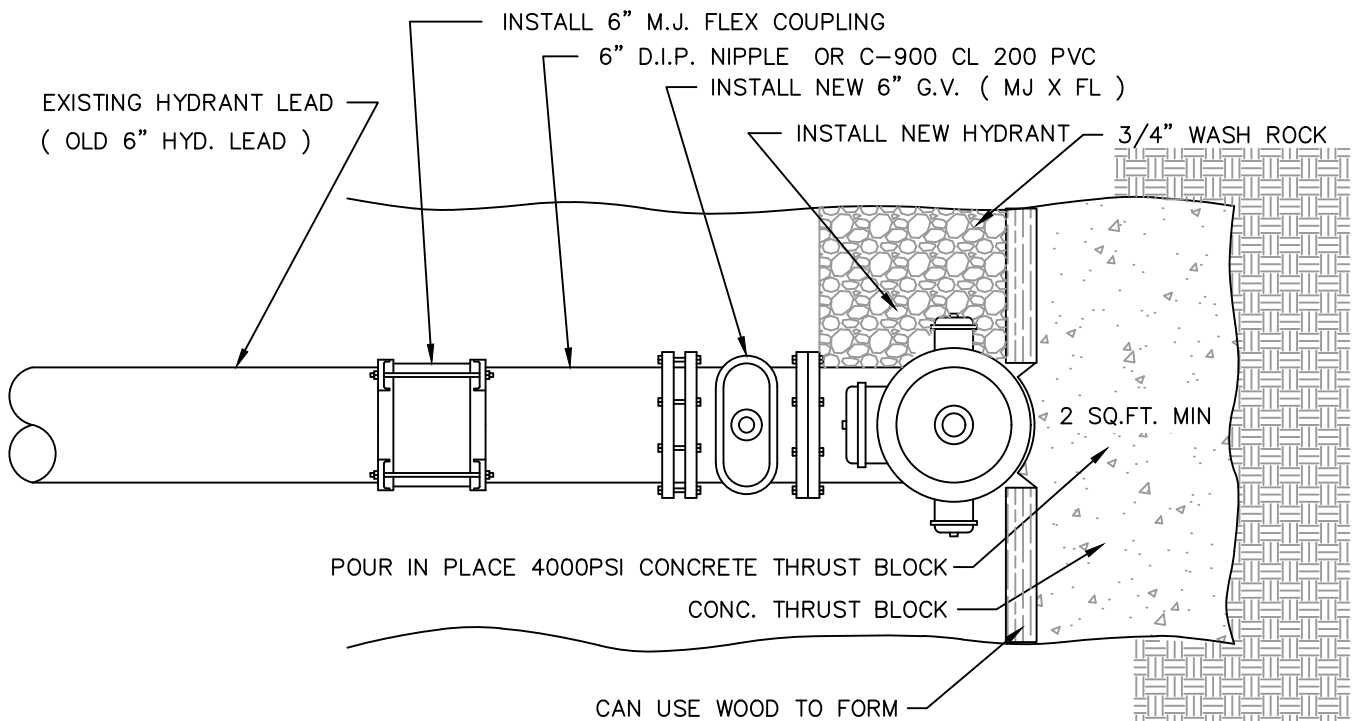
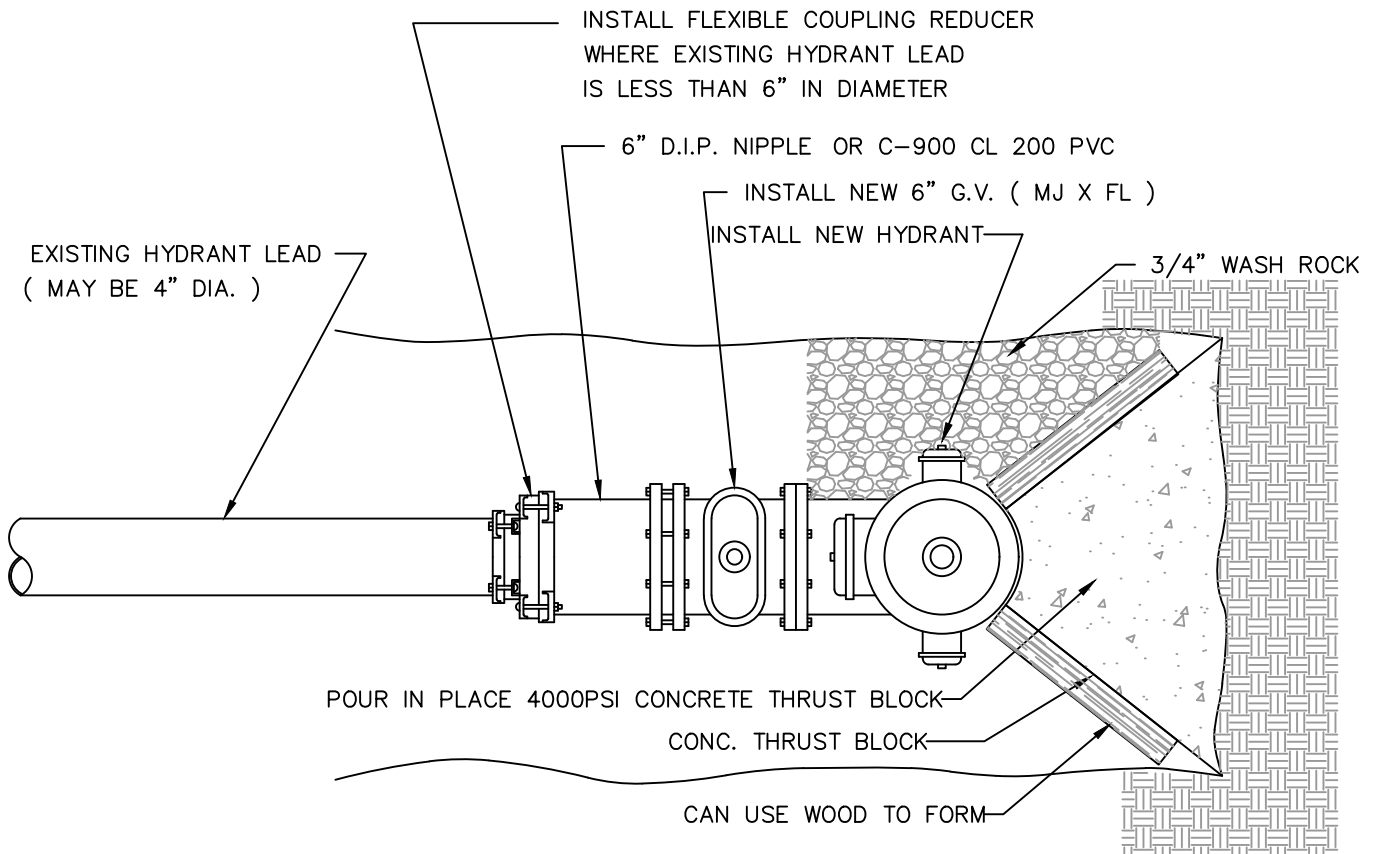

## FIRE HYDRANT REPLACEMENT ON EXISTING HYDRANT LEAD

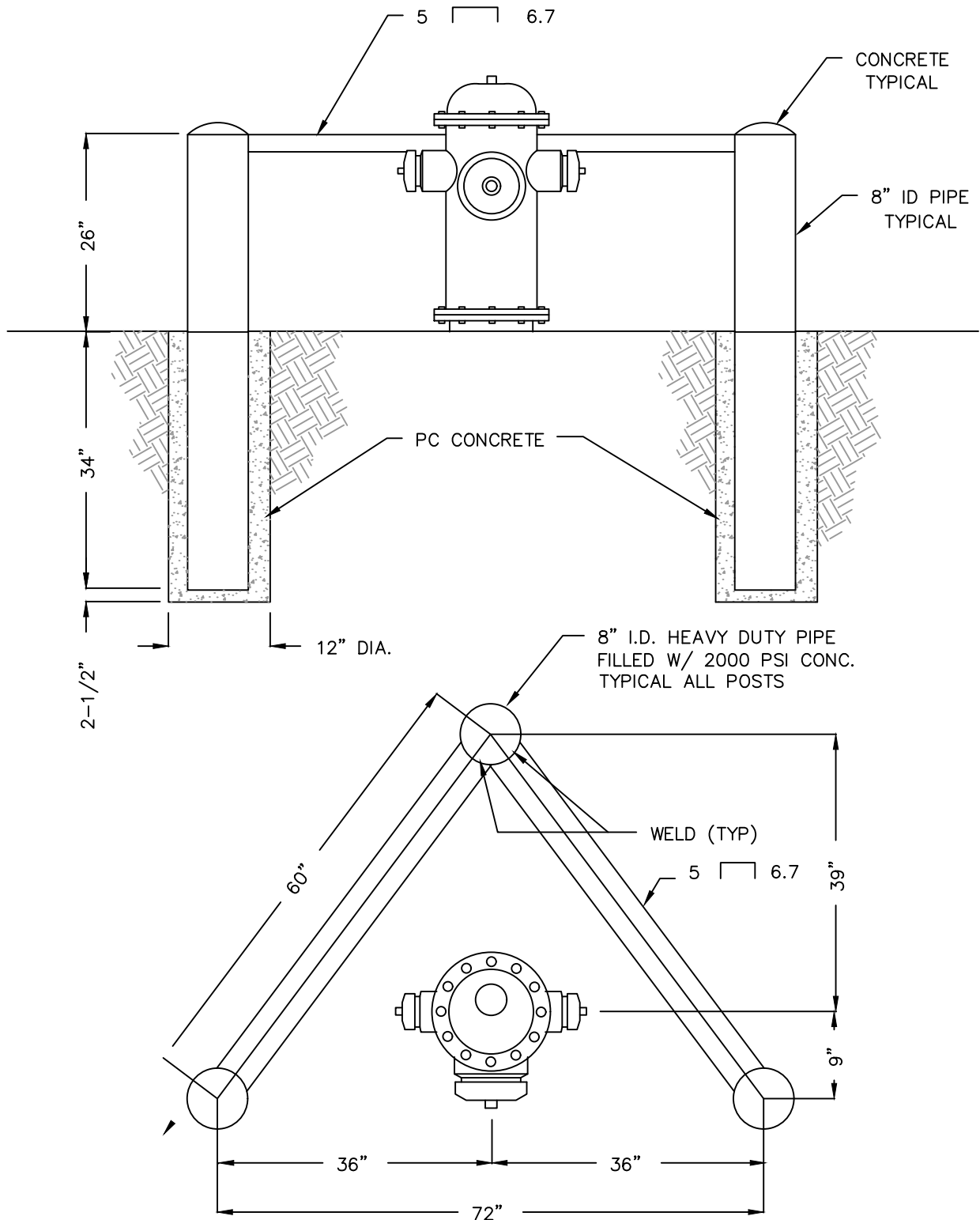

NOTE: PAINT POSTS AND CROSSBAR MUELLER YELLOW

### TYPICAL FIRE HYDRANT GUARD

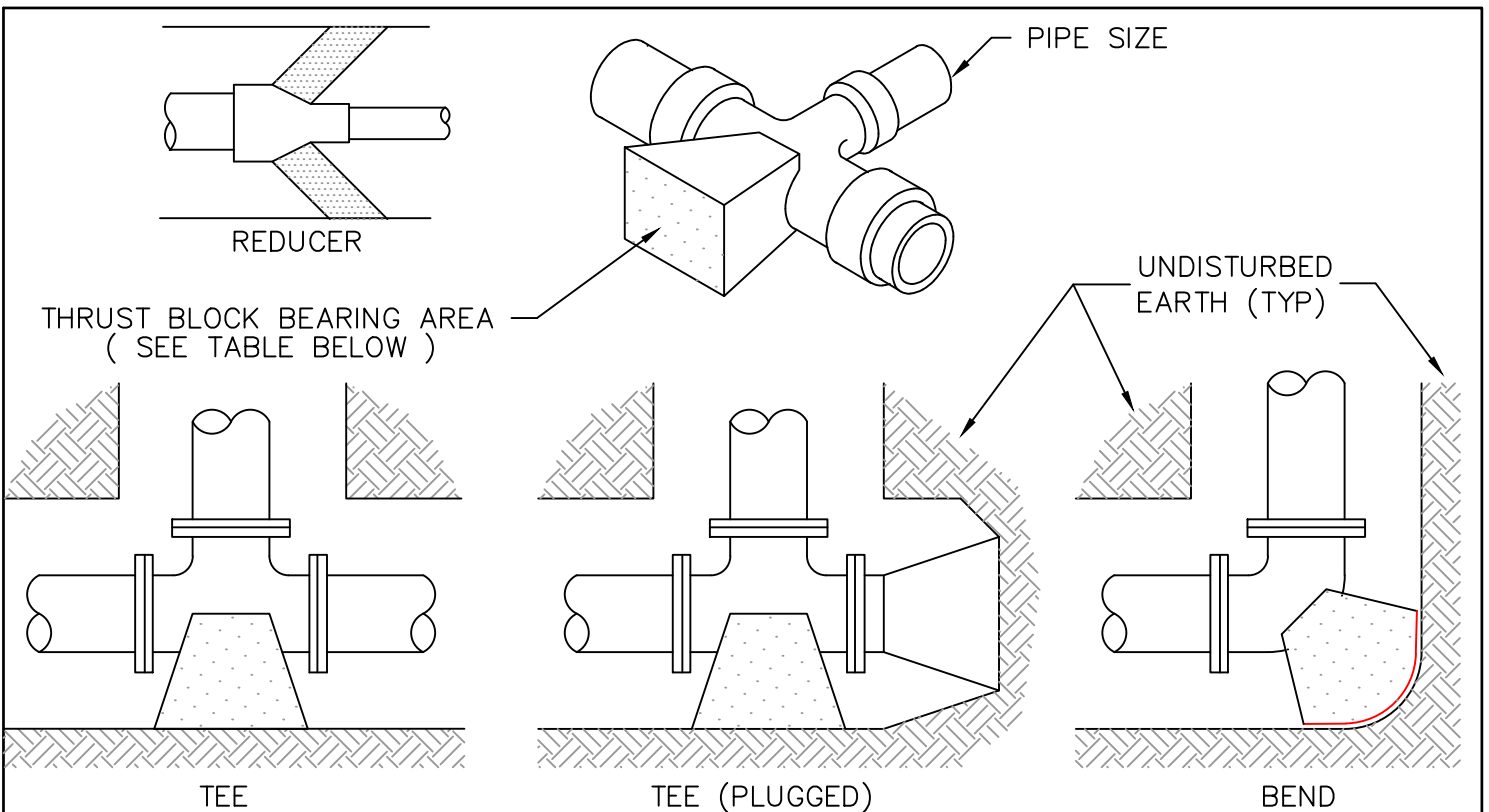

\* Blocking for tapping sleeves shall be the same as tee.

# Blocking is required on reducer (or increaser ) if reducing over one pipe size.

**MINIMUM THRUST BLOCK BEARING AREA ( SQUARE FEET)**

PIPE SIZE	TEES * & PLUGS	90 Deg BEND	45 Deg & WYES	22-1/2 BEND & REDUCER #	VALVES
4"	1.8	2.6	1.4	0.8	4.0
6"	3.8	5.2	2.9	1.5	4.0
8"	6.7	9.5	5.0	2.6	4.0
10"	10.8	15.3	8.3	4.2	6.25
12"	15.3	21.8	11.9	5.8	9.0
14"	20.8	28.8	16.2	8.3	10.5
16"	27.4	37.7	20.9	10.8	16.0
18"	34.7	47.7	26.6	13.6	16.25
20"	42.8	58.9	32.7	16.8	
24"	61.7	84.8	47.1	24.2	32.5
30"	96.4	123.5	73.6	37.9	

- NOTE:
1. This table is based on 150# PSI main pressure & 2000 # soil pressure.
  2. Wrap all fittings with polyethylene.
  3. Blocking for valves per Standard Detail No. 5-39.
  4. Concrete used for thrust blocks shall be allowed to 'CURE' for approx. 24 hours.

**THRUST BLOCKING DETAILS FOR WATER MAIN FITTINGS**



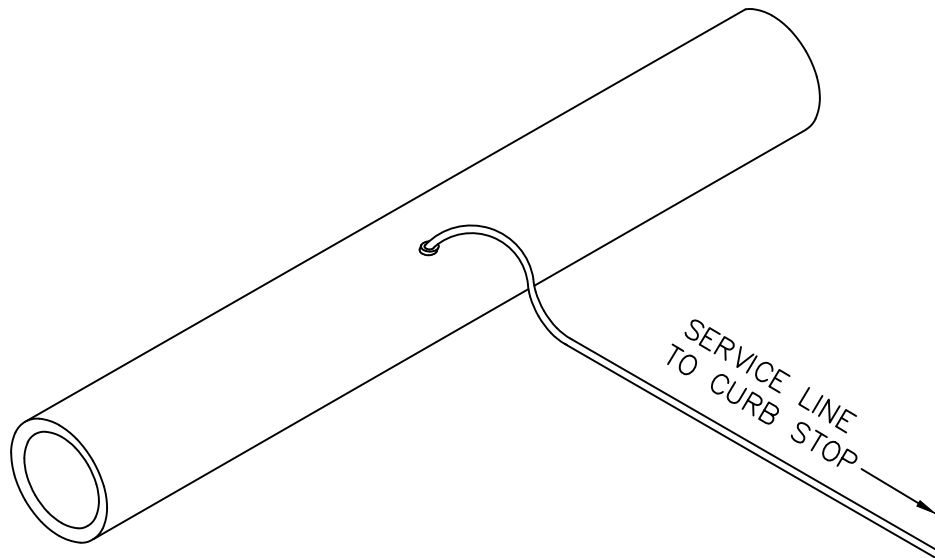
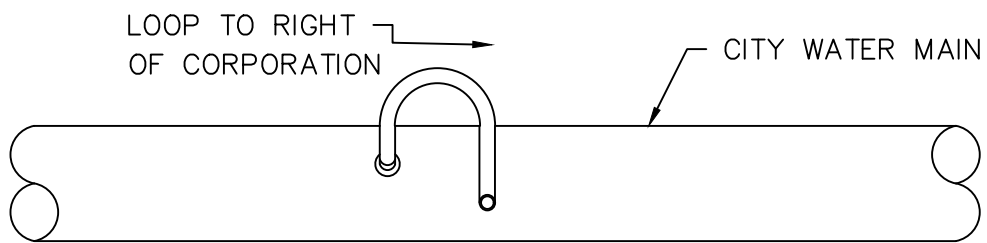
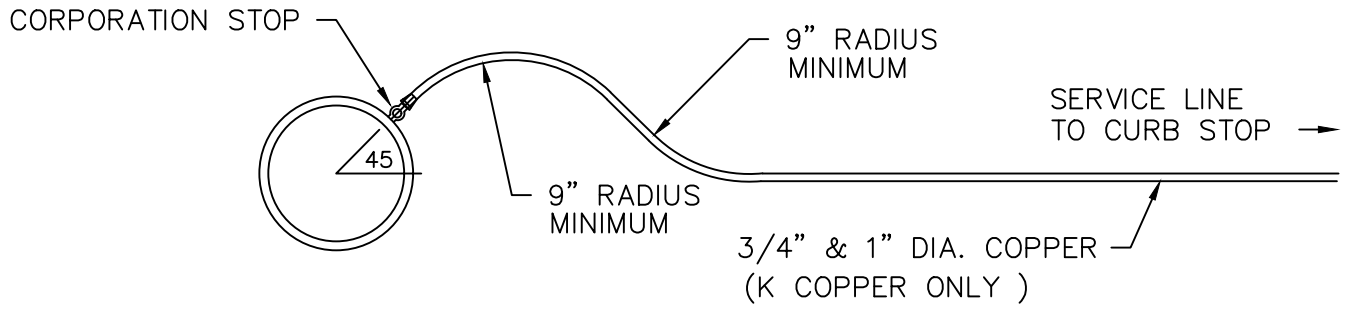

NOTE : CORPORATION STOP PROVIDED & INSTALLED BY CITY.

TAP MAY REQUIRE SADDLE ON ACP OR PVC MAINS.

**EXPANSION LOOP – WATER SERVICE LINE CONNECTION AT MAIN**

Note : Removed "BID UNIT" from the callouts indicated.

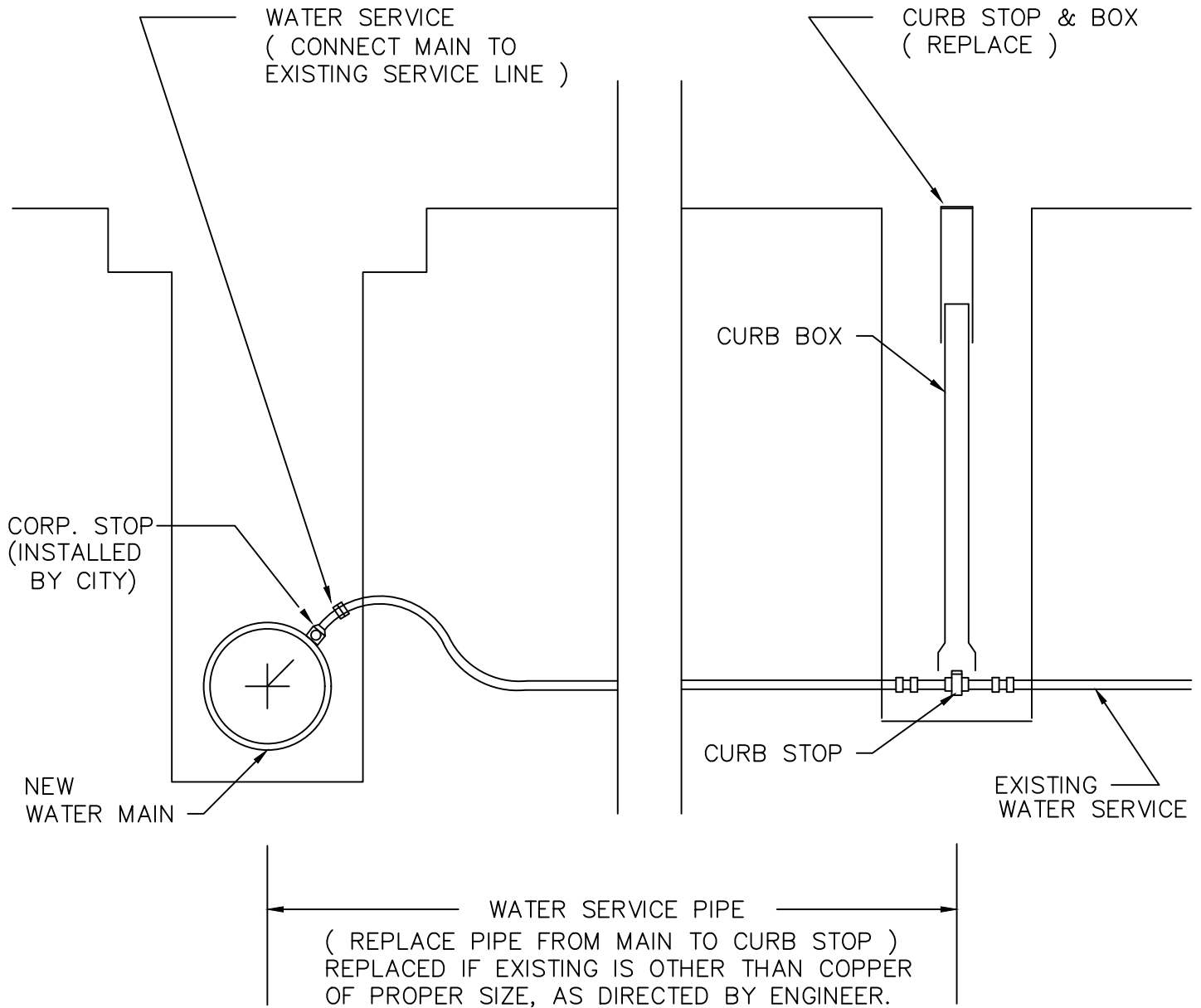

NOTE : CORP. STOP & SADDLE PROVIDED BY CONTRACTOR & INSTALLED BY CITY  
CURB STOP & CURB BOX PROVIDED BY AND INSTALLED BY CONTRACTOR  
TAPPING SADDLE MAY BE REQUIRED IF MAIN OTHER THAN D.I.P.  
SAND BEDDING REQUIRED FOR COPPER SERVICE LINE

## WATER MAIN REPLACEMENT – WATER SERVICE CONNECTIONS

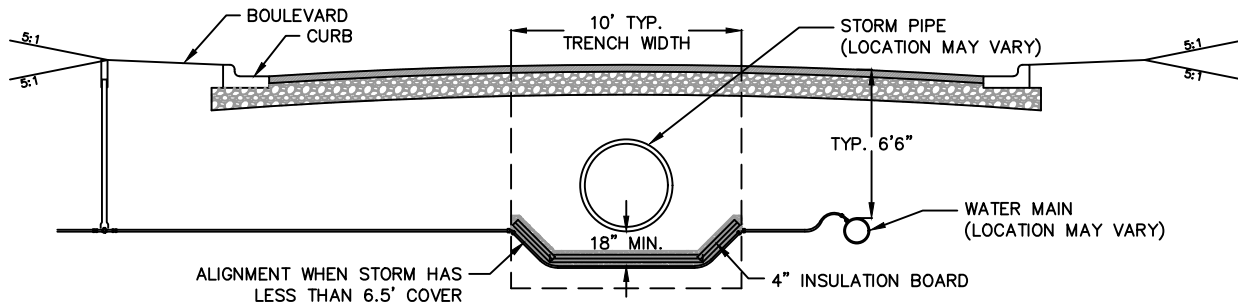

CROSS SECTION

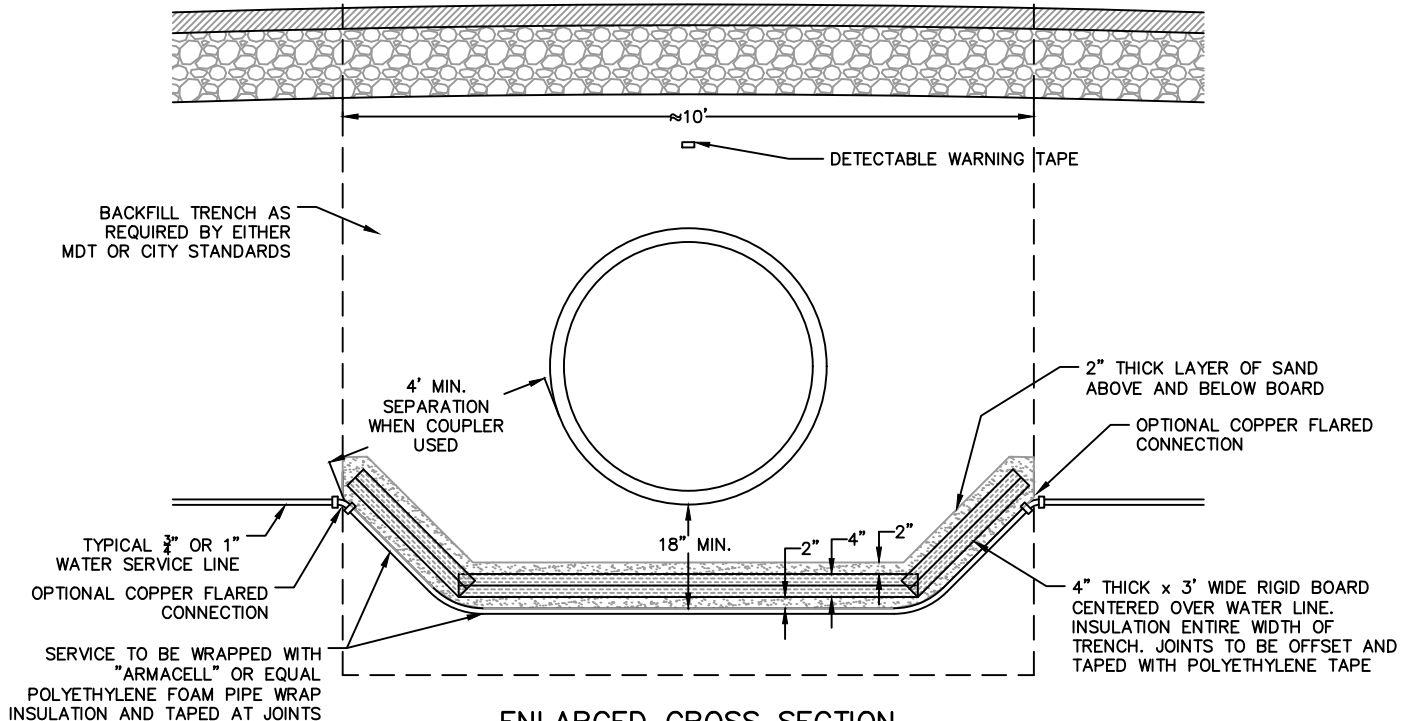

ENLARGED CROSS SECTION

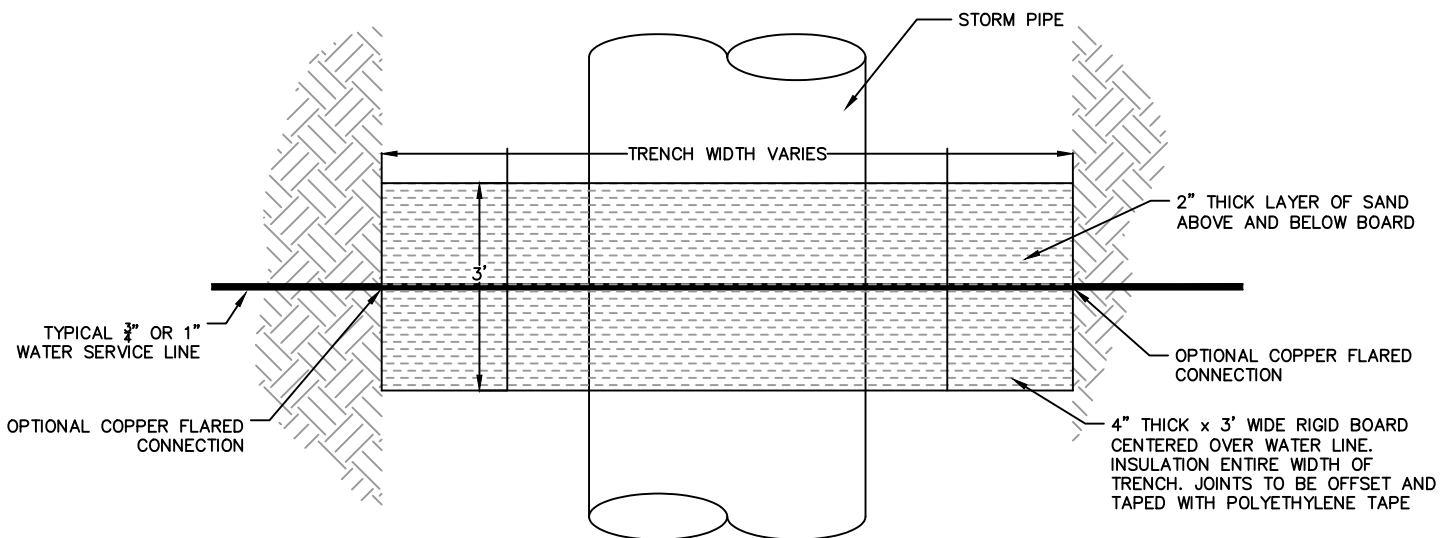

PLAN DETAIL

WATER SERVICE CROSSING BELOW STORM

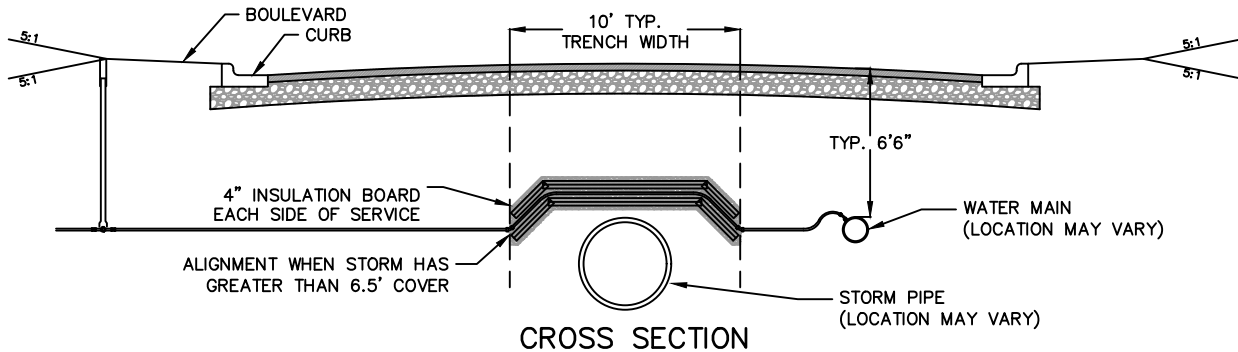

CROSS SECTION

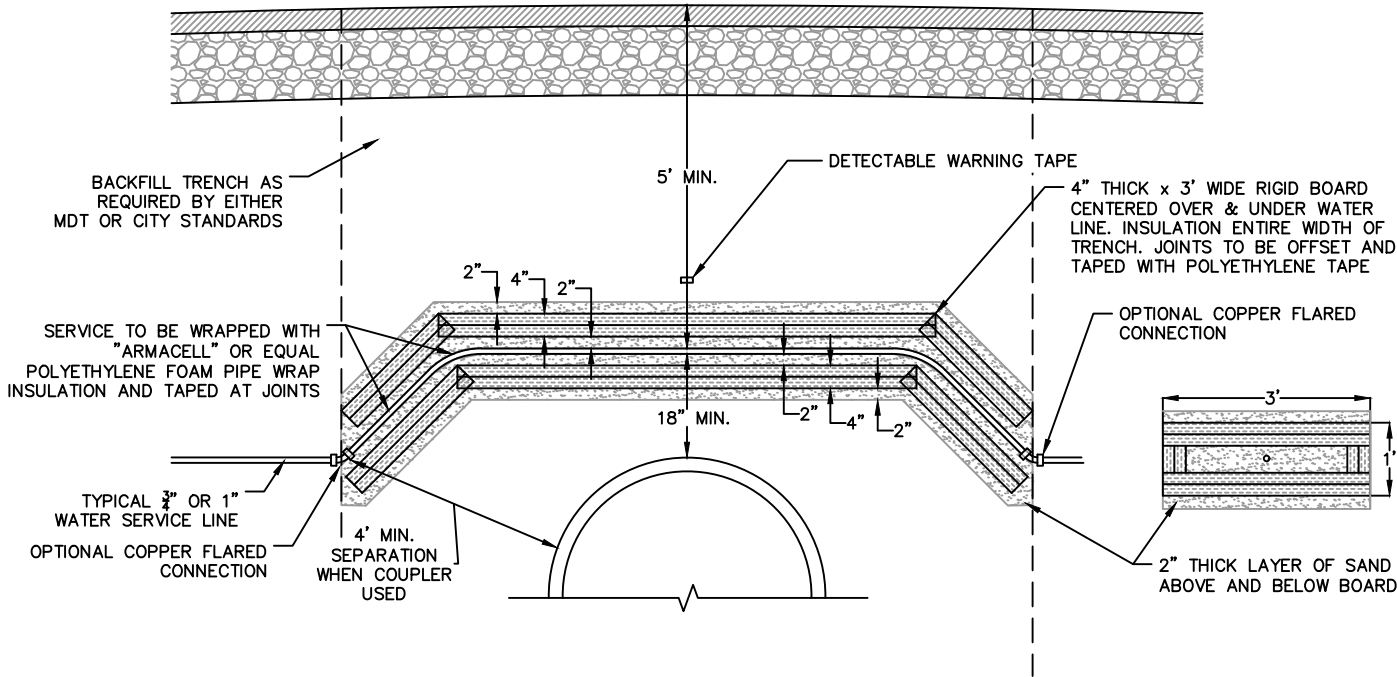

ENLARGED CROSS SECTION

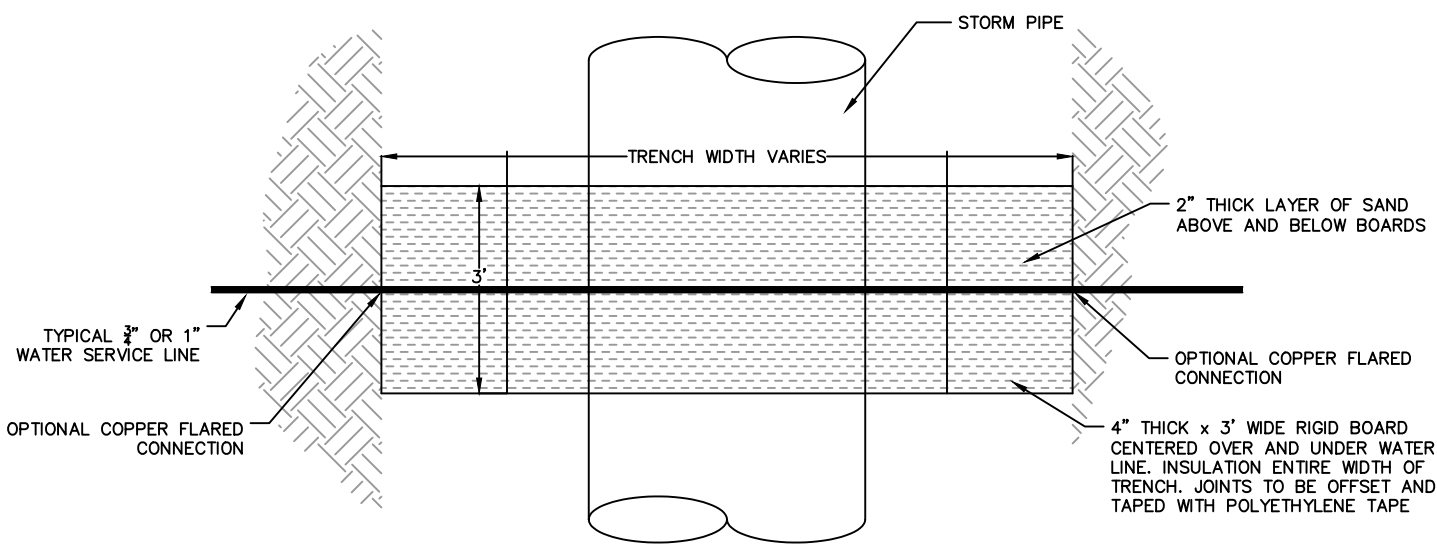

PLAN DETAIL

WATER SERVICE CROSSING ABOVE STORM

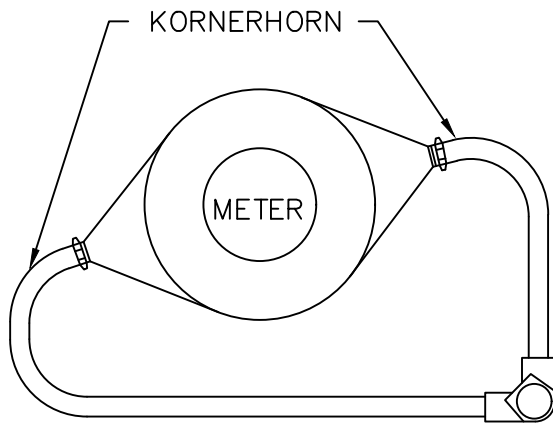
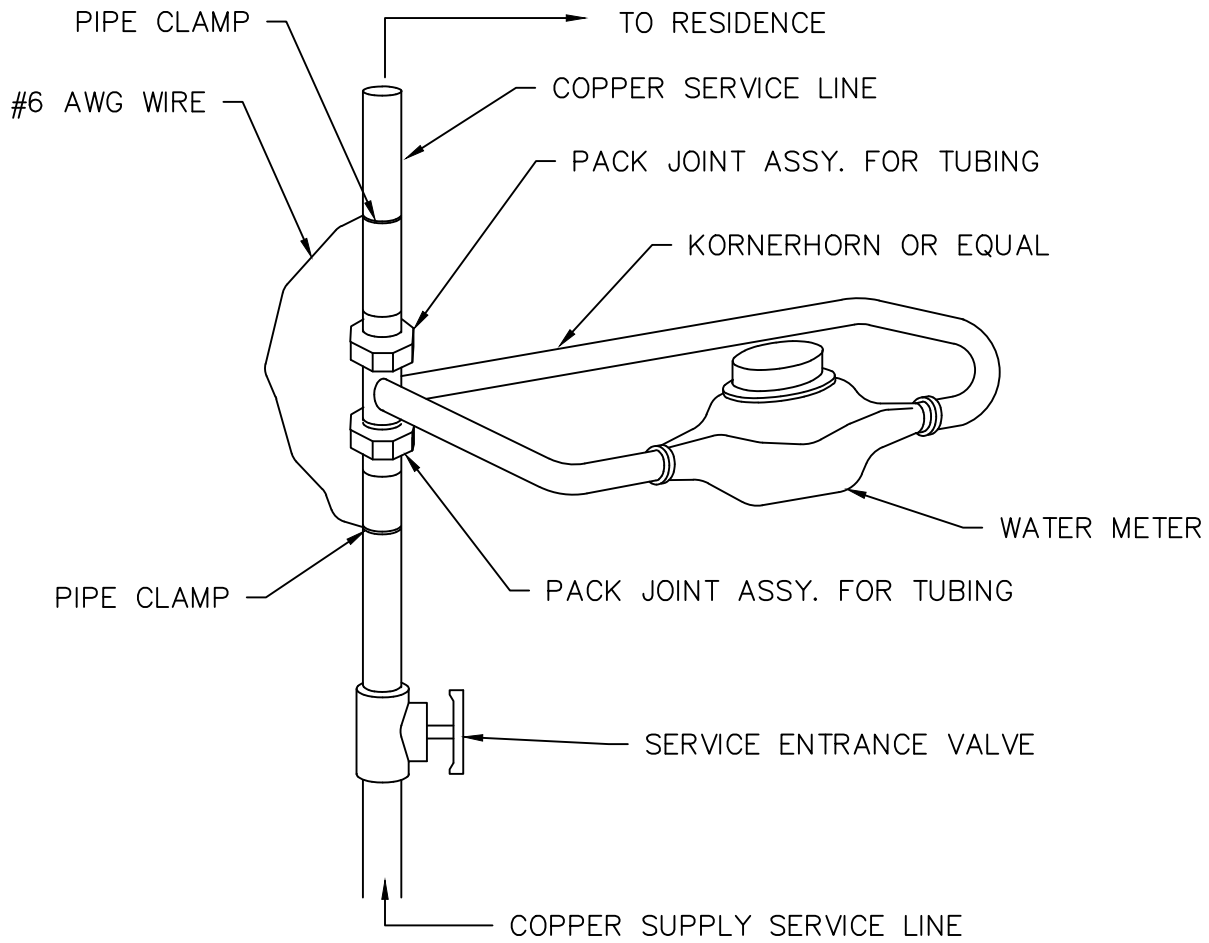

PLAN (TOP VIEW)

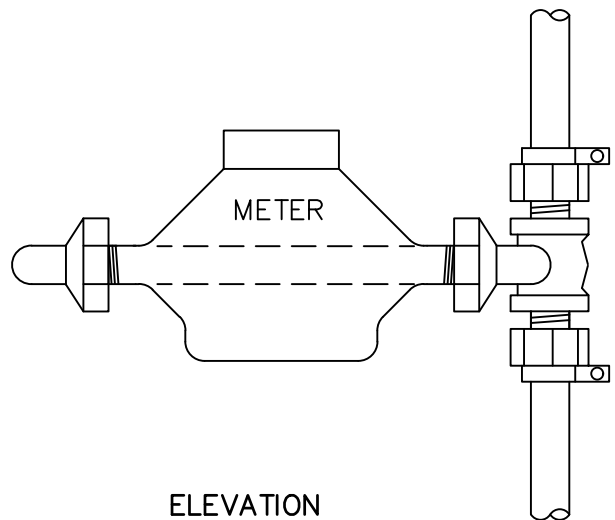

ELEVATION

TYPICAL WATER METER INSTALLATION

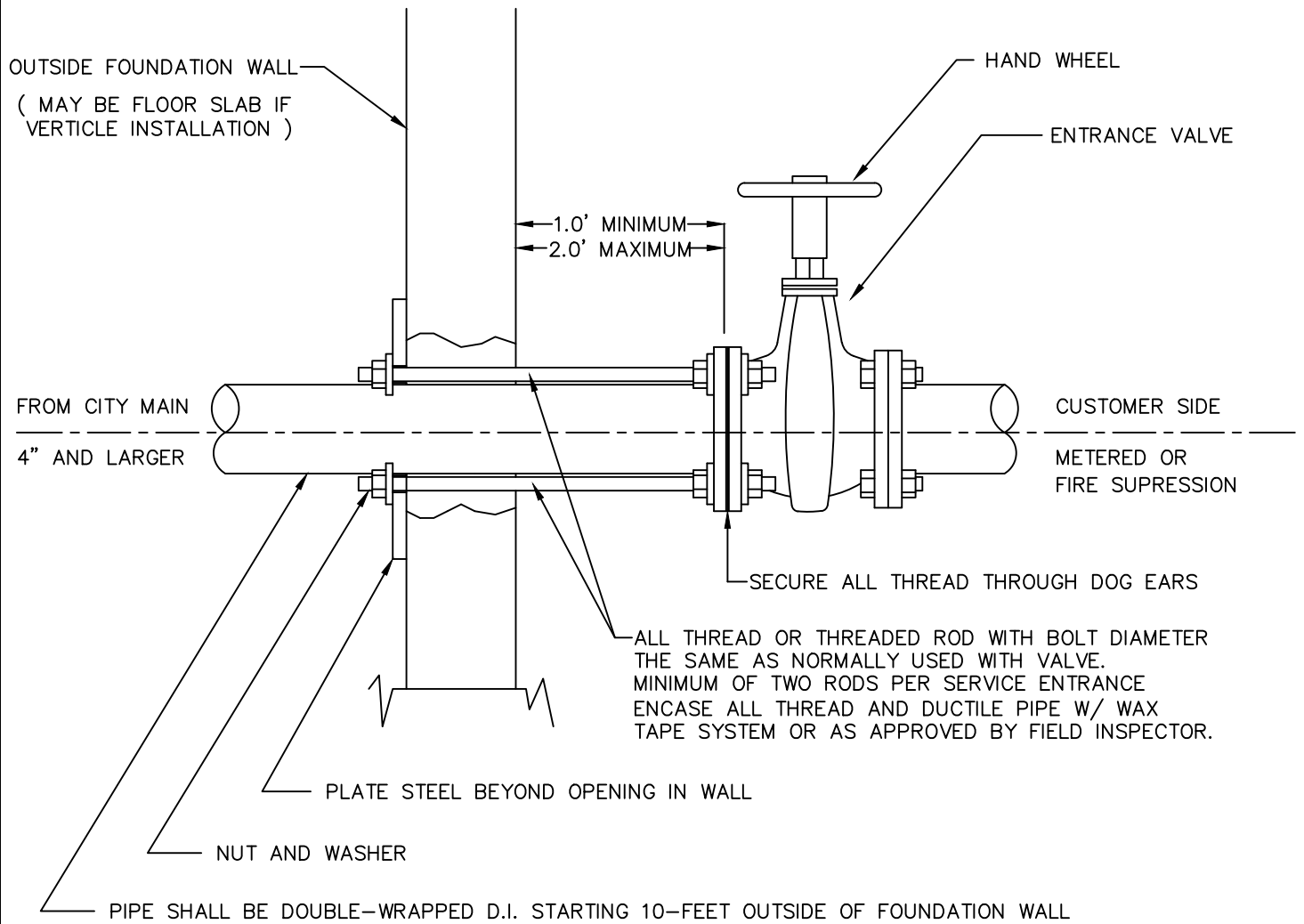

WATER PROOF COATING ON ALL METAL OUTSIDE FOUNDATION WALL

## WATER SERVICE ENTRANCE 4" AND LARGER DIAMETER

NOTE :

CURB BOX SHALL BE LOCATED IMMEDIATELY BEHIND CURB OR SIDEWALK  
 METER PIT SHALL BE PLACED ADJACENT TO DISCHARGE SIDE OF CURB BOX.

METER PIT DEPTH IS APPROXIMATELY 7' WITH LID. MAKE DEPTH ADJUSTMENTS ON  
 SERVICE LINES OUTSIDE PIT BY RAISING OR LOWERING SERVICE LINE.

DO NOT CUT METER PIT TO MATCH DEPTH OF SERVICE LINE.

NOTE: CHANGED TEXT SIZES TO MATCH EACH OTHER

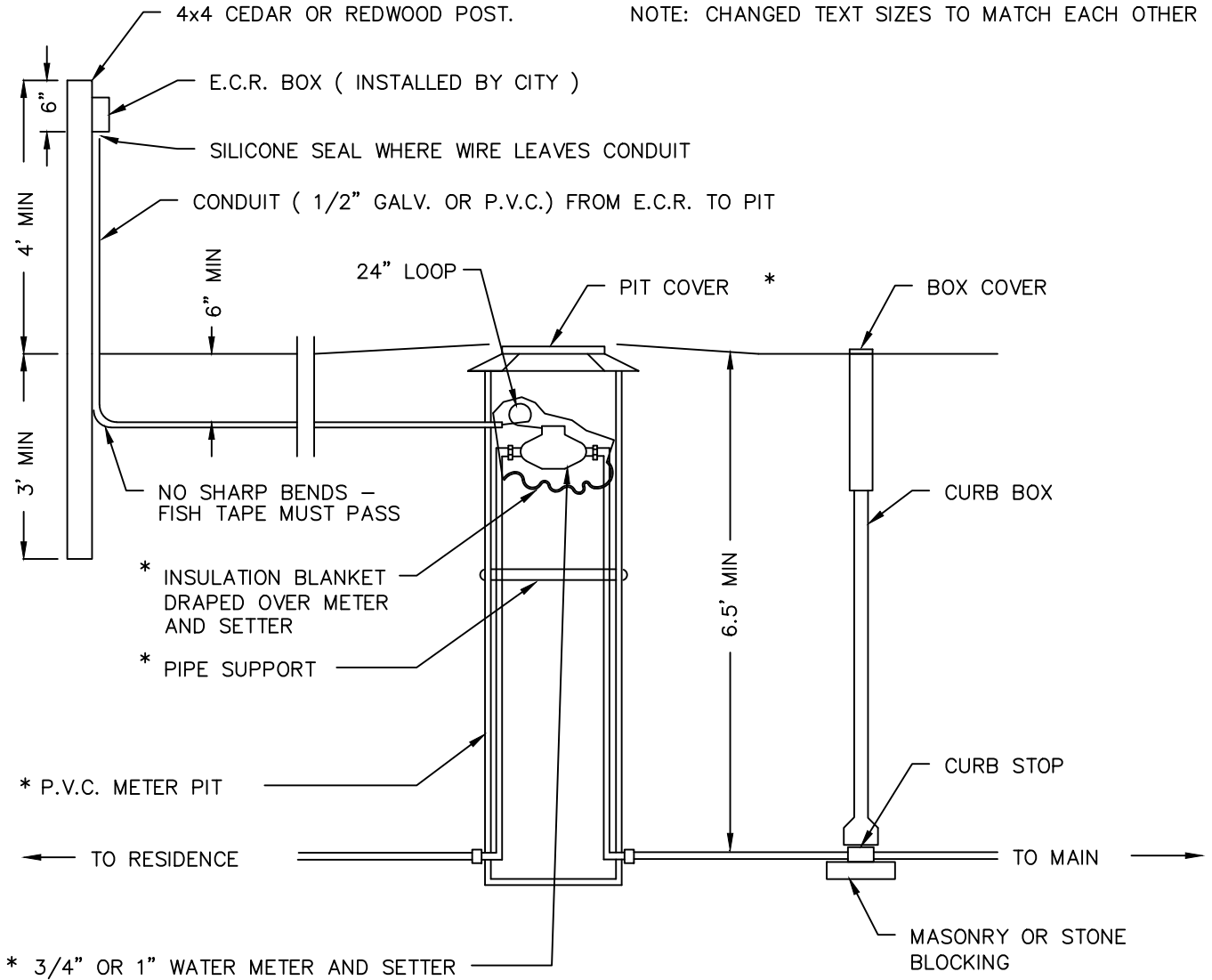

\* = PARTS SUPPLIED BY CITY TO CONTRACTOR ON EXIST. USED SERVICE LINES

NOTE:

PLUMBER SHALL SEAL METER REGISTER WITH DOW-CORNING SILICONE SEALANT  
 OR APPROVED EQUAL.

RESIDENTIAL WATER METER PIT

**NOTES :**

1. THE SIZE OF BYPASS LINE TO BE DETERMINED BY FIRE FLOW REQUIREMENTS, HOWEVER, IN NO CASE SHALL A BYPASS LINE BE MORE THAN ONE (1) PIPE SIZE SMALLER THAN THE PRIMARY FEED. ALL FITTINGS ON 4" AND LARGER PIPE SHALL BE FLANGED, LESS THAN 4" MAY BE THREADED.
2. A CHECK VALVE SHALL BE INSTALLED ON DISCHARGE SIDE OF VALVING IF ON A LOOPED SYSTEM OR WHERE HIGHER HEADS MAY BE DEVELOPED ON DISCHARGE SIDE.
3. VAULT SHALL NOT BE PLACED IN AN AREA ACCESSIBLE TO VEHICLE TRAFFIC. ACCESS HATCH TO BE CENTERED OVER WATER METER AND SIZED TO ALLOW REMOVAL OF METER, MINIMUM SIZE OF HATCH MUST ALLOW PERSONNEL TO ENTER AND EXIT VAULT. HATCH SHALL BE APPROVED BY CITY PRIOR TO INSTALLATION.
4. RIGID INSULATION SHALL BE APPLIED TO OUTSIDE OF VAULT TO A DEPTH OF 3' BELOW GROUND SURFACE. MANHOLE FRAME AND COVER SHALL BE INSULATED WITH ADHESIVE TYPE FOAM INSULATION.
5. IF VAULT IS NEAR GROUND WATER, WATER PROOFING SHALL BE APPLIED TO THE OUTSIDE OF VAULT, NO DRAIN HOLE.
6. REMOTES FOR REMOTE READ METERS SHALL BE MOUNTED ON A 4X4 POST 42" ABOVE GROUND. WIRE SHALL BE RAN INSIDE CONDUIT FROM VAULT TO THE 4X4 POST.

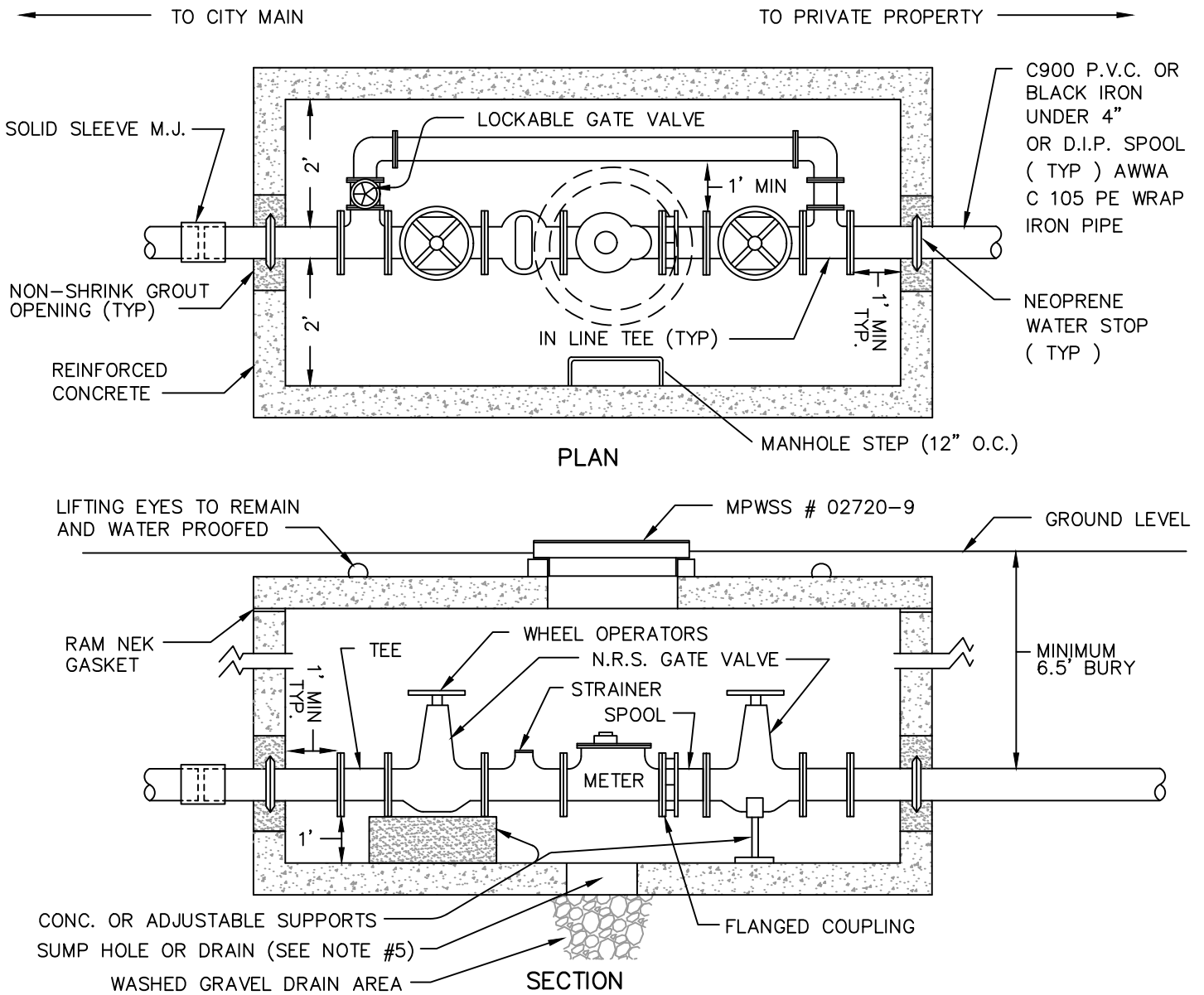

**TYPICAL WATER METER VAULT DETAIL**



**NOTES :**

1. BACKFLOW PREVENTER TYPE AND LOCATION TO BE APPROVED BY CITY PLUMBING INSPECTOR.

**PLAN VIEW**

NO SCALE

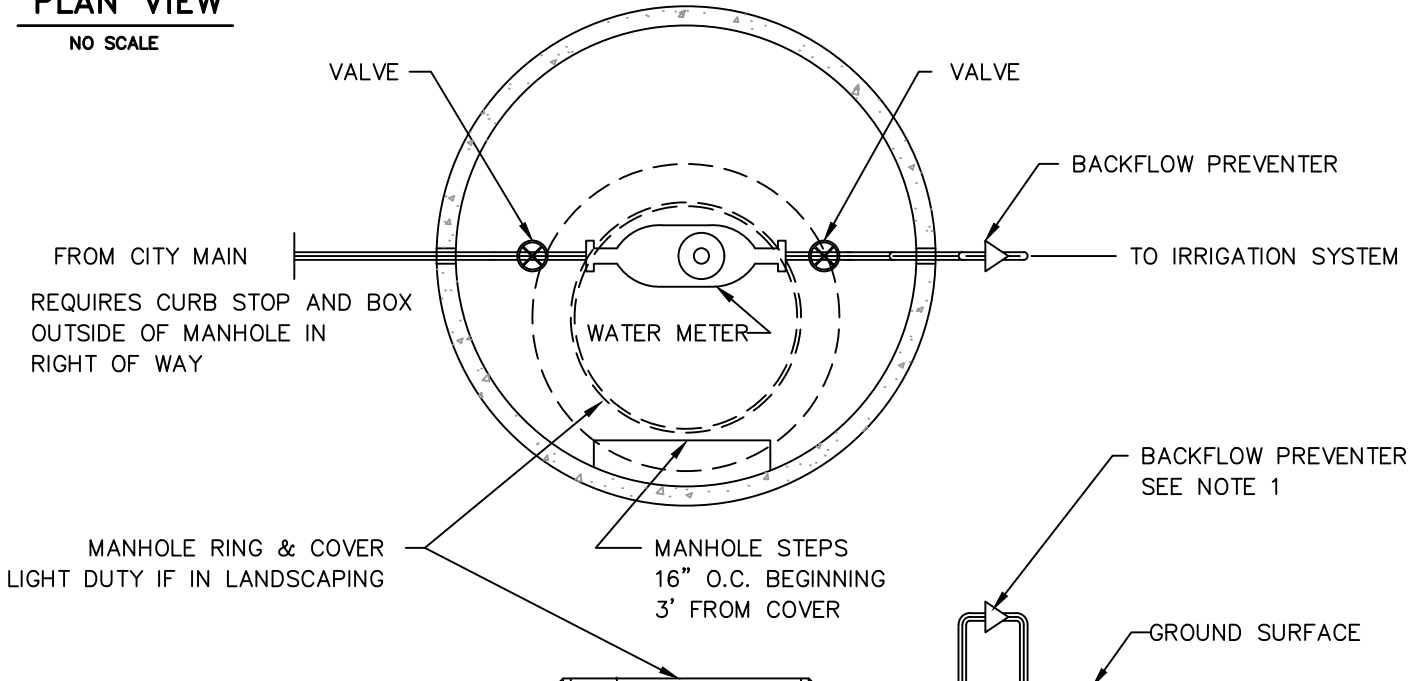

**SECTION VIEW**

NO SCALE

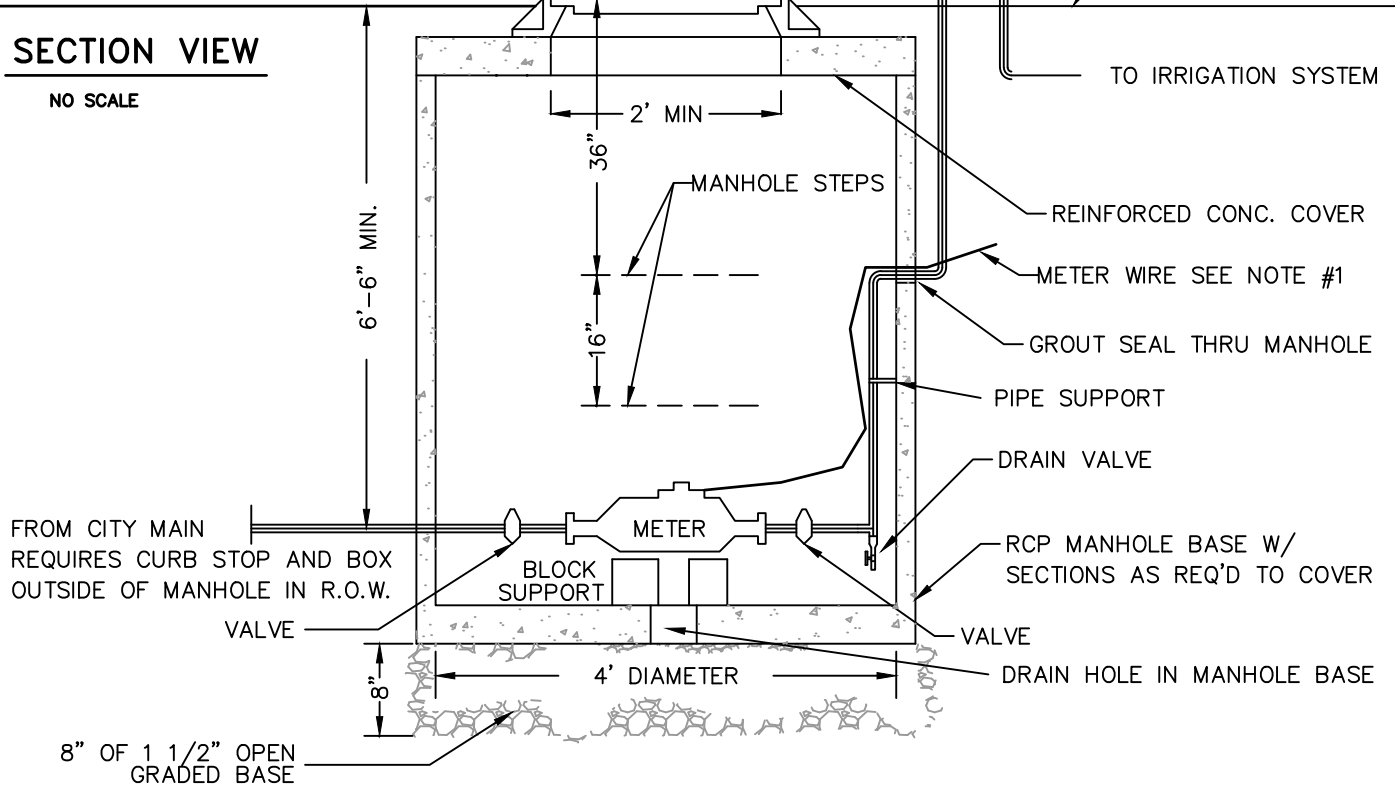

**IRRIGATION MANHOLE FOR 1-1/2" OR LARGER WATER METER**

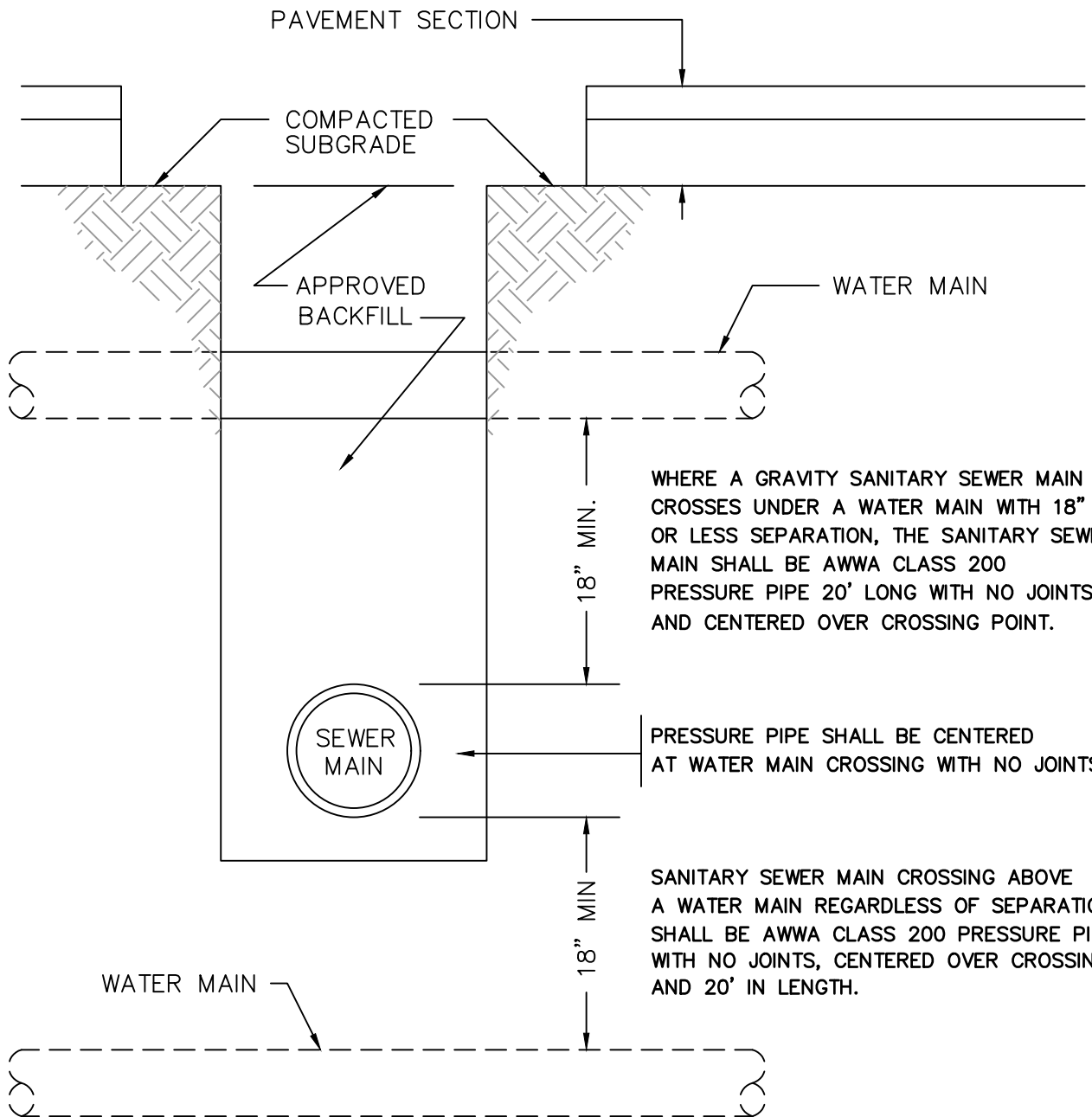

WHERE A GRAVITY SANITARY SEWER MAIN  
CROSSES UNDER A WATER MAIN WITH 18"  
OR LESS SEPARATION, THE SANITARY SEWER  
MAIN SHALL BE AWWA CLASS 200  
PRESSURE PIPE 20' LONG WITH NO JOINTS  
AND CENTERED OVER CROSSING POINT.

PRESSURE PIPE SHALL BE CENTERED  
AT WATER MAIN CROSSING WITH NO JOINTS

SANITARY SEWER MAIN CROSSING ABOVE  
A WATER MAIN REGARDLESS OF SEPARATION  
SHALL BE AWWA CLASS 200 PRESSURE PIPE  
WITH NO JOINTS, CENTERED OVER CROSSING  
AND 20' IN LENGTH.

## SANITARY SEWER MAINS AT WATER MAIN CROSSINGS

NOTES :

- 1) INSTALL ENCLOSURE AND CONCRETE PAD PER MANUFACTURES INSTALLATION DETAILS

**SECTION VIEW**

NO SCALE

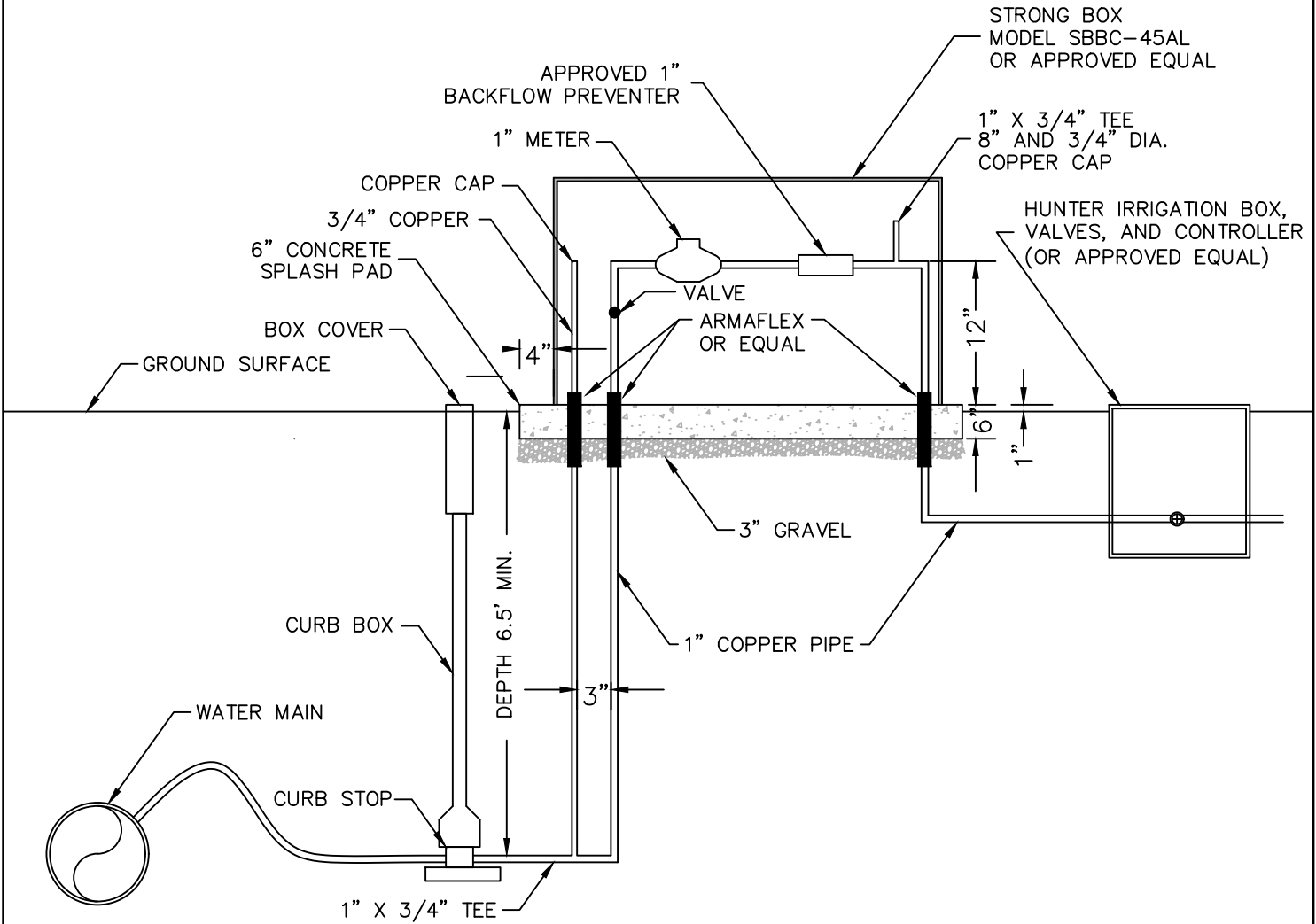

**IRRIGATION DETAIL DRAWING**

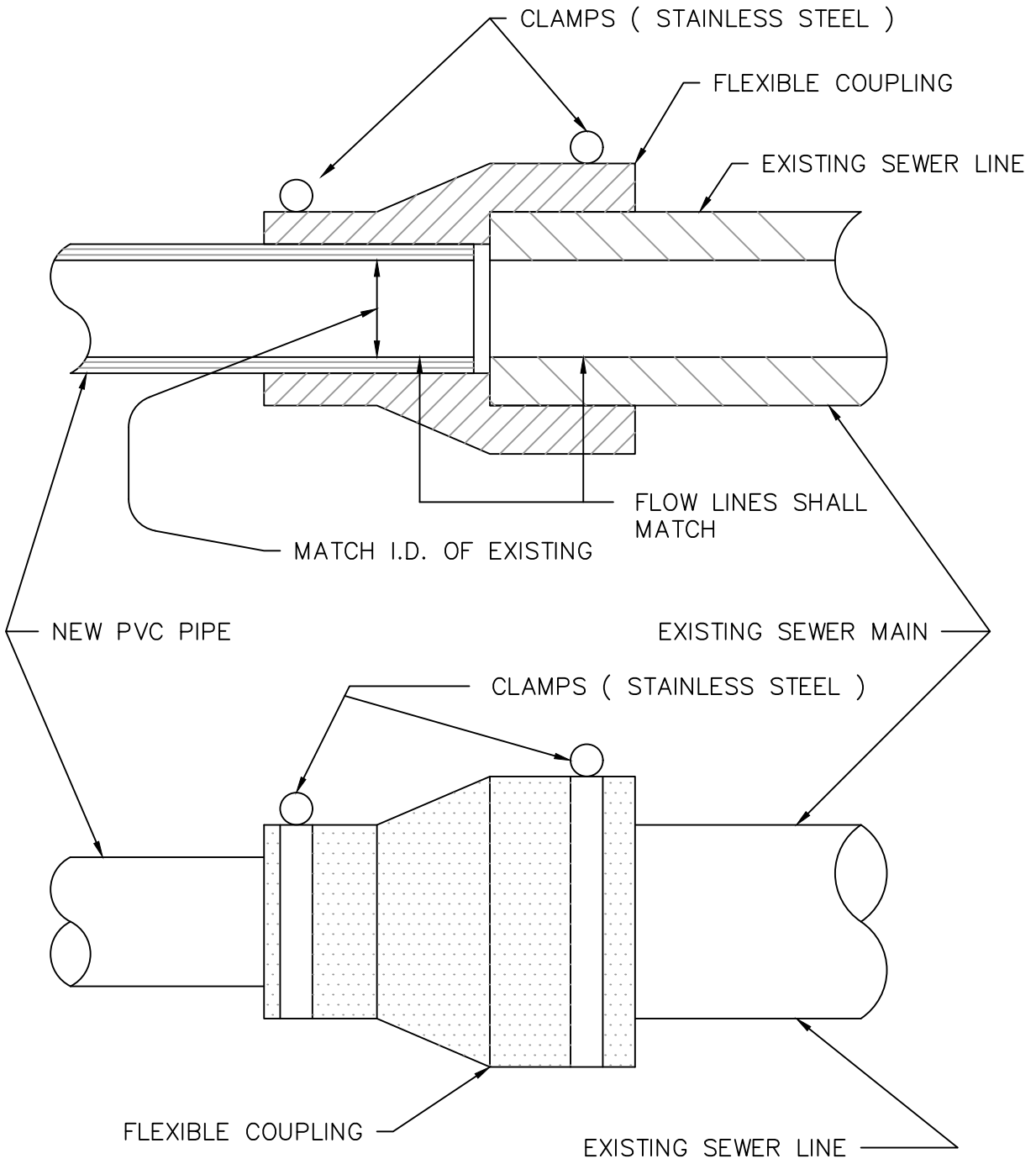

NOTE: ALL COUPLINGS SHALL BE ENCASED IN CONCRETE, INSPECTION OF COUPLING IS REQUIRED PRIOR TO CONCRETE ENCASEMENT

**SEWER REPAIR COUPLING – PVC TO CONCRETE, CLAY OR IRON**

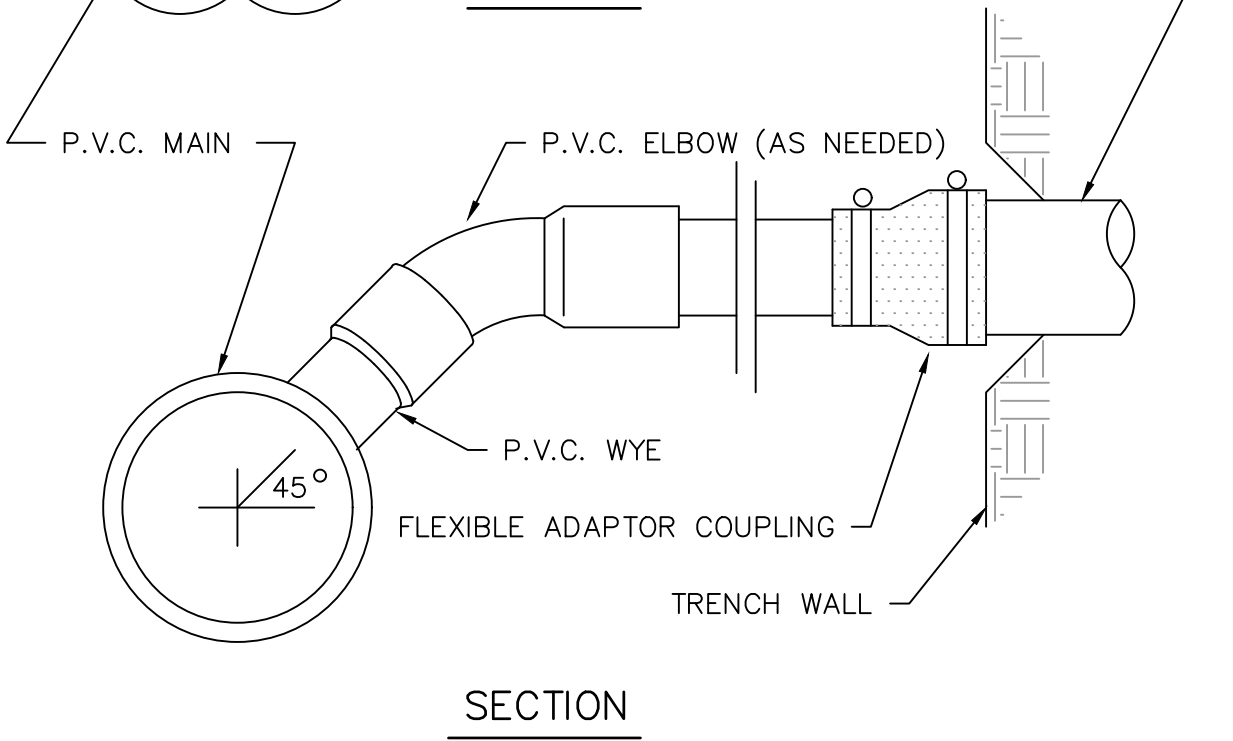
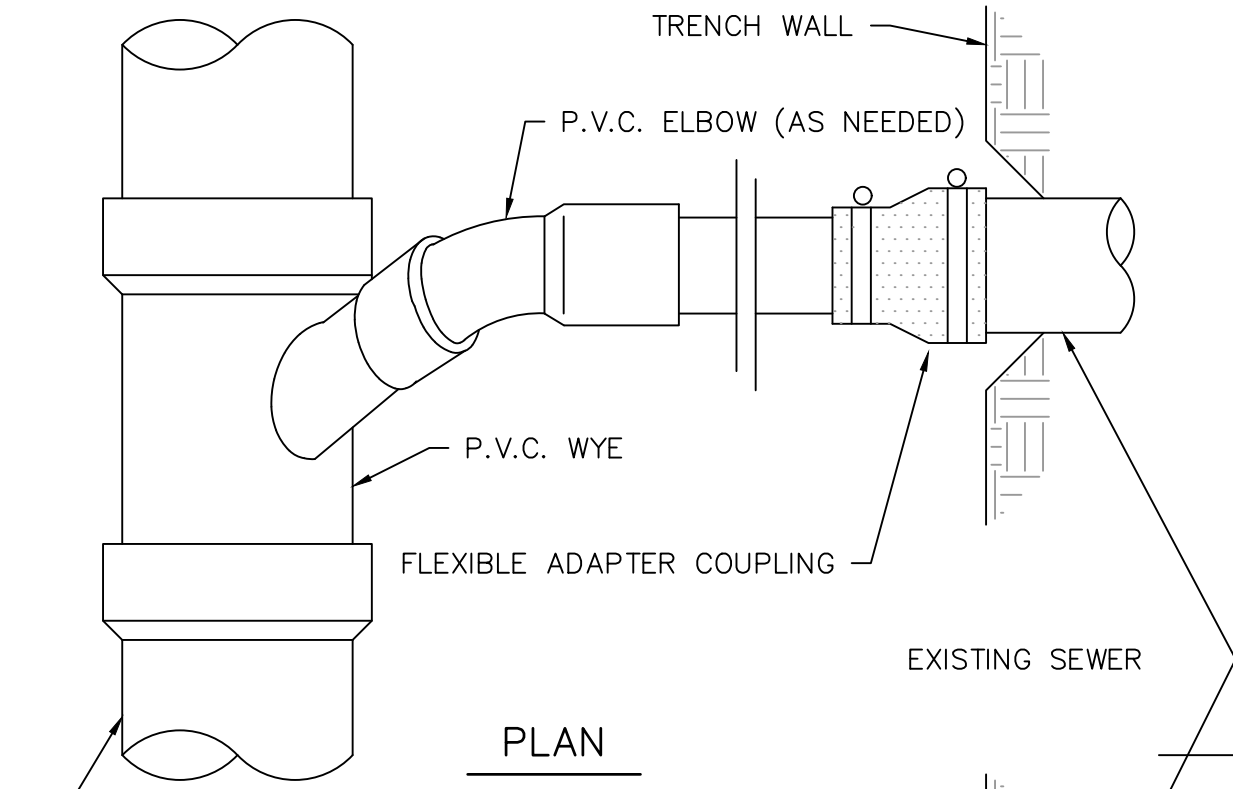

NOTES: PIPE SLOPE TO MATCH SEWER GRADE.  
 90 DEG ELBOW(S) ARE NOT REQUIRED.  
 ALL COUPLINGS SHALL BE ENCASED IN CONCRETE, INSPECTION  
 OF COUPLING IS REQUIRED PRIOR TO CONCRETE ENCASEMENT

**PVC LATERAL TO EXISTING SEWER SERVICE LINE**

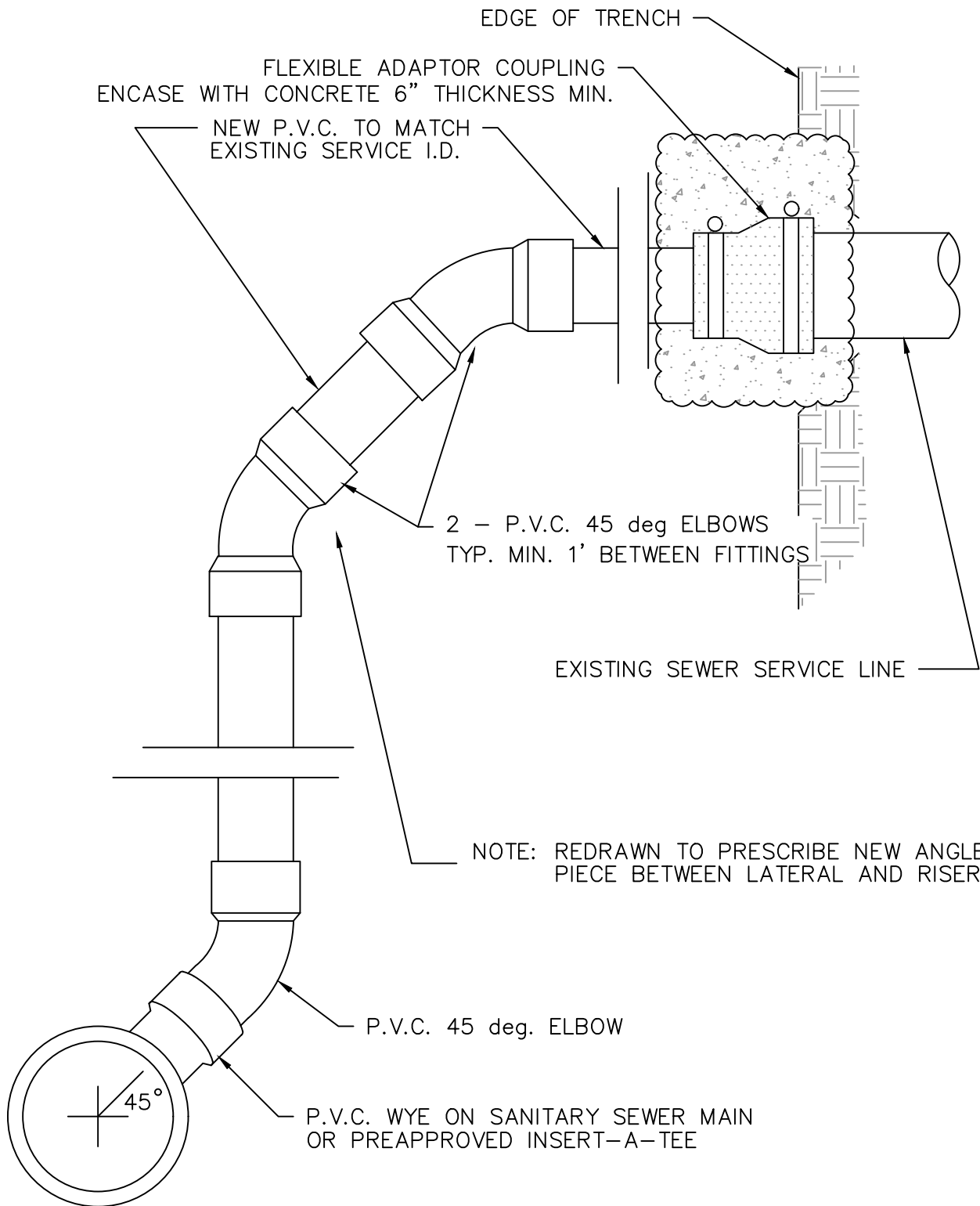

**PVC RISER LATERAL WITH RISER TO EXISTING SERVICE LINE**

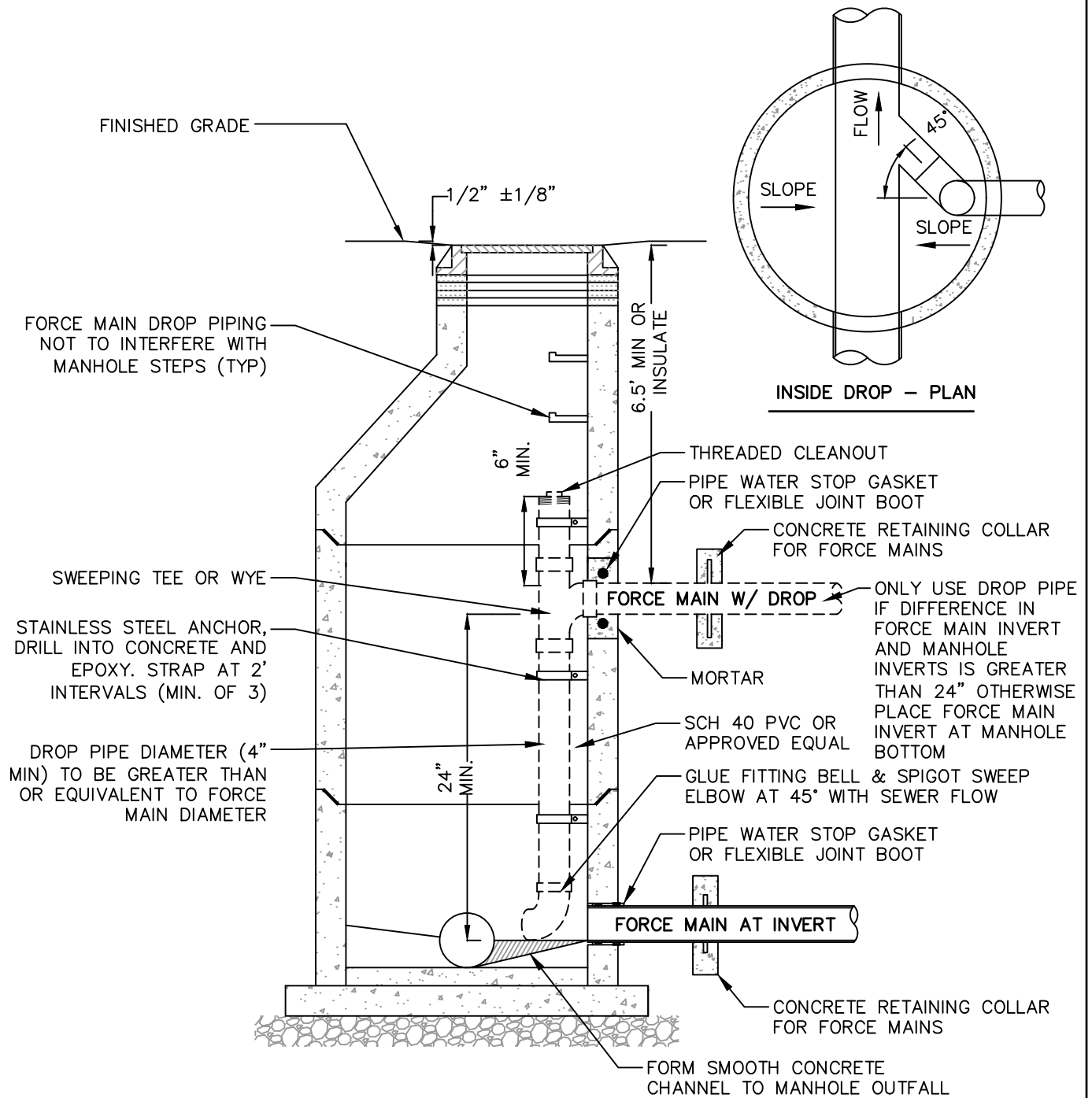

**NOTES:**

1. THIS STANDARD DETAIL SHOULD BE REVIEWED AND ADJUSTED ON A PROJECT BY PROJECT BASIS BY A LICENSED ENGINEER.
2. GRADUAL FORCE MAIN DROPS WITH PROPER AIR RELIEF OUTSIDE OF THE MANHOLE SHOULD ALSO BE CONSIDERED IF THE DESIGN WARRANTS.
3. TEST FORCE MAIN PUMPS TO ENSURE DROP PIPING IS ADEQUATELY THRUST RESTRAINED AND THAT AIR LOCK DOES NOT OCCUR IN DROP PIPING

**FORCE MAIN DISCHARGE INTO EXISTING MANHOLE**

NEENAH No. R-3067 (GRATE, FRAME & HOOD)  
OR DEETER No. 2046, OR EQUAL, WITH NEENAH  
R-3000-D ENVIRONMENTAL NOTICE PLATE OR APPROVED EQUAL  
READING "NO DUMPING, DRAINS TO WATERWAY".

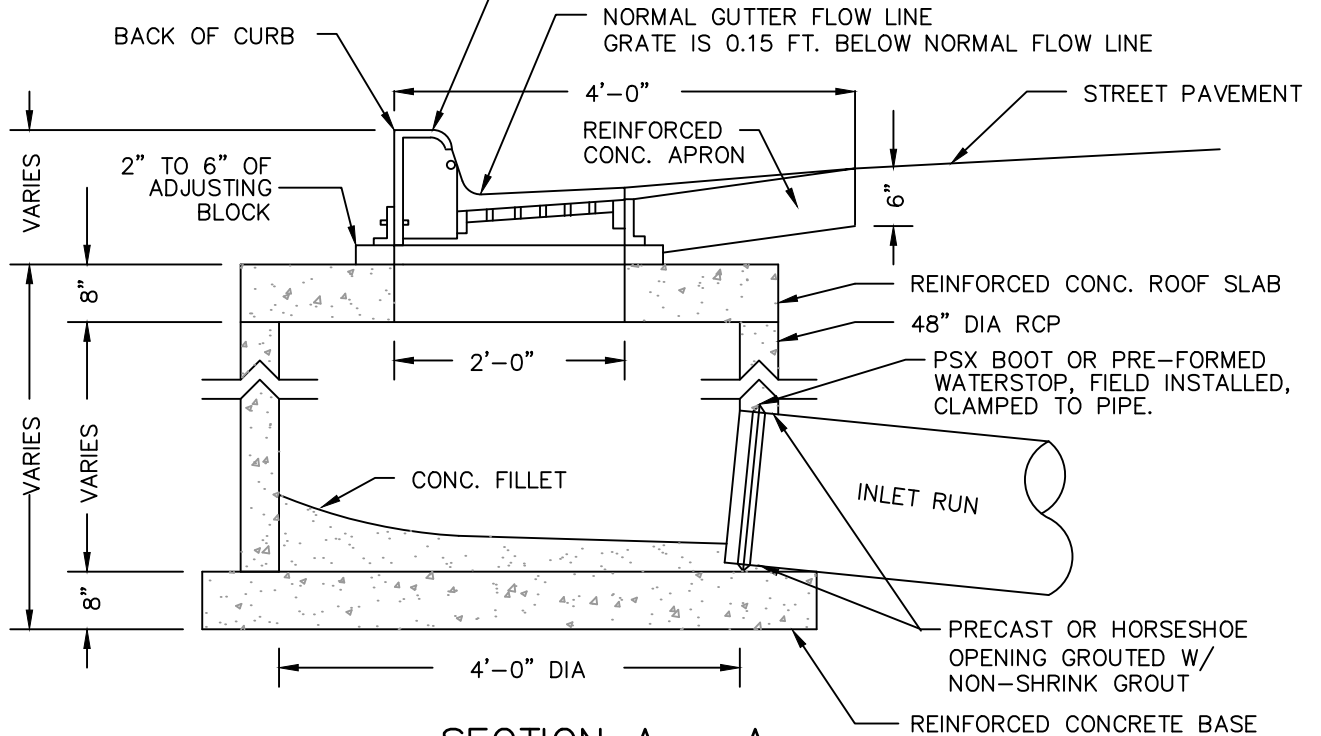

**SECTION A - A**

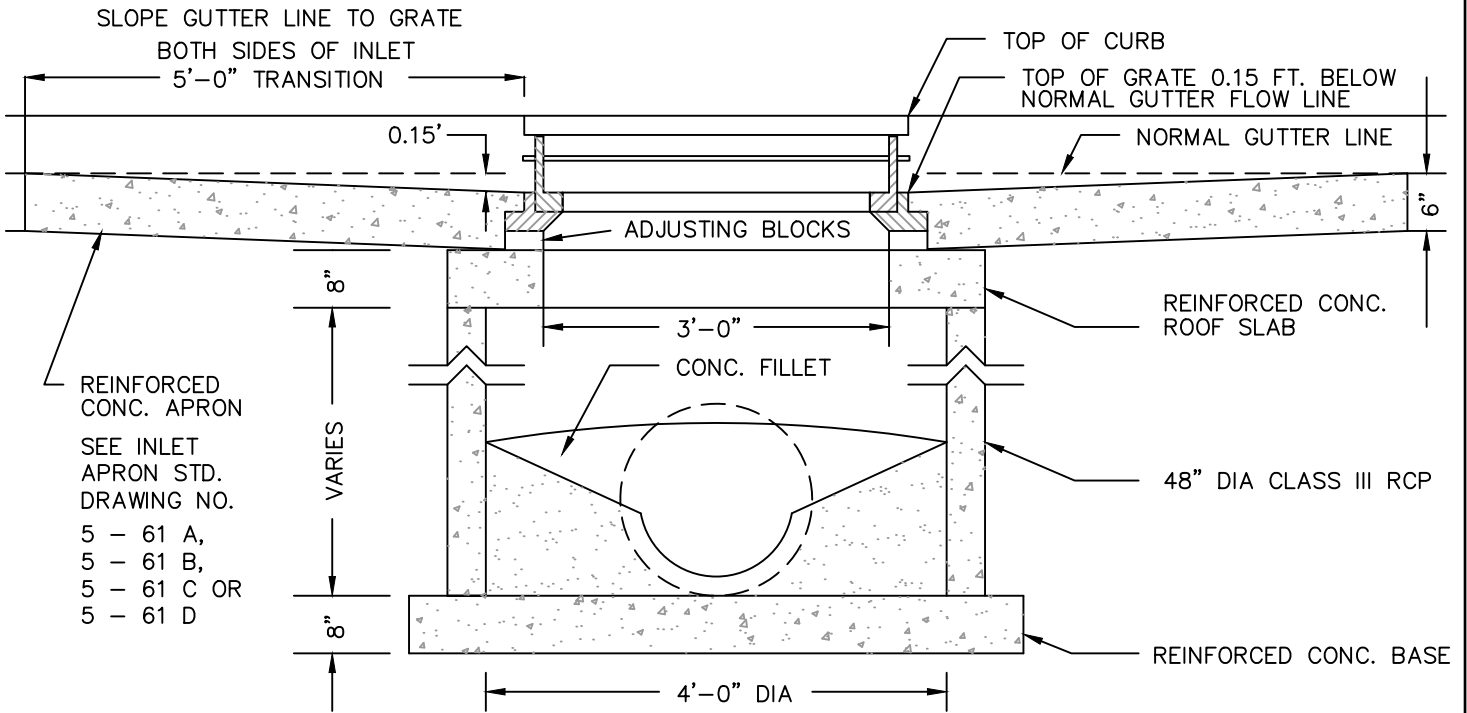

**SECTION B - B**

NOT TO SCALE

**TYPE I STORM SEWER STANDARD INLET DETAIL**



NOTE: PREVIOUS SECTION CALLOUTS REMOVED  
 NOTE: CONCRETE APRON REMOVED

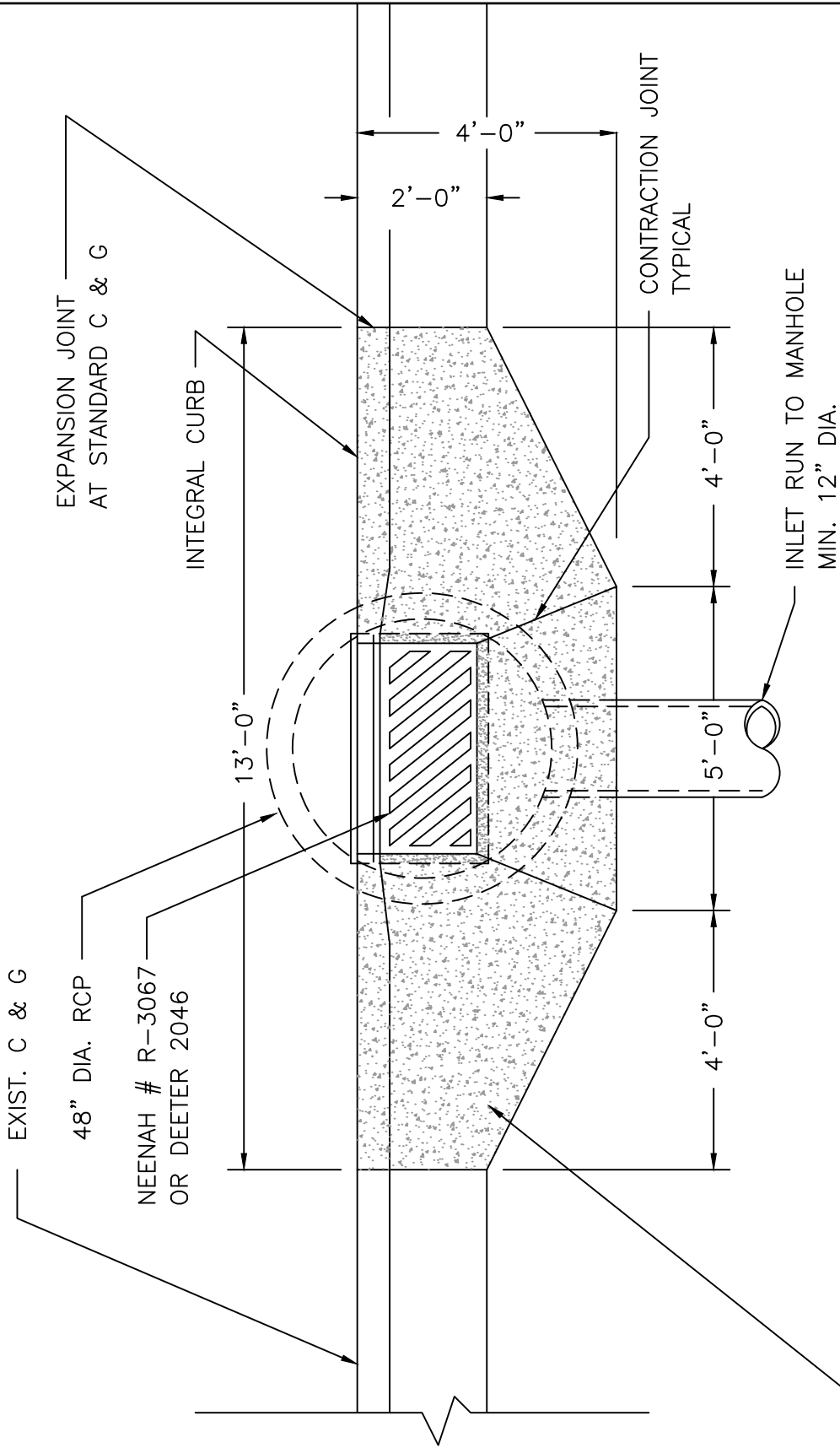

CONCRETE INLET APRON  
 # 4 BAR, 12" O.C. WITH NON-METAL CHAIRS  
 BOTH WAYS CONCRETE SHALL BE 4,000 psi  
 6" THICK W/ 8" COMPACTED BASE COURSE

NOTE: INSTALL NEENAH R-3000-D ENVIRONMENTAL NOTICE PLATE OR APPROVED EQUAL READING "NO DUMPING, DRAINS TO WATERWAY"

### TYPE I STORM SEWER INLET APRON DETAIL

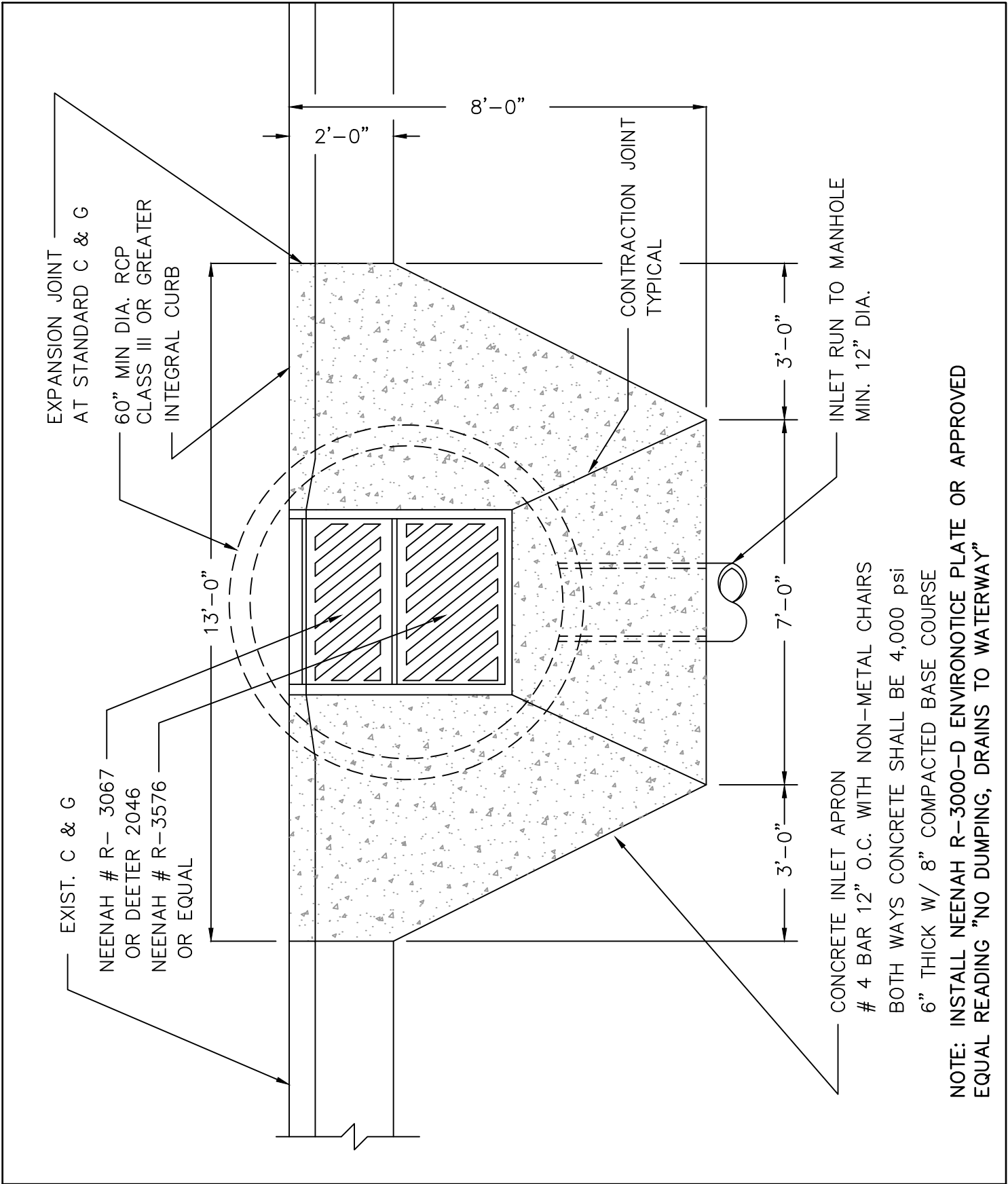

NOTE: INSTALL NEENAH R-3000-D ENVIRONMENTAL NOTICE PLATE OR APPROVED EQUAL READING "NO DUMPING, DRAINS TO WATERWAY"

TYPE II STORM SEWER INLET APRON DETAIL

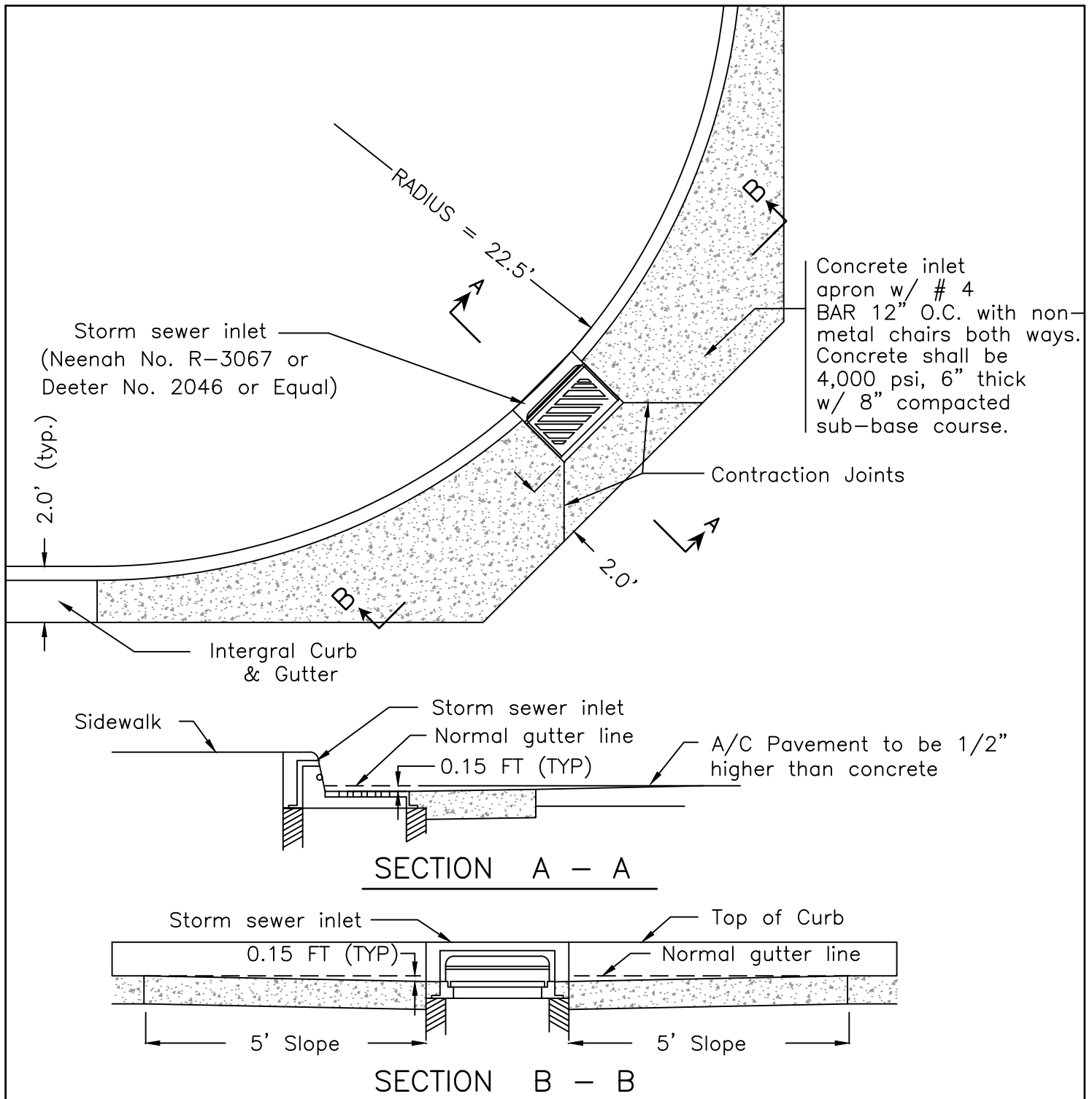

Note :

1. Inner two ft.( 2') of apron shall match TYPICAL BARRIER INTERGRAL CURB & GUTTER cross-section except for the additional slope to gutter depression at grate.
2. Slope outer portion of apron to match grade at pavement cut.
3. Install Neenah R-3000-D environotice plate or approved equal reading "NO DUMPING, DRAINS TO WATERWAY".

**TYPE I TYPICAL CORNER INLET APRON DETAIL**

Foundry No.: A-1175 or approved equal

WEIGHT OF RING = 280#  
WEIGHT OF COVER = 170#

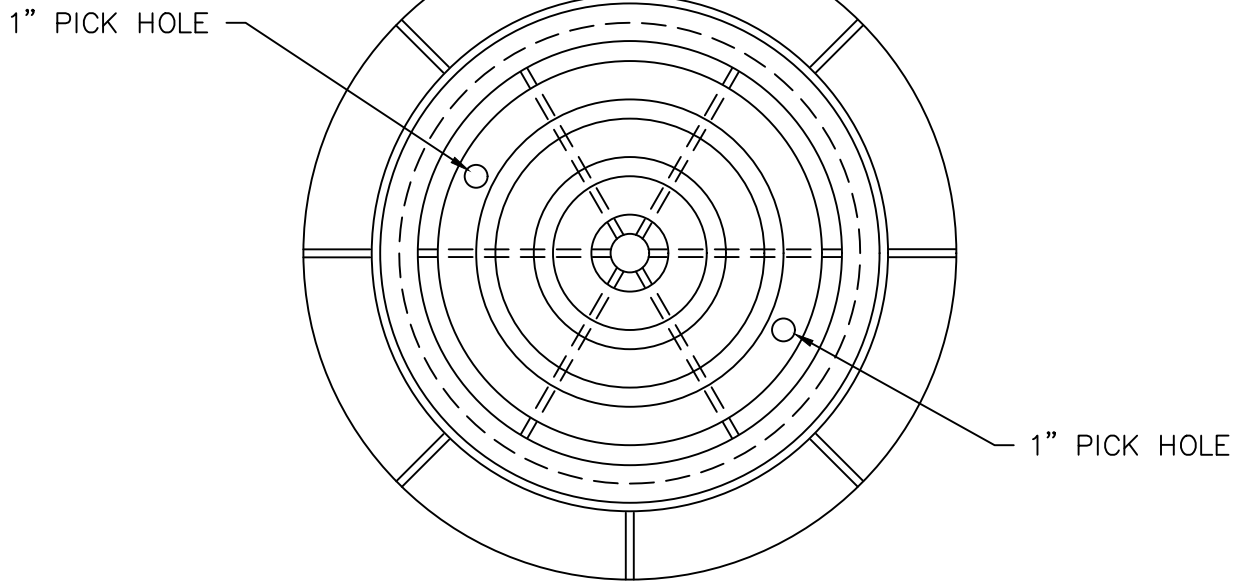

MANHOLE RING & COVER PLAN

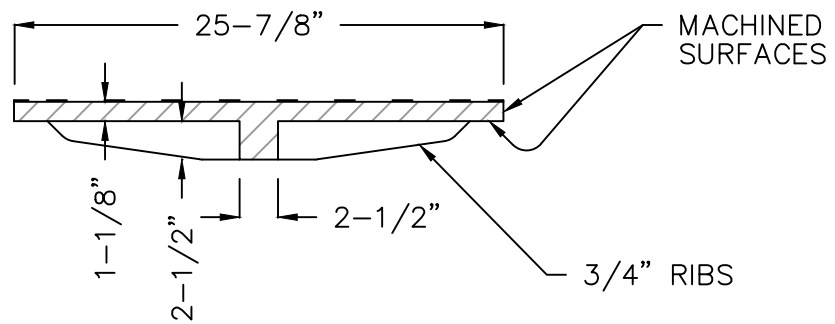

MANHOLE COVER SECTION

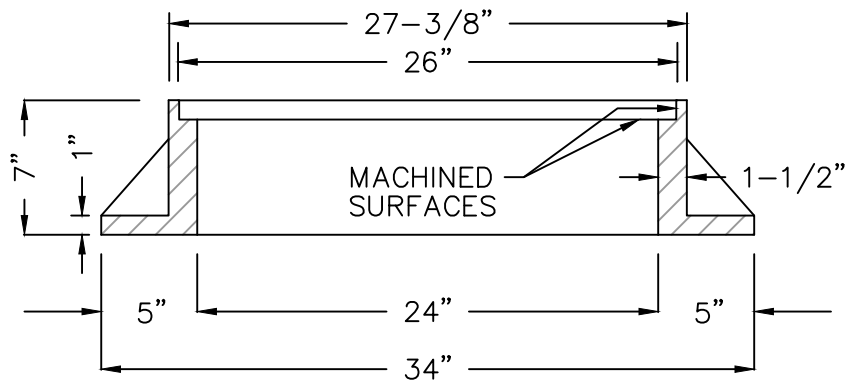

MANHOLE RING (FRAME) SECTION

### SANITARY SEWER MANHOLE RING & COVER

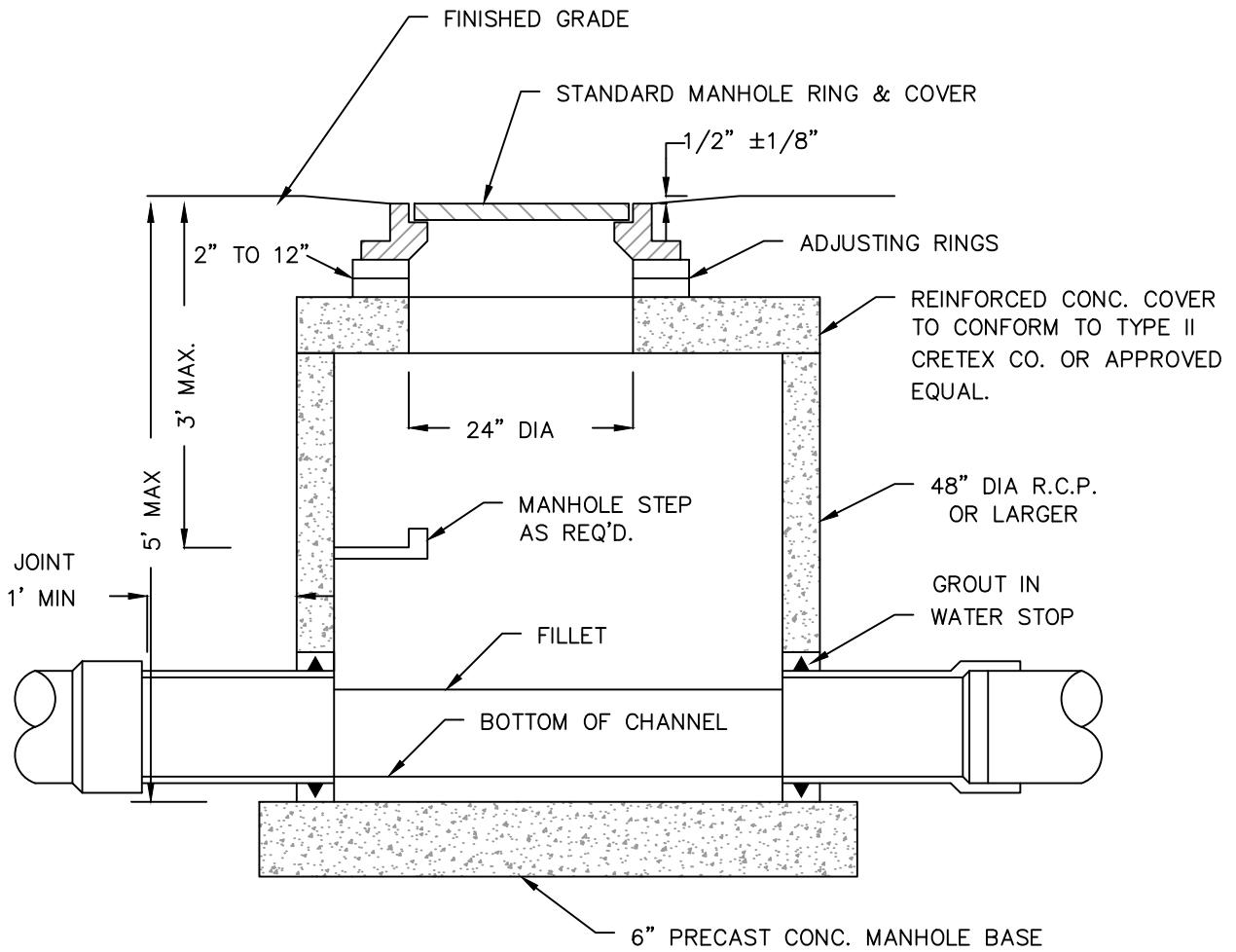

### SHORT SEWER MANHOLE

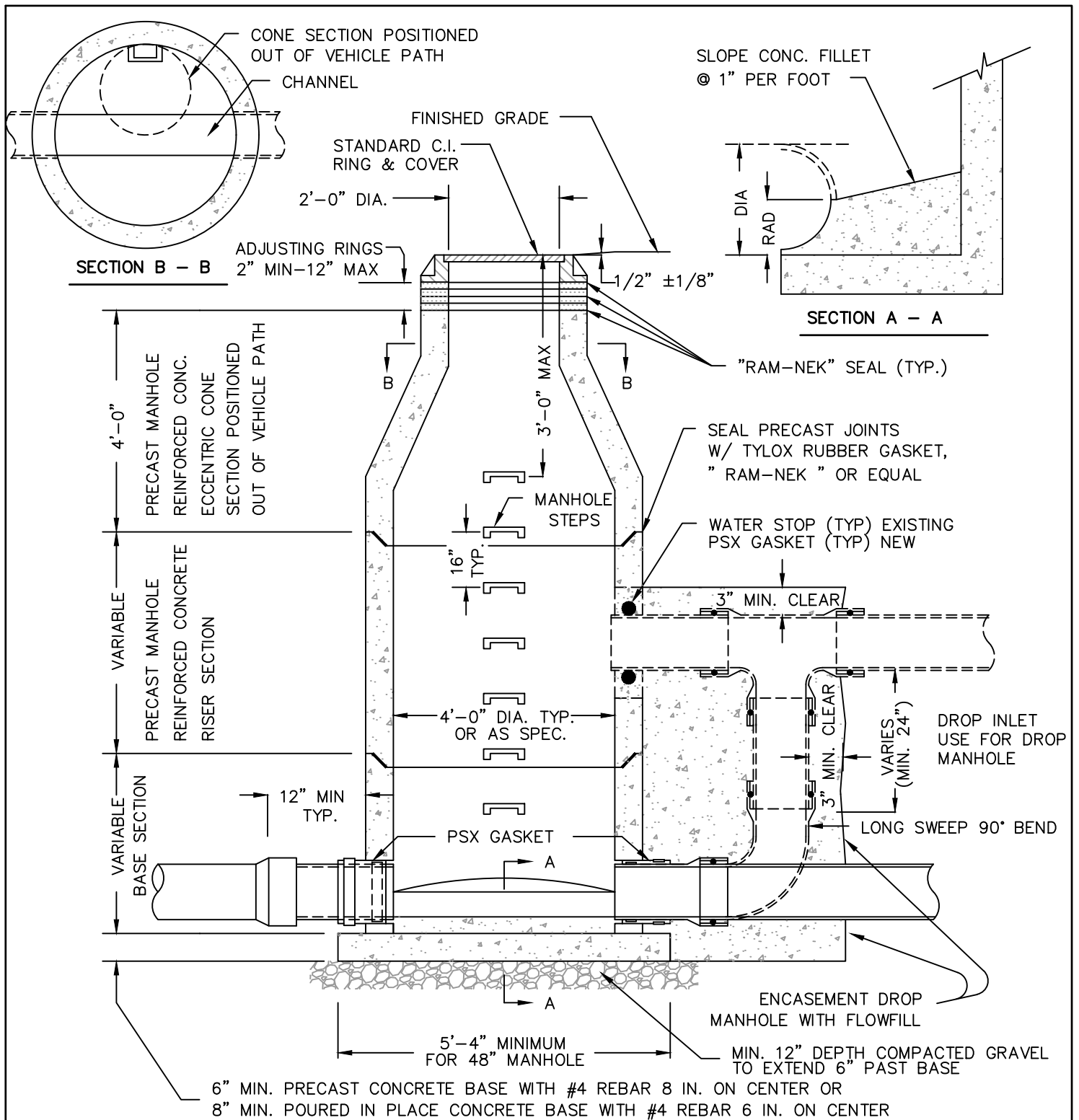

**NOTE :** ALL JOINTS BETWEEN MANHOLE SECTIONS, ADJUSTING RINGS, MANHOLE RING AND TOP SECTION, AND AROUND SEWER PIPE INTO MANHOLE SHALL BE WATERTIGHT. FOR CONNECTION TO NEW MANHOLES USE PSX OR EQUIVALENT GASKET AT ALL PIPE PENETRATIONS. FOR CONNECTIONS TO EXISTING MANHOLES USE WATERSTOP. MANHOLE CONSTRUCTION TO ADHERE TO ASTM C-478. ANY INLET DROP GREATER THAN 2.0' SHALL HAVE AN EXTERIOR INLET DROP INSTALLED.

## STANDARD SANITARY SEWER MANHOLE ( AND DROP INLET MH )

NOTE: REDRAWN TO PRESCRIBE PIPE STOPPING AT ENTRANCE AND EXIT

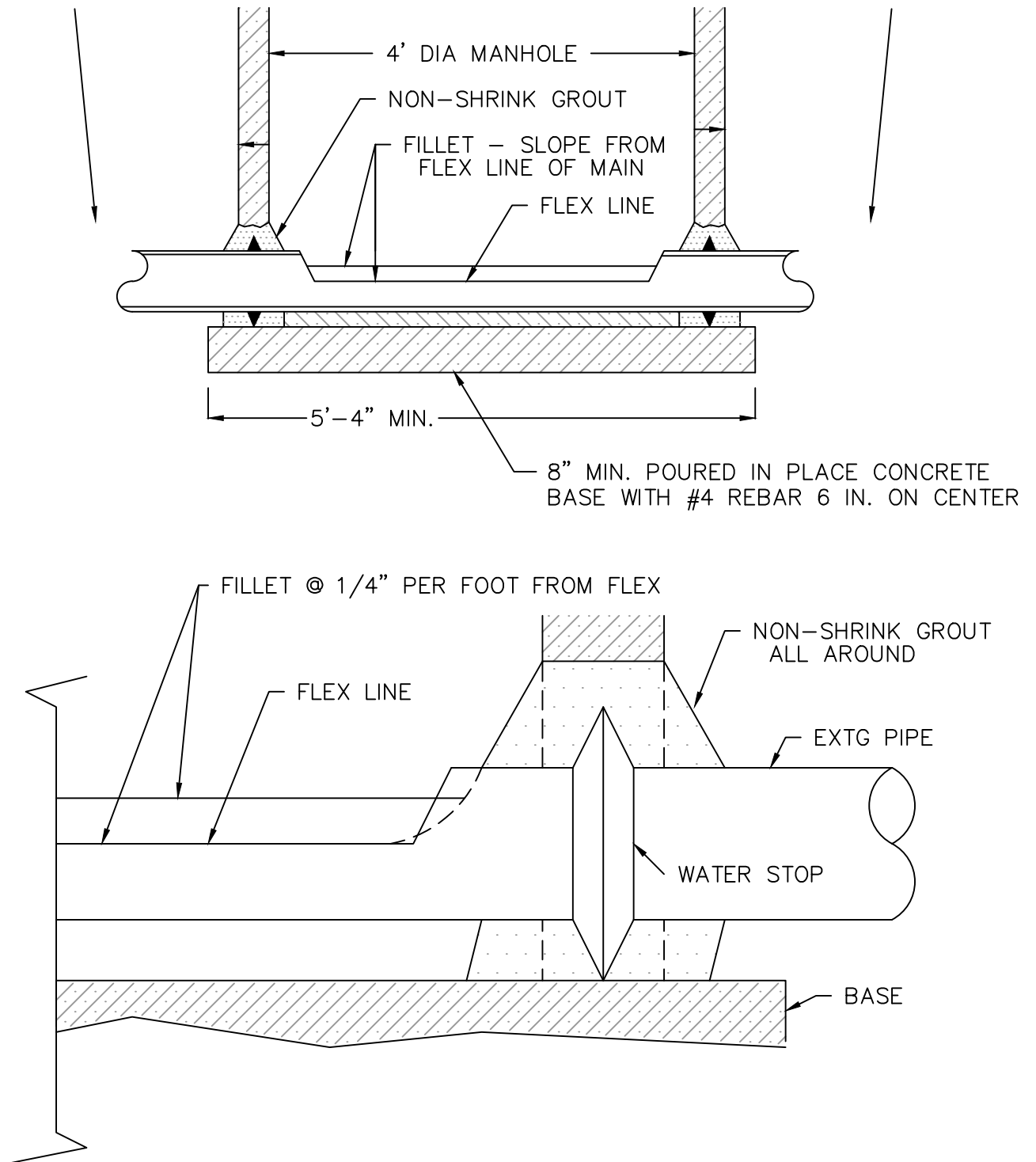

1. REMOVE UPPER 1/2 OF PIPE IN MANHOLE, CLEAN CUT EDGES.
2. SHAPE FILLET IN MANHOLE @ SLOPE OF 1/4" PER FOOT FROM PIPE FLEX TO MANHOLE PERIMETER.

## MANHOLE CONNECTION - OVER EXISTING PIPE

**SAMPLE PORTS**

1. ALL INTERCEPTORS ARE TO BE INSTALLED WITH A SAMPLING PORT THAT RECEIVES FLOW FROM THE INTERCEPTOR'S EFFLUENT.
2. TEE PIPING ON THE INTERCEPTOR'S INTERIOR WILL NOT SUFFICE AS A SAMPLE PORT.
3. SAMPLE PORTS MUST BE LOCATED IN AREAS PROTECTED FORM VEHICLE TRAFFIC.
4. SAMPLE PORTS ARE TO BE CLEANED AND INSPECTED DURING ROUTINE INTERCEPTOR PUMPING.
5. SAMPLE PORTS WILL HAVE A MINIMUM 10" DIAMETER ACCESS COVER.
6. SAMPLE PORTS WILL HAVE A MINIMUM 6" DROP BETWEEN INLET AND DISCHARGE PIPING.
7. SAMPLE PORTS MUST DRAIN COMPLETELY AND NOT HOLD WATER. BOTTOM TO BE GROUTED AND SLOPED
8. INLET PIPE PENETRATION MUST EXTEND 1" PAST THE INSIDE WALL OF THE SAMPLE PORT. PENETRATIONS ARE TO BE SEALED TO PREVENT LEAKS.

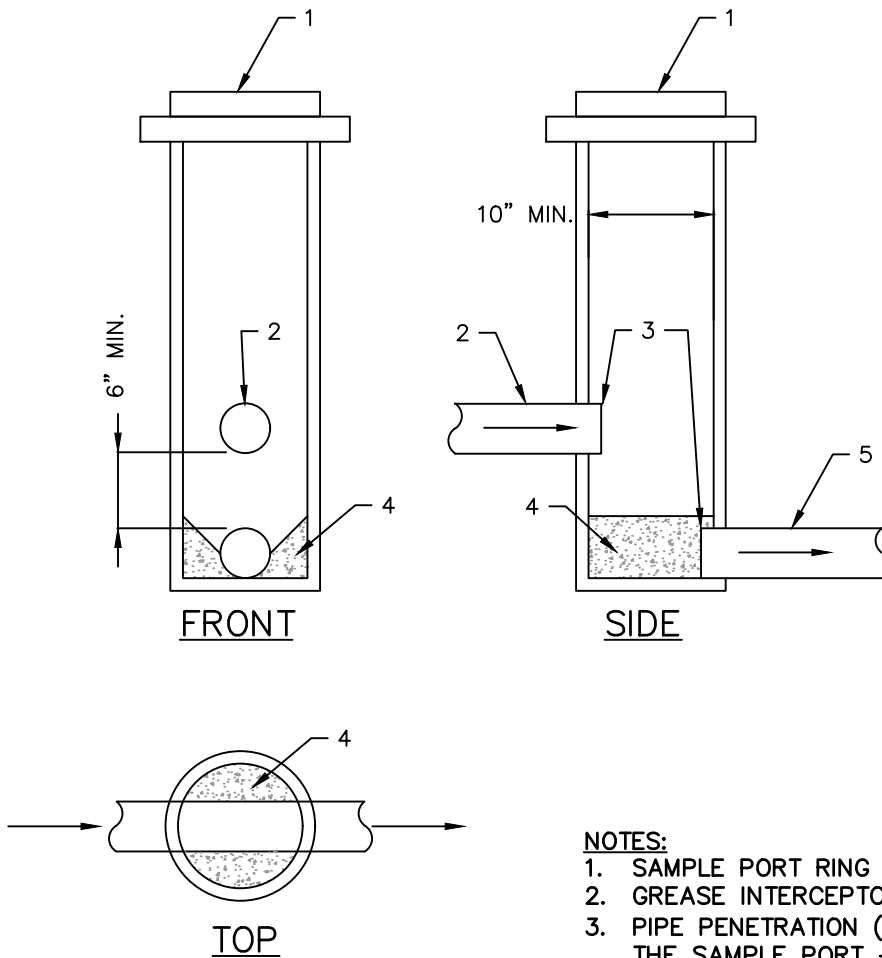

**NOTES:**

1. SAMPLE PORT RING AND LID
2. GREASE INTERCEPTOR DISCHARGE LINE
3. PIPE PENETRATION (EXTEND 1" PAST THE INSIDE WALL OF THE SAMPLE PORT – MUST BE SEALED TO PREVENT LEAKS. IF USING PVC, A SADDLE MUST BE USED)
4. GROUT (SLOPED TO WASTEWATER CHANNEL – THE SAMPLE PORT MUST DRAIN COMPLETELY AND NOT HOLD WATER)
5. SAMPLE PORT DISCHARGE LINE TO CITY'S SANITARY SEWER

**SAMPLE PORT**



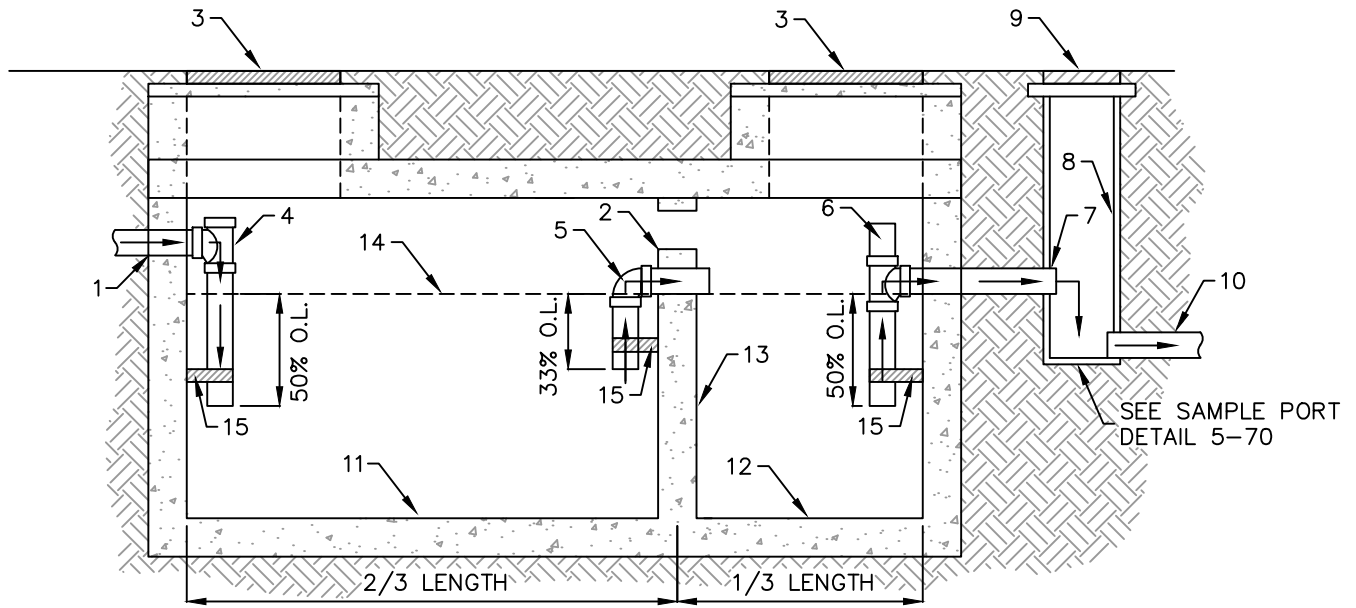

**SECTION VIEW**

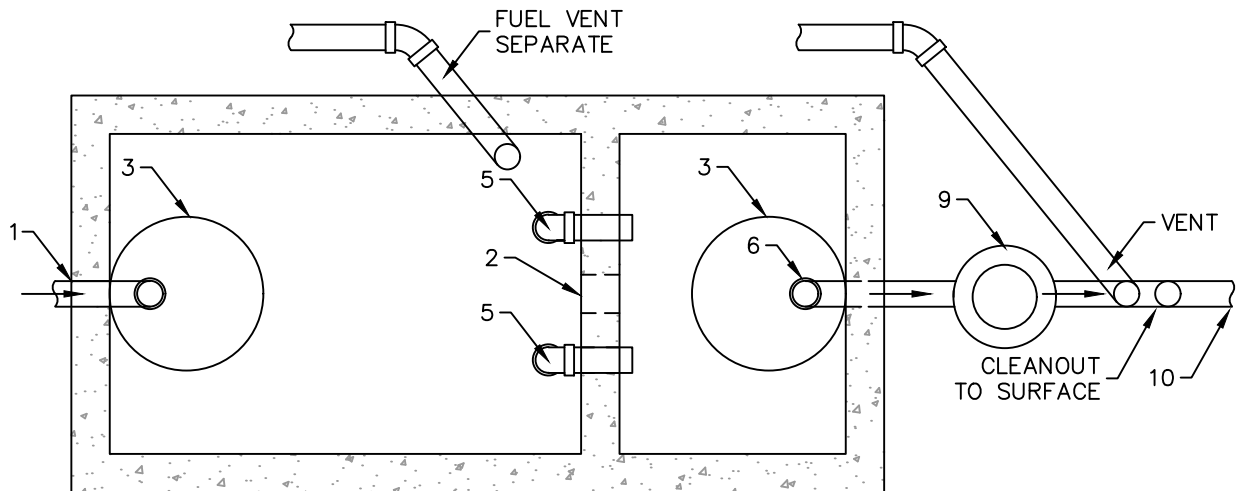

**PLAN VIEW**

**NOTES:**

1. INFLUENT LINE
2. 6" DIAMETER VENT SLEEVE
3. MINIMUM 24" OPENING, BOLTED LID WITH GASKET
4. PRIMARY CHAMBER INLET PIPING (MUST EXTEND TO 50% OF THE OPERATING LEVEL)
5. PRIMARY CHAMBER OUTLET PIPING (MUST EXTEND TO 33% OF THE OPERATING LEVEL)
6. SECONDARY CHAMBER OUTLET PIPING (MUST EXTEND TO 50% OF THE OPERATING LEVEL)
7. SAND & OIL INTERCEPTOR DISCHARGE LINE
8. SAMPLE PORT (MINIMUM 10" DIAMETER, PROVIDE A 6" VERTICAL DROP - SEE 5-70)
9. SAMPLE PORT RING AND LID
10. SAMPLE PORT DISCHARGE LINE TO CITY'S SANITARY SEWER
11. PRIMARY CHAMBER (2/3 TOTAL VOLUME). CHAMBER SHALL BE VENTED SEPARATELY
12. SECONDARY CHAMBER (1/3 TOTAL VOLUME)
13. BAFFLE
14. OPERATING LEVEL
15. PIPE SUPPORT

FOR MORE INFORMATION, CONTACT THE INDUSTRIAL  
PRETREATMENT COORDINATOR'S OFFICE AT 406-727-8390

**TYPICAL EXTERIOR SAND & OIL INTERCEPTOR**

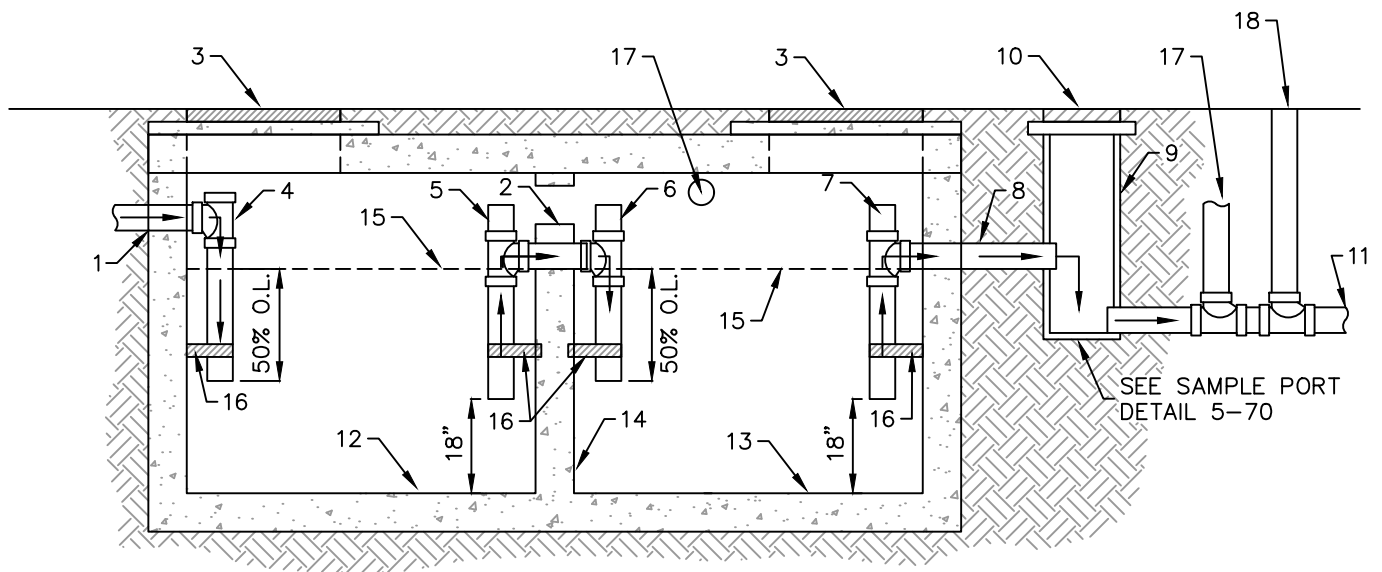

**NOTES:**

1. INFLUENT LINE
2. 6" DIAMETER VENT SLEEVE
3. MINIMUM 24" OPENING WITH RING AND LID, OR VENTED AND BOLTED GASKETED LID IN AREAS OF HIGH TRAFFIC
4. PRIMARY CHAMBER INLET PIPING (MUST EXTEND TO 50% OF THE OPERATING LEVEL)
5. PRIMARY CHAMBER OUTLET PIPING (MUST EXTEND TO 18" FROM BOTTOM OF CHAMBER)
6. SECONDARY CHAMBER INLET PIPING (MUST EXTEND TO 50% OF THE OPERATING LEVEL)
7. SECONDARY CHAMBER OUTLET PIPING (MUST EXTEND TO 18" FROM BOTTOM OF CHAMBER)
8. GREASE INTERCEPTOR DISCHARGE LINE
9. SAMPLE PORT
10. SAMPLE PORT RING AND LID
11. SAMPLE PORT DISCHARGE LINE TO CITY'S SANITARY SEWER
12. PRIMARY CHAMBER (2/3 TOTAL VOLUME)
13. SECONDARY CHAMBER (1/3 TOTAL VOLUME)
14. BAFFLE
15. GREASE INTERCEPTOR OPERATING LEVEL
16. PIPE SUPPORT
17. VENT
18. CLEANOUT

FOR MORE INFORMATION, CONTACT THE INDUSTRIAL  
PRETREATMENT COORDINATOR'S OFFICE AT 406-727-8390

## TYPICAL EXTERIOR GREASE INTERCEPTOR

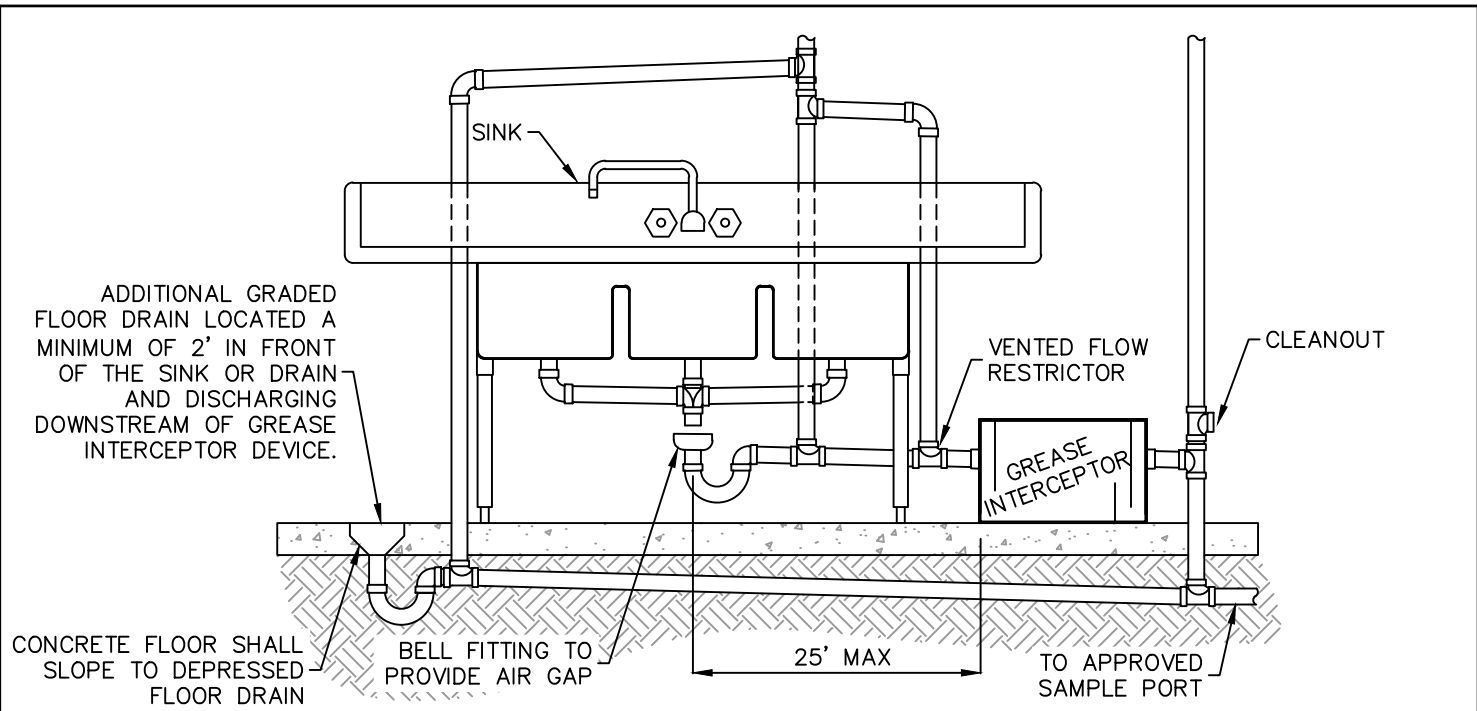

**INTERIOR ABOVE GRADE GREASE INTERCEPTOR**

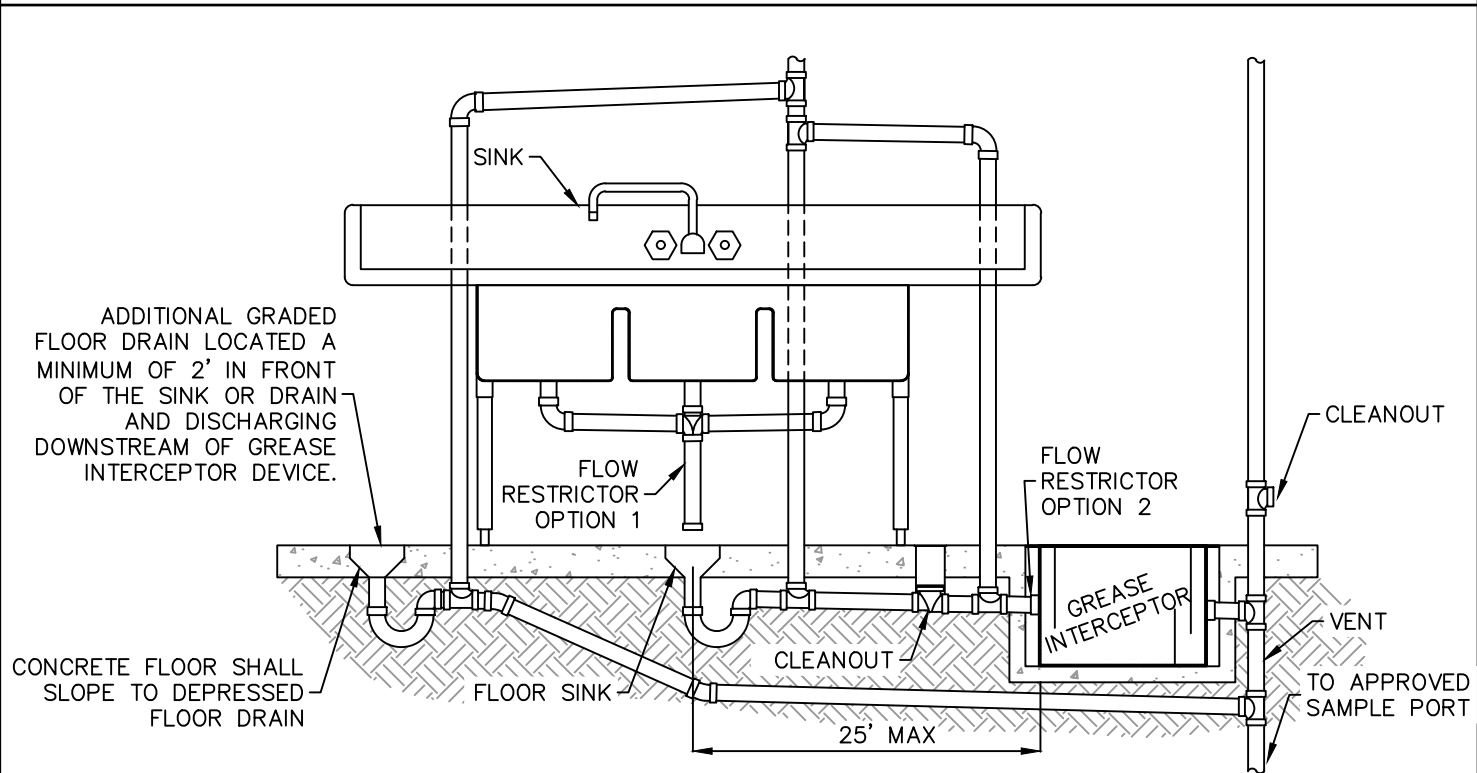

**INTERIOR BELOW GRADE GREASE INTERCEPTOR**

FOR MORE INFORMATION, CONTACT THE INDUSTRIAL PRETREATMENT COORDINATOR'S OFFICE AT 406-727-8390

**TYPICAL INTERIOR GREASE INTERCEPTORS**

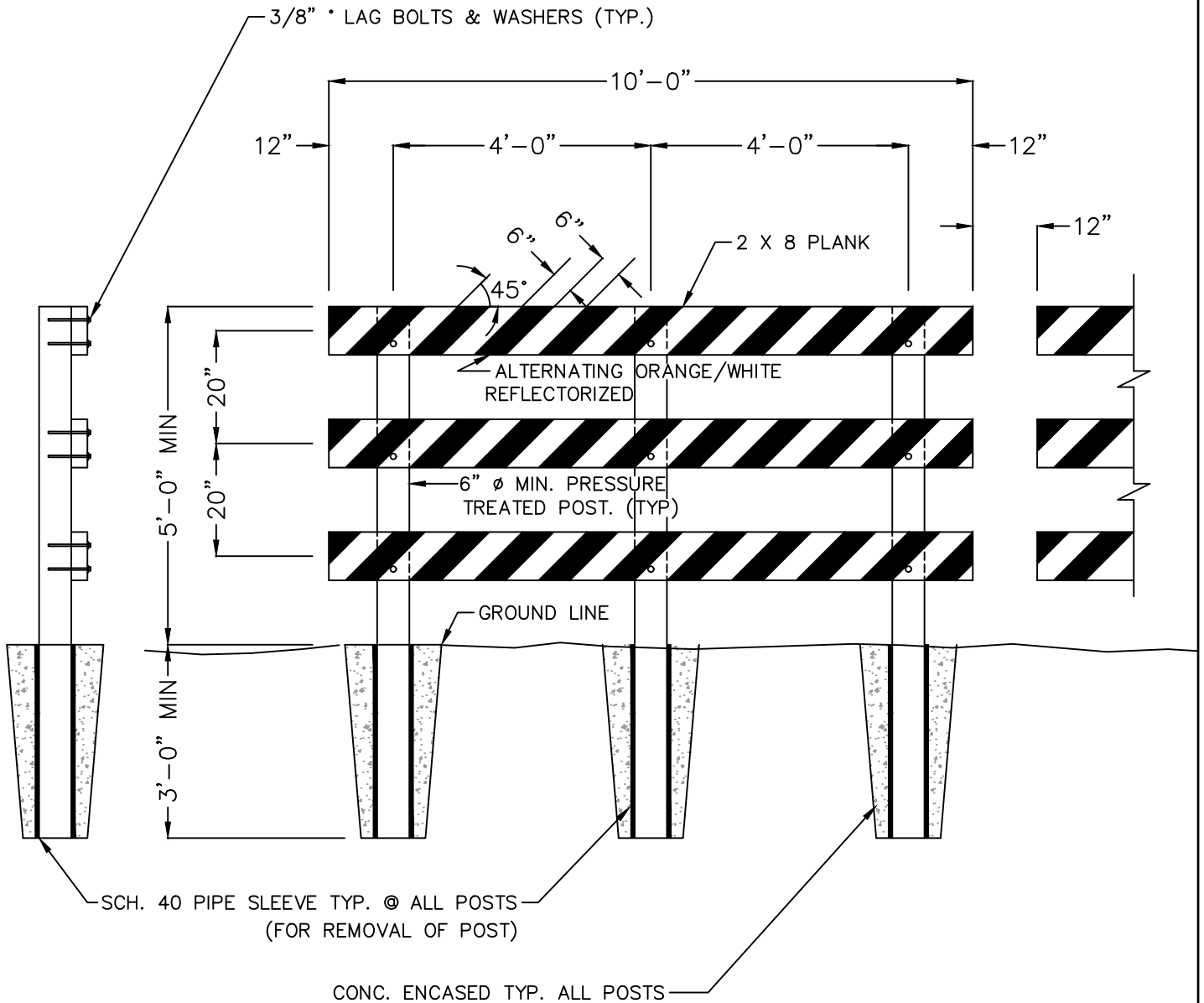

1. STRIPES SHALL SLOPE DOWNWARD IN THE DIRECTION TOWARD WHICH TRAFFIC MUST TURN.
2. USE 3/8" \* LAG BOLTS AND WASHERS. ( 6 EA PER BOARD )
3. ALL BARRICADES SHALL BE PAINTED WITH TWO COATS OF WHITE PAINT IN ACCORDANCE WITH SECTION M-280.02, (4) AND (8) OF THE STANDARD SPECIFICATION MANUAL, STATE OF MONTANA - DEPARTMENT OF HIGHWAYS.
4. ALL BARRICADES SHALL BE REFLECTORIZED WITH SHEETING MOUNTED ON A SHEET ALUMINUM BACKING AT LEAST 0.019" THICK. THIS REFLECTIVE ALUMINUM SHEETING SHALL BE SECURED WITH ALUMINUM WOOD SCREWS AND SHEETS SHALL BE THE SAME WIDTH AS 2 X 8.

## STANDARD MUTCD TYPE III FIXED BARRICADE

18"X18" DIAMOND BLACK PANEL WITH NINE  
3" RED REFLECTORS OF HIGH INTENSITY  
PRISMATIC SHEETING QUALITY

2" GALVANIZED PIPE, SCHEDULE 40, OR  
GALVANIZED STEEL U-POST, 2 LB/FT

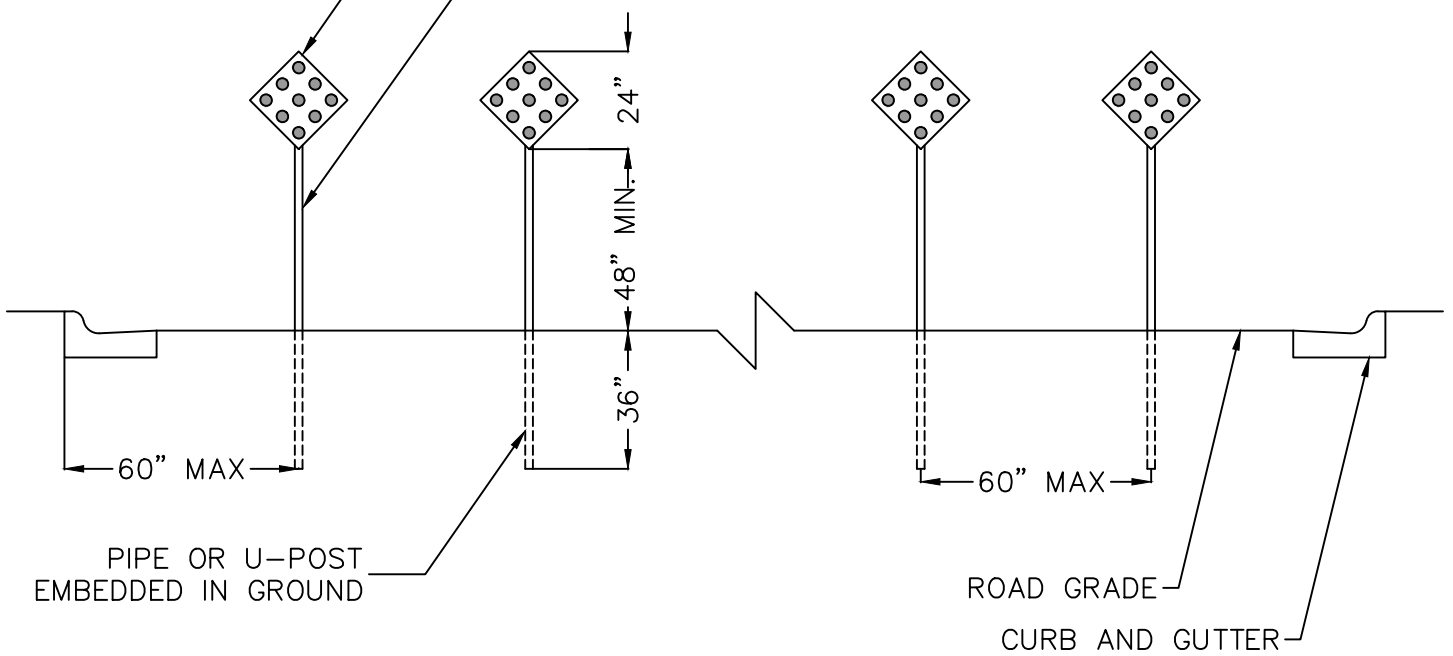

PIPE OR U-POST  
EMBEDDED IN GROUND

ROAD GRADE  
CURB AND GUTTER

CADMIUM PLATED HEX HEAD  
BOLT, WASHER, LOCKWASHER,  
AND NUT

POST MOUNTING HARDWARE

STEEL U-POST

SIGN PANEL

STEEL PIPE

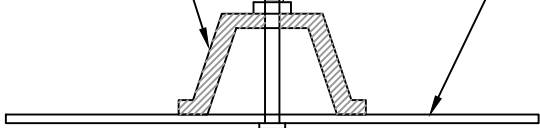

U CHANNEL CONSTRUCTION

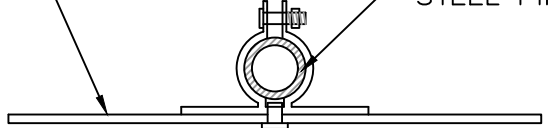

PIPE CONSTRUCTION

### DEAD END - WARNING SIGN DETAIL

# Proper Pruning Techniques

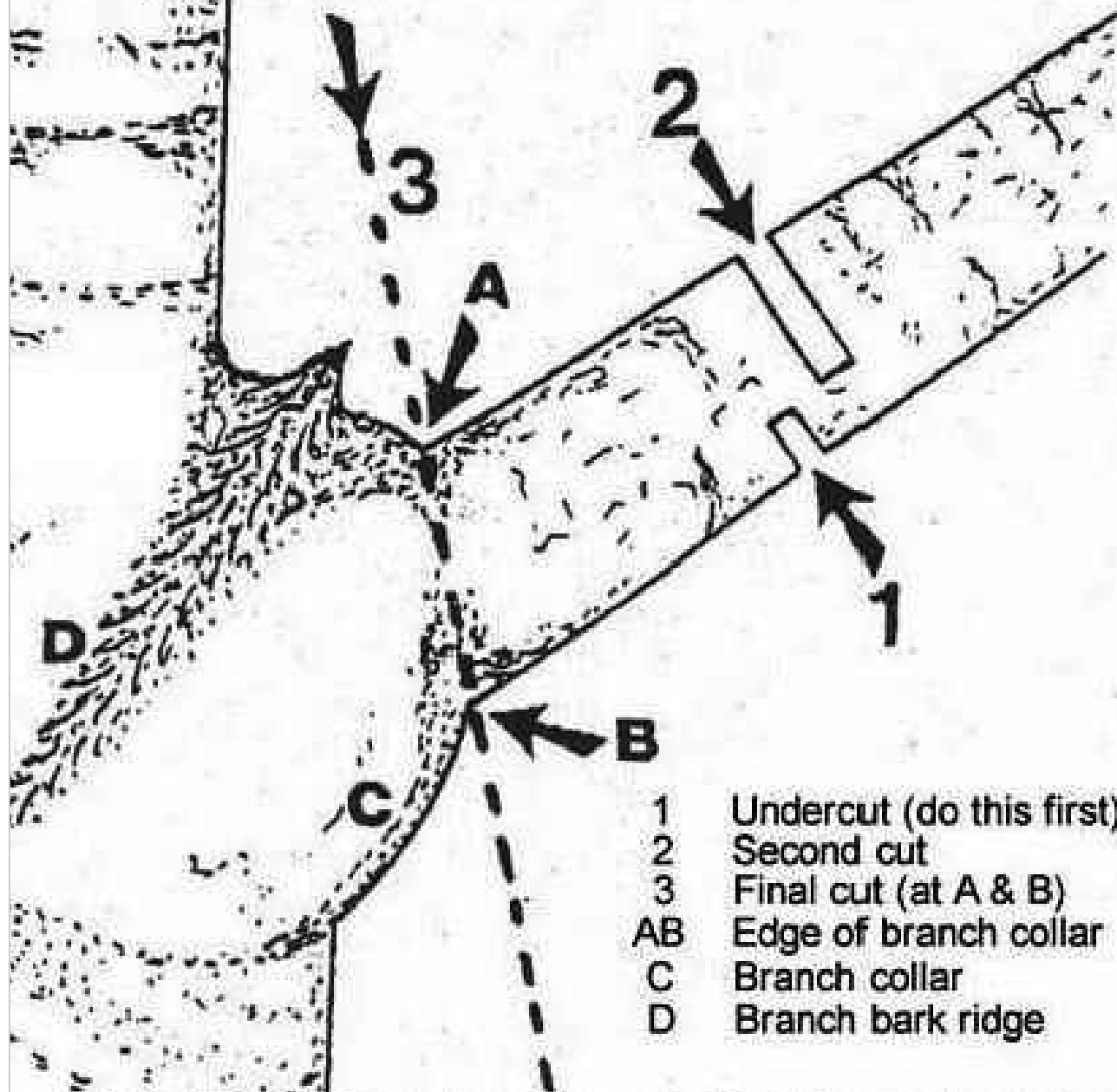

Correct pruning cuts should be made as close as possible to the branch collar. Do not injure or remove the branch collar. Do not cut behind the branch bark ridge.

## BRANCH TRIMMING