



Fire Department Access

Aerial Fire Apparatus Access

Scope and Purpose

The following Fire Department Access requirements apply to commercial and/or industrial projects where building(s) have a vertical distance between grade plane and the highest roof surface of the building in exceeds 30 feet. The highest roof surface shall be determined by measurement to the eave of a pitched roof, the intersection of the roof to the exterior wall, or the top of parapet walls, whichever is greater. If your project does not exceed this 30-foot mark, please see *Fire Department Access*.

Definition

Fire Lane – A road or other passageway developed to allow the passage of fire apparatus. A fire lane is not necessarily intended for vehicular traffic other than fire apparatus.

Fire Apparatus Access Road – A road that provides fire apparatus access from a fire station to a facility, building or portion thereof. This is a general term inclusive of all other terms such as fire lane, public-street, private-street, parking lot drive aisle, and access roadway.

Required Access

Fire Apparatus shall have access to within 150 feet of all portions of a facility and all portions of the exterior walls of the first story of the building as measured by an approved route around the exterior of a facility or building.

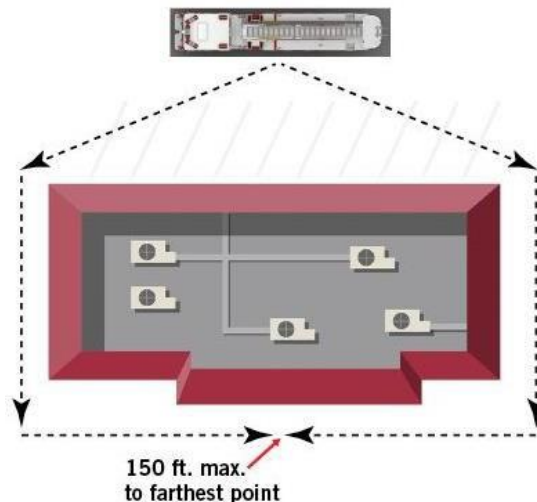

Surface

Approved Fire Apparatus Access roads shall be constructed of asphalt, concrete or other approved driving surface capable of supporting the imposed load of fire apparatus weighing at least 75,000 pounds.

Vertical Clearance

Overhead utility and power lines shall not be located over the aerial fire apparatus access road or between the aerial fire apparatus road and the building.

The Fire Code Official may allow limited obstructions that do not affect the placement or use of aerial fire apparatus, such as site vegetation or a porte-cochere at the entrance to a building. Permitted obstructions shall have an unobstructed vertical clearance of not less than 13 feet 6 inches.

Grade

- Fire apparatus access roads shall not exceed 10 percent (10%) in grade longitudinally.
- Cross slope of a road section or within a turnaround area shall not exceed five percent (5%).
- In order to accommodate proper angles of approach and departure, the gradient in fire access roads shall not exceed a five percent (5%) change along any ten (10) foot section.

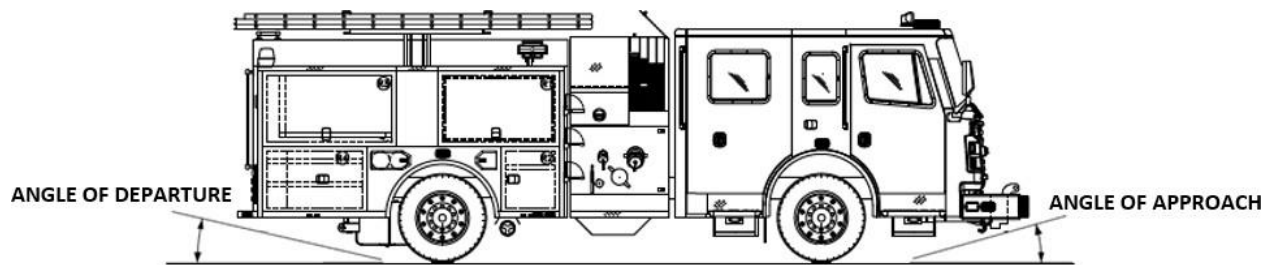

Width

A Aerial Fire Apparatus Access Road shall have a minimum unobstructed width (exclusive of shoulder) of not less than the following:

WIDTH (FEET)	
No Parking	26 feet
Parking on One Side (Parallel)	34 feet
Parking on Both Sides (Parallel)	42 feet

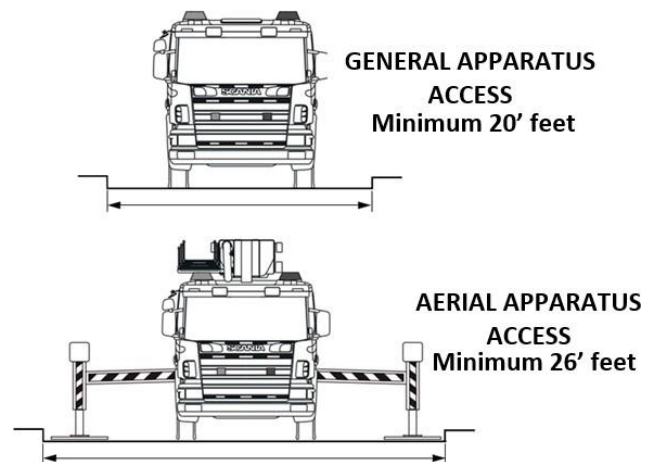

Proximity to Building

At least one of the required access routes shall be located within a minimum of 15 feet and a maximum of 30 feet from the building, and shall be positioned parallel to one entire side of the building. The side of the building on which the aerial fire apparatus access road is positioned shall be *approved* by the *Fire Code Official*.

Turning Radius

Fire apparatus access road shall be designed to accommodate the following turning radius;

- 35 foot minimum inside turning radius
- 55 foot minimum outside turning radius.

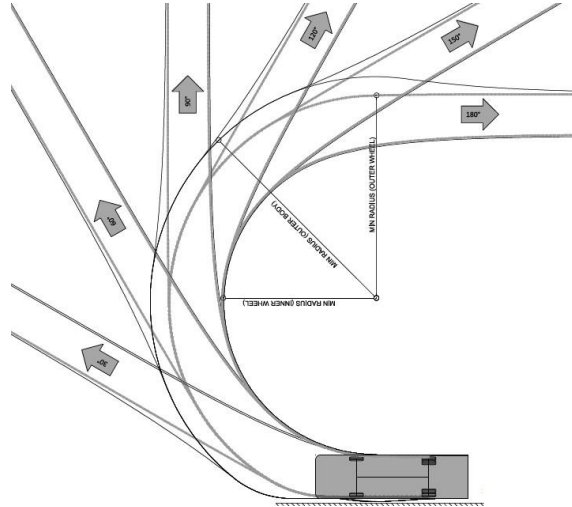

Turnarounds

A Dead-end fire apparatus access roads in excess of 150 feet shall be provided with width and turnaround provisions in accordance with International Fire Code Table D103.4 & D103.1.

TABLE D103.4
REQUIREMENTS FOR DEAD-END FIRE APPARATUS ACCESS ROADS

LENGTH (FEET)	TURNAROUNDS
0-150	Not Required
151-750	Required
Over 750	Special Approval Required

TABLE D103.1
DEAD-END FIRE APPARATUS ACCESS ROAD TURNAROUND

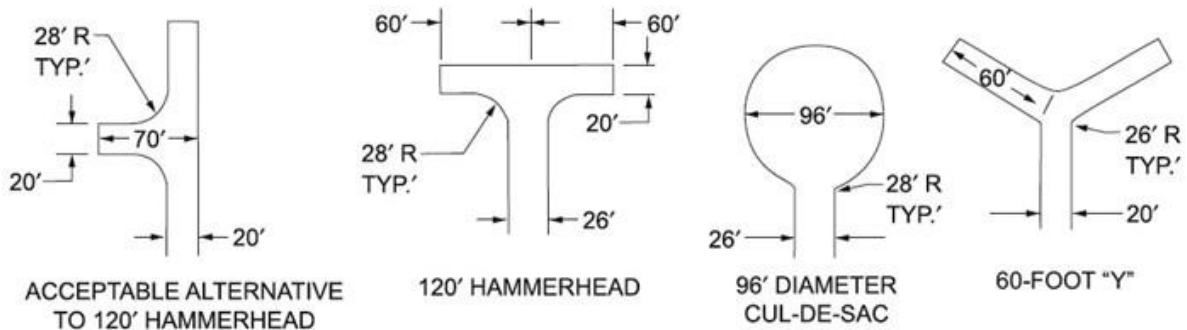

Two or More Means of Access

- Buildings or facilities having a gross building area of more than 62,000 square feet shall be provided with two separate and approved fire apparatus access roads.
- Multiple-family residential projects having more than 100 dwelling units shall have two separate approved fire apparatus access roads.
 - **Exception:** Projects having up to 200 dwelling units may have a single approved fire apparatus access road when all buildings, including nonresidential occupancies, are equipped throughout with approved automatic sprinkler systems.
- One- or two-family developments where the number of dwelling units exceeds 30 shall be provided with two separate and approved fire apparatus access roads.
 - **Exception:** When all dwelling units are equipped throughout with an approved automatic sprinkler system.
- The Fire Marshal is authorized to require more than one fire apparatus access road based on the potential for impairment of a single road by vehicle congestion, condition of terrain, climatic conditions or other factors that could limit access.
- Where two fire apparatus access roads are required, they shall be placed a distance apart equal to not less than one half of the length of the maximum overall diagonal dimension of the lot or area to be served, measured in a straight line between accesses.

Signs & Markings

See *GFFR Fire Lane Guide*

Alternate Paving Materials

Alternative paving materials such as “Grass Crete” turf block or similar type materials may be used for Fire Department Access Roads under certain conditions. When submitting for permits the applicant shall include cut sheets of the proposed alternative material and the design criteria based upon the imposed load of fire apparatus weighing of at least 75,000 pounds. The following shall comply:

- Paving shall be structurally sound to preclude movement or disbanding with soil movement.
- The paving shall be field tested by the contractor in the presence of the Fire Code Official. Testing may include driving the access road by a weight verified vehicle. Prior to testing, the soil shall be soaked for three days in a row.
- Prior to final approval, the engineer of record (civil or soils engineer) shall certify the installation.

During Construction

All required Fire Department Access Roads shall be installed to an extent that will provide all-weather paved access for emergency vehicles prior to combustibles being brought to the site or combustible construction taking place.

The *Fire Code Official* shall determine the adequacy of the access roads during construction.

Prior to final approval for any development project, fire department access roads shall be completed with all markings, signage and striping.