



City Commission Agenda

for

May 3, 2011

Please Note: The City Commission agenda format allows citizens to speak on each issue prior to Commission action. We encourage your participation. Please keep your remarks concise and to the topic under consideration.

CALL TO ORDER: 7:00 P.M.

PLEDGE OF ALLEGIANCE

ROLL CALL

PROCLAMATIONS

Bike To Work Week
Developmental Disabilities Week
Peace Officers' Memorial Day

PRESENTATIONS

Our Lady of Lourdes Science Fair Project *Jus' Recycle*

NEIGHBORHOOD COUNCILS

1. Miscellaneous reports and announcements from Neighborhood Councils.

BOARDS & COMMISSIONS

2. Appointment, Tourism Business Improvement District. Appoint one new member to fill the remainder of a four-year term through December 31, 2013.
3. Appointment, Parking Advisory Commission. Appoint one new member to fill the remainder of a three-year term through April 30, 2012.
4. Miscellaneous reports and announcements from Boards and Commissions.

PUBLIC HEARINGS

5. Ord. 3074, Grandview at Benefis (18th Avenue South and 29th Street South). Rezones property from PLI – Public Lands Institutional to PUD Planned unit development zoning district. Action: Conduct public hearing and adopt or deny Ord. 3074. (*Presented by: Mike Haynes*)

OLD BUSINESS

6. Annual Action Plan Including Use of 2011/2012 CDBG & HOME Funds. Action: Adopt or deny Plan and use of funds. (*Presented by: Mike Haynes*)

NEW BUSINESS

7. Construction Contract Award, 2011 Street Repairs. Action: Award contract in the amount of \$396,690 to Great Falls Sand & Gravel, Inc. for the 2011 Street Repairs. (*Presented by: Jim Rearden*)
8. Provisionally Accredited Levee (PAL) Agreement. Action: Approve or deny Agreement. (*Presented by: Mike Haynes*)

ORDINANCES/RESOLUTIONS

CONSENT AGENDA *The Consent Agenda is made up of routine day-to-day items that require Commission action. Items may be pulled from the Consent Agenda for separate discussion/vote by any Commissioner.*

9. Minutes, April 19, 2011, Commission meeting.
10. Total Expenditures of \$1,569,620 for the period of April 14-25, 2011, to include claims over \$5000, in the amount of \$1,372,453.
11. Contracts list.
12. Award construction contract to Phillips Construction LLC in the amount of \$388,883 for the 11th Street North Utilities Extension/Replacement.
13. Award construction contract to Liberty Electric, Inc. in the amount of \$84,653.99 for the Gibson Park Lighting.

Action: Approve Consent Agenda or remove items for further discussion and approve remaining items.

PETITIONS AND COMMUNICATIONS *(Public comment on any matter that is not on the agenda of the meeting and that is within the jurisdiction of the City Commission. Please keep your remarks to a maximum of 5 minutes. When at the podium, state your name and address for the record.)*

14. Miscellaneous reports and announcements.

CITY MANAGER

15. Miscellaneous reports and announcements from the City Manager.

CITY COMMISSION

16. Miscellaneous reports and announcements from the City Commission.

MOTION TO ADJOURN



Item: Appointment, Tourism Business Improvement District (T.B.I.D.)
From: City Manager's Office
Initiated By: City Commission
Presented By: City Commission
Action Requested: Appoint one member to the Tourism Business Improvement District Board of Trustees

Suggested Motion:

1. Commissioner moves:

“I move that the City Commission appoint _____ to the Tourism Business Improvement District Board of Trustees to fill the remainder of a four-year term through December 31, 2013.

2. Mayor calls for a second, discussion, inquiries from the public, and calls the vote.

Recommendation: It is recommended that the City Commission appoint one new member to the Tourism Business Improvement District Board of Trustees to fill the remainder of a four-year term through December 31, 2013.

Background: Deryk Copperwheat was appointed to the Tourism Business Improvement District Board of Trustees in January of 2009. Mr. Copperwheat has resigned from the Board. Therefore, it is necessary to appoint one member to fill the remainder of his term.

Purpose

The Tourism Business Improvement District was established by Resolution 9792 on December 2, 2008. Its overall purpose is to utilize tax dollars through the T.B.I.D. assessment and direct those monies to be used for the purpose of promoting tourism, conventions, trade shows, and travel to the City of Great Falls. Trustees must be an owner of property within the District or their assignee.

Evaluation and Selection Process

A notice was sent to all members included within the Tourism Business Improvement District announcing the vacancy.

Continuing members of this board are:

David Buckingham
Ryan Carroll
Bob Dompier
Malissa Hollan
Sandra Thares
Pamela Volk

Applications received from:

Bryce Baker
Becky Edwards
Scott Shull

Concurrences: The TBID Board of Directors unanimously recommended the appointment of Scott Shull.

Fiscal Impact: Not applicable.

Alternatives: Seek alternative applications.

Attachments/Exhibits: Applications
TBID recommendation letter
(Attachments not available online; on file in City Clerk's Office.)



Item: Appointment to the Parking Advisory Commission

From: City Manager's Office

Initiated By: City Commission

Presented By: City Commission

Action Requested: Appoint one new member to the Parking Advisory Commission

Suggested Motion:

1. Commissioner moves:

“I move that the City Commission appoint _____ to fill the remainder of a three-year term through April 30, 2012, to the Parking Advisory Commission.”

2. Mayor calls for a second, discussion, inquiries from the public, and calls the vote.

Staff Recommendation: Staff recommends that one member be appointed to the Parking Advisory Commission to fill the remainder of a three-year term.

Background: Jose “Marty” Martinez resigned from the Commission; therefore, it is necessary to appoint one member to fill the remainder of his term.

At the March 15, 2011, City Commission meeting, an agenda item was presented to appoint one member to fill this vacancy. At that time, only one application was received. By a 5-0 vote, staff was directed to re-advertise for a period of 30 days to see if there were other interested citizens. After the 30-day deadline, no other applications were received.

Purpose.

The Parking Advisory Commission is comprised of five members appointed by the City Commission. The Commission advises the City Commission, City Manager, and Planning and Community Development Staff on matters related to parking issues within the Parking Districts.

Evaluation and Selection Process

Announcements regarding the opening were placed in the *Great Falls Tribune* and on the City's Website. One application was received from Charles Bruckner. Mr. Bruckner currently serves on the Park and Recreation Board. Resolution 9910, adopted by the City Commission on February 15, 2011, states, “Citizens may not serve on two or more boards simultaneously unless

authorized by the City Commission.” There is not a scheduling conflict, as the Park and Recreation Board meets on the 2nd Monday of each month, and the Parking Advisory Board meets on the 3rd Monday of each month.

Continuing member of this board is:

Daren Brown
David Campbell
Charles Fulcher
Phil Kiser

Citizens interested in serving on this Board:

Charles Bruckner

Concurrences: Not applicable.

Fiscal Impact: Not applicable.

Alternatives: Continue advertising to seek further citizen interest.

Attachments/Exhibits: Board Application (Not available online; on file in City Clerk's Office.)



Item: Ordinance 3074 to rezone Lots 1A1 and 1B2, Mount Olivet Addition, Section 17, Township 20 North, Range 4 East, P.M.M., Cascade County, Montana known as The Grandview at Benefis

From: Jana Cooper, RLA, Planner II, Planning and Community Development

Initiated By: Benefis Health System, Property Owner and Developer

Presented By: Mike Haynes, AICP, Director of Planning and Community Development

Action Requested: Conduct public hearing and adopt Ordinance 3074

Public Hearing:

1. Mayor conducts public hearing, calling three times each for opponents and proponents.
2. Mayor closes public hearing and asks the will of the Commission.

Suggested Motion:

1. Commissioner moves:

“I move that the City Commission (adopt/deny) Ordinance 3074.”

2. Mayor calls for a second, discussion, and calls for the vote.
-

Recommendation: At the conclusion of a public hearing held on February 22, 2011, the Zoning Commission passed a motion recommending the City Commission rezone The Grandview at Benefis described as Lots 1A1 and 1B2, Mount Olivet Addition from PLI – Public Lands Institutional to PUD Planned Unit Development zoning district subject to fulfillment of the conditions of the staff report.

Planning staff’s recommendation to the Zoning Commission was to approve the rezoning of the subject property. One citizen spoke as an opponent of The Grandview at Benefis, no one spoke as proponents and three provided general comment.

Background: The ±42.9 acre subject property is generally located at 18th Avenue South & 29th Street South. The developer is requesting approval of a rezoning of the subject property from PLI - Public Lands and Institutional to PUD - Planned Unit Development.

The proposed PUD is broken down into three zones that consist of a variety of uses for a Continuing Care Retirement Community. These uses will offer several levels of health care on one campus including the following accommodations:

Independent Living Community: residents who live on their own and do not need personal assistance.

- Up to 160 apartments. The apartment buildings will be three stories with structured parking on a level below grade.
- Up to 36 independent living detached homes ranging from 1,250 to 1,660 square feet plus an attached two-car garages.

Assisted Living Community: for people who require help with the activities of daily living.

- Up to 96 studio or one-bedroom apartments in multi-unit apartment buildings.

Special Care (memory impaired):

- Up to 16 units, attached or free standing households.

Skilled Nursing Households:

- Up to 48 beds, skilled nursing households surrounding a central atrium or are free standing.

Adult Day Care:

- Adult day care is a planned program of activities designed to promote well-being through social and health related services. The adult day care center is proposed in Zone 2 of the PUD.

The intent of the proposed PUD is to provide housing and related facilities to serve the needs of people age fifty-five (55) years and older. The PUD divides the site into three zones in order to establish varying densities and mix of housing types that will meet the needs of the residents.

The proposed uses and development standards for each zone are broken down as follows:

Zone One: Zone One is comprised of approximately 12.8 acres and is generally located in the northwest corner of the site. The primary uses include Nursing Care, Special Care (memory support) and Assisted Living. The standards for zone one include:

- Maximum Dwelling Units per Acre: 14 units per acre
- Minimum Property Setback: 80 feet
- Minimum Internal Building Setback: 20 feet
- Maximum Building Coverage: 35 percent
- Off Street Parking Requirements: 1 space per 5 nursing beds and 1 space per employee per shift.
- Maximum Building Height: 45 feet

Zone Two: Zone Two is comprised of approximately 16.7 acres and is generally located in the center of the site. The primary uses include Multi-family Apartment Building and Community Commons Building. The standards for zone two include:

- Maximum Dwelling Units per Acre: 12 units per acre
- Minimum Property Setback: 150 feet
- Minimum Internal Building Setback: 15 feet

- Maximum Building Coverage: 20 percent
- Off Street Parking Requirements: 1.25 spaces per apartment 1 space per 200 square feet of net assembly, dining and activity space and 1 space per employee per shift.
- Maximum Building Height: 56 feet for the Apartment building and 45 feet for the Community Commons building.

Zone Three: Zone Three is comprised of approximately 13.4 acres and is generally located in the south of the site. The primary uses include detached one-story single family homes. The standards for zone three include:

- Maximum Dwelling Units per Acre: 3 units per acre
- Minimum Property Setback: 60 feet
- Minimum Internal Building Setback: 20 feet
- Maximum Building Coverage: 25 percent
- Off Street Parking Requirements: 2 car garage per each detached dwelling unit and a driveway large enough to park 2 cars without blocking sidewalks.
- Maximum Building Height: 28 feet

The Grandview at Benefis property is adjacent to 29th Street South and 18th Avenue South both streets are paved and have curb and gutter. The developer will be required to provide engineering drawings that complete and bring these roads into compliance with City Standards.

The internal streets of the proposed PUD are planned to be privately owned and maintained. The streets are 28 feet wide back of curb to back of curb; allowing one driving lane in each direction and parking on one side of the road. The drive lanes in areas with 90 degree parking spaces are proposed to be 24 feet wide.

In order to provide for effective east-west movements through the area, as well as to serve the residents, employees and visitors to the project for the proposed PUD, it will be necessary to construct an east-west roadway through the area. The Medical District Master Plan, adopted by City Commission in January 2007, anticipated that 15th Avenue South and 18th Avenue South would be extended east to connect to 32nd Street South to provide east-west connections.

The extension of 18th Avenue South would bisect the Grandview at Benefis property and is inconsistent with the concept for the project. As an alternative to this on-site improvement, Planning and Public Works staff supports completing 15th Avenue South from its current terminus east of 29th Street South to 32nd Street, which is a more critical link in the roadway network. Benefis has committed to making the 15th Avenue South connection. Depending on acquisition of a missing segment of ROW, the entire connection may be designed and constructed by Benefis or a portion may be designed and constructed by Benefis with funds escrowed for construction of the remaining segment upon acquisition of said ROW.

The Development Agreement (Exhibit E) includes specifics regarding how and when the 15th Avenue South extension will be completed.

In summary, if the City can acquire the ±400 foot ROW in a timely manner Benefis will design and construct the 15th Avenue South extension for ±890 feet from its existing terminus at east of 29th Street South to 32nd Street South. If the City cannot acquire the ROW to accommodate construction of the entire segment at one time, Benefis will design and construct the western ±490 foot segment of 15th Avenue South adjacent to the Great Falls Clinic Surgery Center and the proposed Benefis Cascade Ridge Senior Housing project and escrow \$190,000.00 for future improvements of the ±400 foot eastern segment as such time as the City is able to acquire the ROW.

Benefis will be reimbursed by the Great Falls Clinic for 50% of the cost of the ±490 foot western segment of roadway abutting the existing Great Falls Clinic Surgery Center per the Annexation and Improvement Agreement for First Addition to Great Falls Clinic Addition, Amended Plat of Blocks 1 and 3, date March 2, 2004. Benefis will be reimbursed for 50% of the cost of the ±400 foot eastern segment of roadway from the owners of Mark 21A, Section 17, Township 20 North, Range 4 East, Cascade County, Montana at such time said Mark 21A is annexed into the City.

The existing City water main (12-inch) shall be relocated as necessary, extended to the south of the Grandview at Benefis property and built to City standards. The City sewer main (8-inch) shall be extended to the south of property and built to City standards. The proposed PUD indicates multiple retention/detention basins to be provided on site. Detention Pond overflow will ultimately be piped to the existing 26th Street South storm drain. Any new storm drains that are constructed in existing public right-of-way will be publicly owned. New storm drains and laterals that are constructed within the boundaries of the PUD will be owned and maintained by the property owner.

The developer is required to meet all City code requirements for Landscape, Signage and Lighting for the proposed project; all will be subject to review by the Design Review Board.

Neighborhood Council Input: Grandview at Benefis gave two presentations to Neighborhood Council 5 and one to Neighborhood Council 6. The following is the feedback that has been received from these Councils:

- Employee/visitor on-street parking on or near 14th Avenue South and 25th/26th Streets South is congesting those streets.
- One access in and out of Grandview would be problematic in the case of an emergency—from a citizen who is a member of the Citizens Emergency Response Training.
- Increased traffic in the medical area has also increased use of streets in the Council 6 area which has some gravel roads and limited east/west through streets. Also the development will increase travel on County road 24th Avenue South, which is a substandard road.
- The potential closing of 11th Avenue South from 26th to 28th Streets South would further inhibit east/west travel and would confuse emergency room access.
- Some residents are counting on the east/west connection that would be created on 15th Avenue South, which does not exist currently.
- Several 32rd Street South residents have expressed concerns with dust/erosion controls during construction and storm drainage issues on the east side of the development adjacent to Mountainview Addition residences.

Rezoning of subject property will enhance health, safety and welfare through application of City Codes and provision of municipal services.

Section 76-2-304 Montana Code Annotated lists criteria and guidelines, which must be considered in conjunction with establishing municipal zoning on land:

- a) is designed in accordance with the growth policy (comprehensive plan);
- b) is designed to lessen congestion in the streets;
- c) will secure safety from fire, panic or other dangers;
- d) will promote health and the general welfare;
- e) will provide adequate light and air;
- f) will prevent overcrowding of land;
- g) will avoid undue concentration of population;
- h) will facilitate the adequate provision of transportation, water, sewerage, schools, parks and other public requirements;
- i) gives reasonable consideration to the character of the district;
- j) gives reasonable consideration to the peculiar suitability of the property for particular uses;
- k) will conserve the value of buildings; and
- l) will encourage the most appropriate use of land throughout the municipality.

Applicable policy statements include “residential land uses should be planned and located so that they do not result in adverse impacts upon one another.” Therefore, staff concludes the above-cited criteria are substantially met.

The proposed PUD is compatible with the 2005 Growth Policy, as it advances specific Goals, Policies, and Action Strategies contained within the related plan elements, and is also in line with the general themes and principles found in the document. Plan elements related to the proposed PUD include Land Use, Housing, Economic Development and Transportation. Specifically, the proposed PUD provides a variety of housing types, provides an environment that allows the elderly to remain independent, and finally the proposed PUD expands the medical industry in Great Falls, an industry identified for future growth.

The proposed PUD is compatible with the vision of the Medical District Master Plan and many of the Goals, Objectives, and Implementation initiatives contained within the Plan. Specifically, the proposed PUD improves vacant land within the district, provides a variety of housing types and establishes a mix of uses.

Concurrences: Representatives from the City’s Public Works and Fire Departments have been involved throughout the review and approval process for this project.

Fiscal Impact: While the project is tax-exempt and not subject to paying property taxes, it will benefit the community in terms of desirable new development, employment and additional services, all consistent with the intent of the Medical District Master Plan.

Alternatives: The City Commission could deny of Ordinance 3074.

Attachments/Exhibits:

- Exhibit A: Vicinity/Zoning Map
- Exhibit B: Ordinance 3074
- Exhibit C: Reduced copy PUD Site Plan
- Exhibit D: Medical District Master Plan
- Exhibit E: Development Agreement with attachment

Cc: Jim Rearden, Public Works Director
Dave Dobbs, City Engineer
Patty Cadwell, Neighborhood and Youth Council Coordinator
John Juras, TD&H Engineering, 1200 25th Street South, Great Falls, MT 59405
Dave McGill, SFCS Inc., 305 South Jefferson Street, Roanoke, Virginia 24011-2003
Dawn Willey, Benefis Health System, 2621 15th Ave. South Great Falls, MT 59405

ORDINANCE 3074

AN ORDINANCE ASSIGNING A ZONING CLASSIFICATION OF PUD PLANNED UNIT DEVELOPMENT DISTRICT TO LOTS 1A1 AND 1B2, MOUNT OLIVET ADDITION, SECTION 17, TOWNSHIP 20 NORTH, RANGE 4 EAST, P.M.M., CASCADE COUNTY, MONTANA, TO BE KNOWN AS THE GRANDVIEW AT BENEFIS

* * * * *

WHEREAS, Lots 1A1 and 1B2, Mount Olivet Addition, Section 17, Township 20 North, Range 4 East, P.M.M., Cascade County, Montana, was annexed to the City of Great Falls on May 15, 2007; and,

WHEREAS, at the time of annexation, the City of Great Falls assigned a zoning classification of PLI Public land and institutional district classification to said Lots 1A1 and 1B2, Mount Olivet Addition; and,

WHEREAS, Benefis Health System., has petitioned the City of Great Falls to rezone said Lots 1A1 and 1B2, Mount Olivet Addition, to PUD Planned unit development district classification; and,

WHEREAS, notice of assigning said zoning classification to said Lots 1A1 and 1B2, Mount Olivet Addition, was published in the Great Falls Tribune advising that a public hearing on this zoning designation would be held on the 3rd day of May, 2011, before final passage of said Ordinance herein; and,

WHEREAS, following said public hearing, it was found and decided that the said rezoning designation be made.

NOW THEREFORE, BE IT ORDAINED BY THE COMMISSION OF THE CITY OF GREAT FALLS, STATE OF MONTANA:

Section 1. It is determined that the herein requested zoning designation will meet the criteria and guidelines cited in Section 76-2-304 Montana Code Annotated, and Section 17.16.40.030 of the Unified Land Development Code of the City of Great Falls.

Section 2. That the zoning classification of said Lots 1A1 and 1B2, Mount Olivet Addition, be designated as PUD Planned unit development district, subject to the PUD submittal dated February 9, 2011, kept at the Planning and Community Development Department of the City of Great Falls and by this reference made a part hereof.

Section 3. This ordinance shall be in full force and effect thirty (30) days after its passage and adoption by the City Commission or upon filing in the office of the Cascade County Clerk and Recorder the amended plat of the Amended Plat of Lot 1A1 and 1B2, Mount Olivet Addition, Section 17, Township 20 North, Range 4 East, P.M.M., Cascade County, Montana, whichever event shall occur later.

APPROVED by the City Commission on first reading April 5, 2011.

PASSED, APPROVED AND ADOPTED by the City Commission of the City of Great Falls, Montana, on second reading May 3, 2011.

Michael J. Winters, Mayor

ATTEST:

Lisa Kunz, City Clerk

(CITY SEAL)

APPROVED FOR LEGAL CONTENT:

James W. Santoro, City Attorney

State of Montana)
County of Cascade : ss
City of Great Falls)

I, Lisa Kunz, City Clerk of the City of Great Falls, Montana, do certify that I did post as required by law and as prescribed and directed by the City Commission, Ordinance 3074 in three conspicuous places within the limits of said City to-wit:

On the Bulletin Board, first floor, Civic Center Building;
On the Bulletin Board, first floor, Cascade County Court House;
On the Bulletin Board, Great Falls Public Library

Lisa Kunz, City Clerk

(CITY SEAL)

VICINITY/ZONING MAP

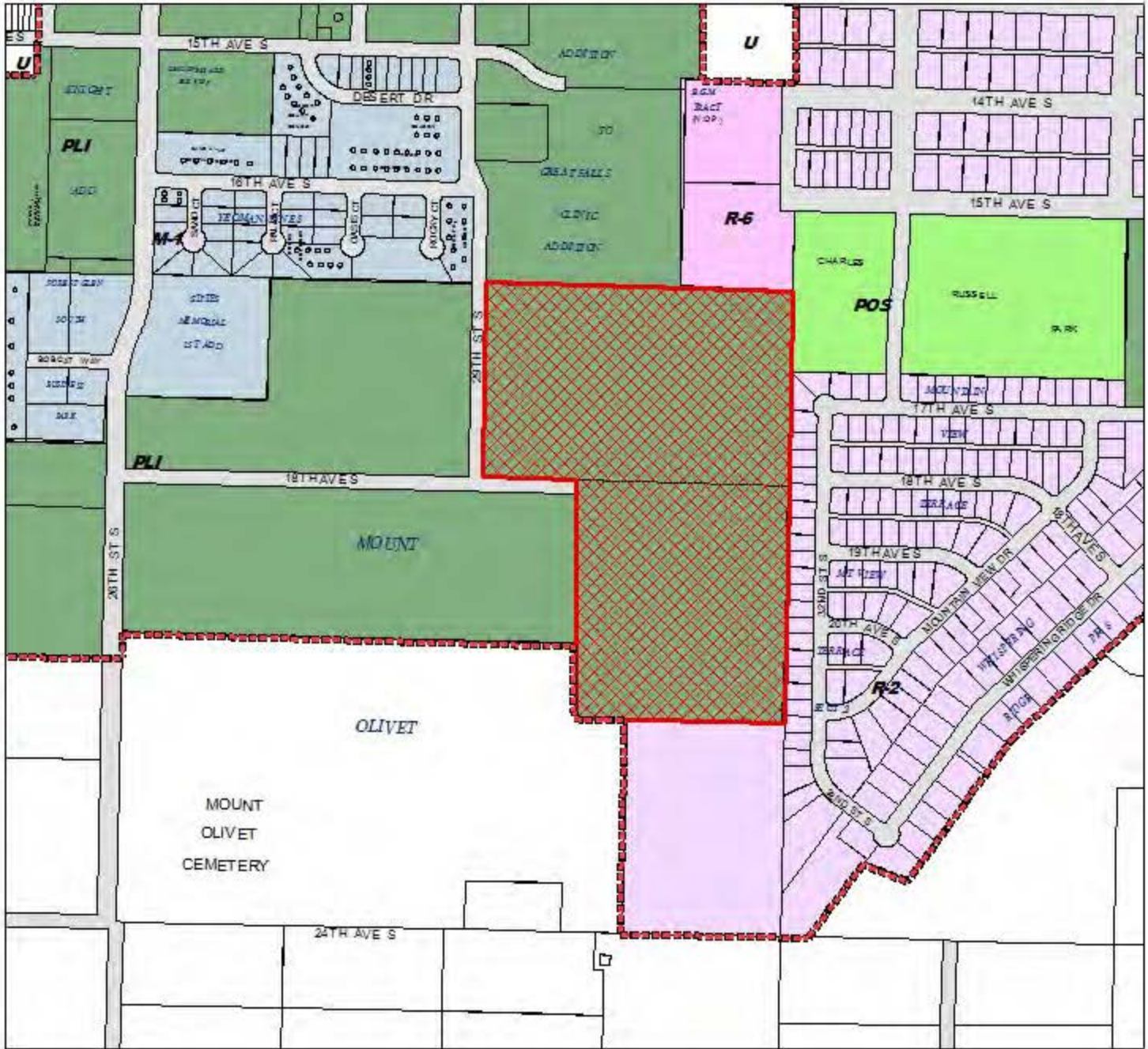

 Grandview at Benefits	 I-1 Light industrial	 R-10 Mobile home park
Zoning	 I-2 Heavy industrial	 R-2 Single-family medium density
 AI Airport Industrial	 M-1 Mixed-use district	 R-3 Single-family high density
 C-1 Neighborhood commercial	 M-2 Mixed-use transitional	 R-5 Multi-family medium density
 C-2 General commercial	 PLI Public lands institutional	 R-6 Multi-family high density
 C-3 Highway commercial	 POS Park Open Space	 R-9 Mixed residential
 C-4 Central business core	 PUD Planned unit development	 Unincorporated
 C-5 Central business periphery	 R-1 Single-family suburban	

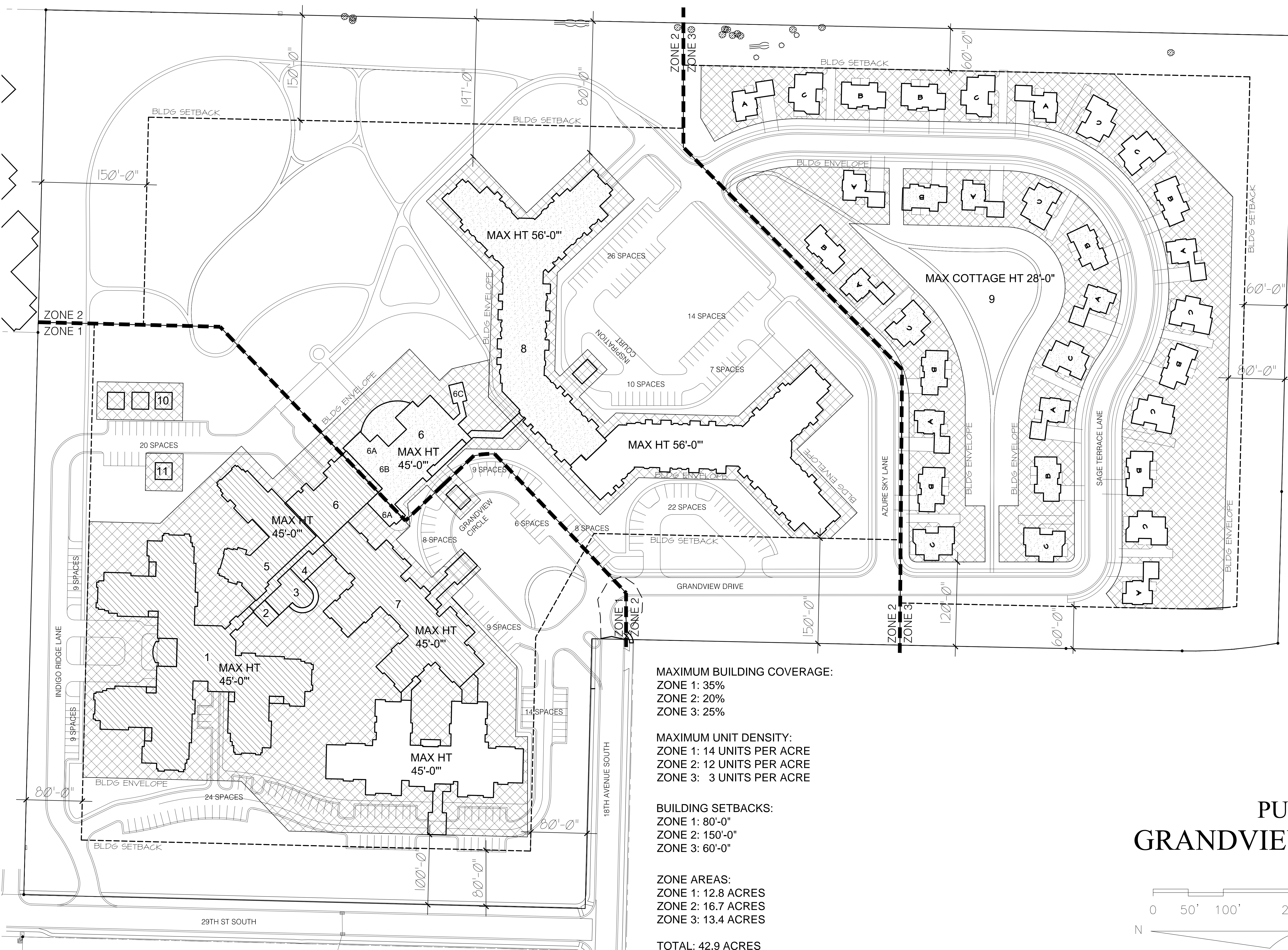

- BUILDING USES**
1. HEALTH CARE
 2. HEALTH CARE CLINIC
 3. THERAPY
 4. ADMIN
 5. MEMORY SUPPORT
 6. COMMONS
 - A. RESTAURANT
 - B. TAVERN
 - C. WORSHIP FACILITY
 7. ASSISTED LIVING
 8. INDEPENDENT LIVING
 9. COTTAGES
 10. WAREHOUSE
 11. VEHICLE REPAIR

- BUILDING ENVELOPE
- PHASE 1
- PHASE 2
- FUTURE PHASE

NOTES:
 1. BUILDING FOOTPRINTS ARE CONCEPTUAL & SUBJECT TO CHANGE

MAXIMUM BUILDING COVERAGE:
 ZONE 1: 35%
 ZONE 2: 20%
 ZONE 3: 25%

MAXIMUM UNIT DENSITY:
 ZONE 1: 14 UNITS PER ACRE
 ZONE 2: 12 UNITS PER ACRE
 ZONE 3: 3 UNITS PER ACRE

BUILDING SETBACKS:
 ZONE 1: 80'-0"
 ZONE 2: 150'-0"
 ZONE 3: 60'-0"

ZONE AREAS:
 ZONE 1: 12.8 ACRES
 ZONE 2: 16.7 ACRES
 ZONE 3: 13.4 ACRES

TOTAL: 42.9 ACRES

PUD DENSITY PLAN GRANDVIEW AT BENEFIS

02/08/11
 COMM. NO. 9111.03

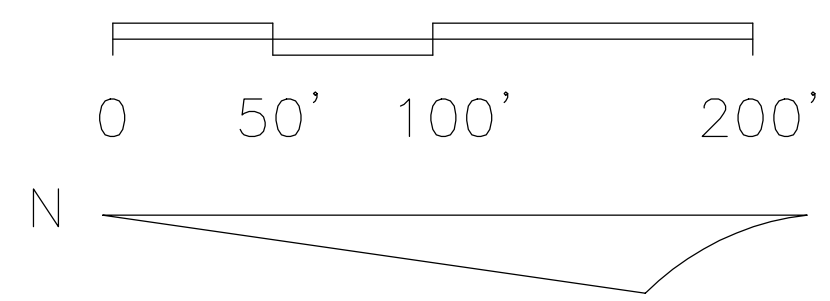

SFCs Architecture
 Engineering
 Planning
 Interiors
 SFCs Inc. • 305 South Jefferson Street
 Roanoke, Virginia 24011.2003
 540.344.6664 • Fax 540.343.6925
 www.sfcs.com

FRAMEWORK MASTER PLAN

EXISTING AND PROPOSED LAND USES

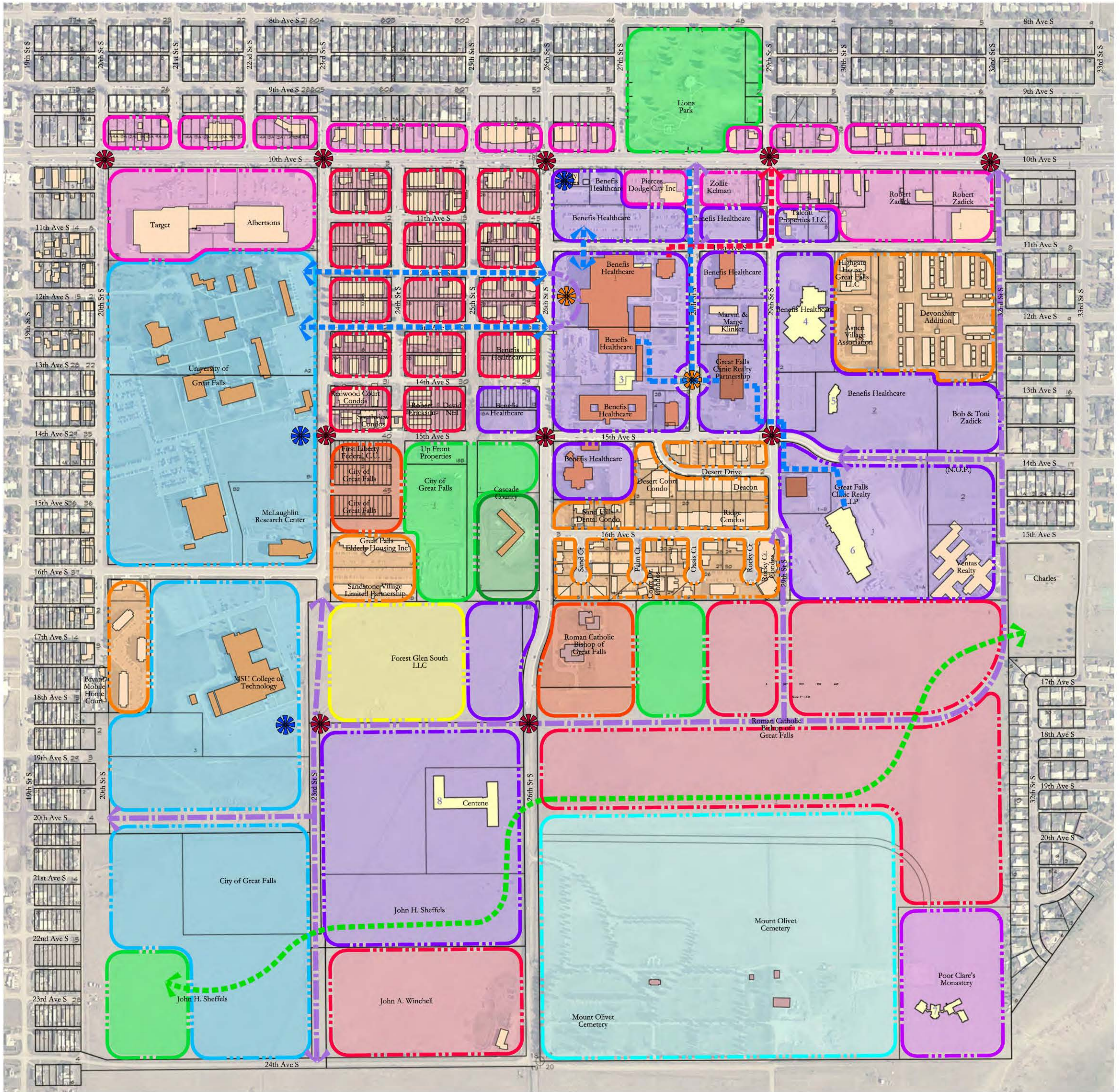

Legend

- | | | | |
|-----------------------|---------------------------|--------------------------------|--|
| Assisted Living | Institutional | Technology & Education | Proposed Street Extension or Improvement |
| Cemetery | Medical | Proposed Bus Route | Public Plaza or Community Space |
| Roman Catholic Church | Multi-Family Residential | Proposed Trail | Architectural or Sculptural Focal Point |
| Commercial | Single Family Residential | Proposed Bike Route | Proposed Signature Intersection |
| Mixed Use | Park | Proposed Emergency Route | Entrance to Building or Parking Lot |
| | | Proposed Pedestrian Connection | |



Great Falls Medical District • Master Plan • Great Falls, Montana

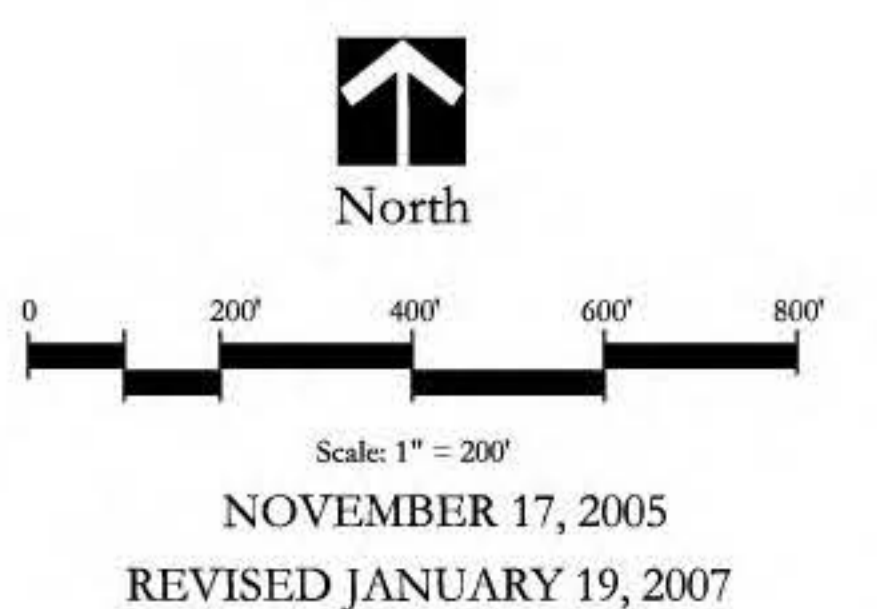
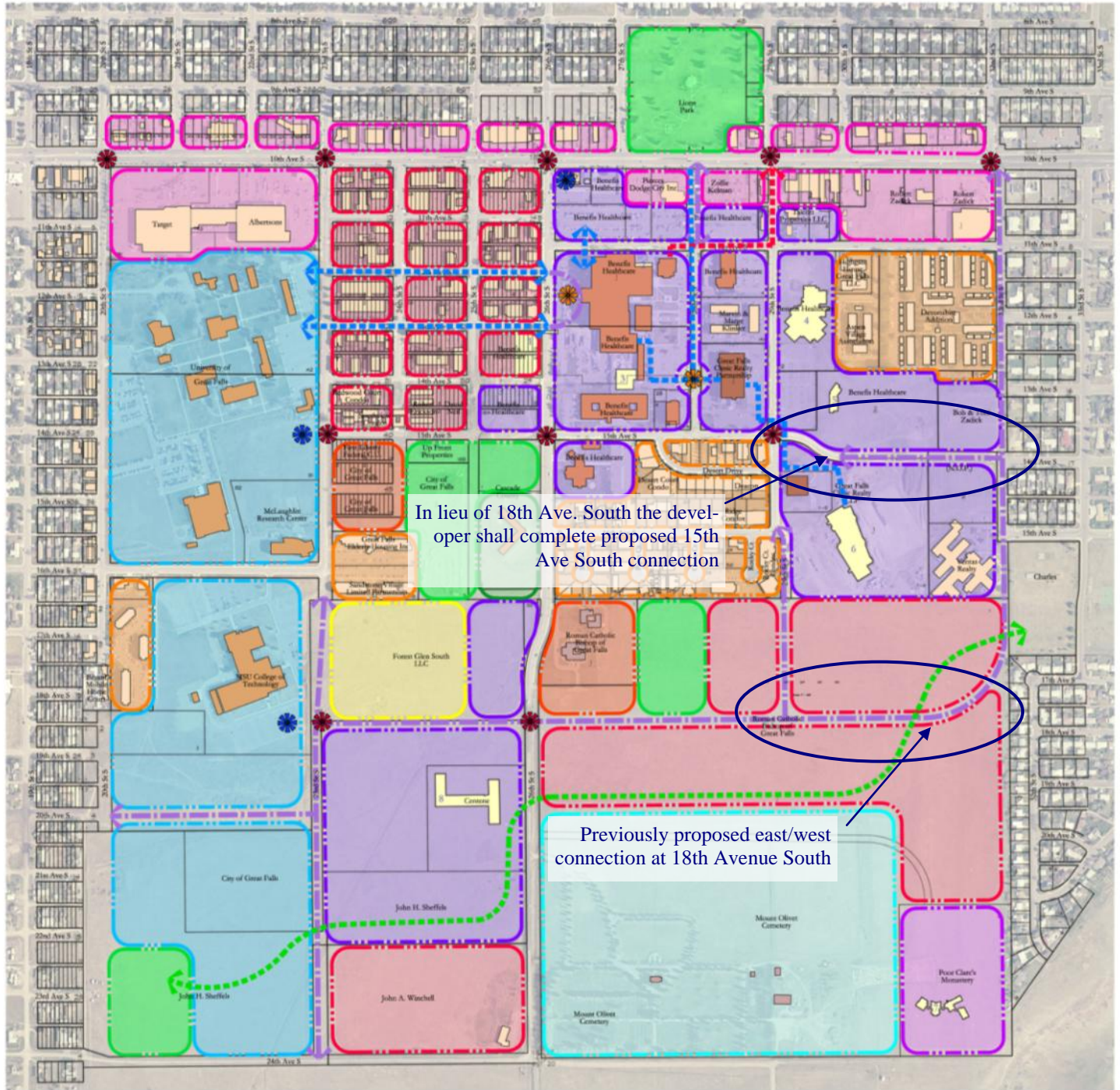

Exhibit D: Medical District Master Plan



In lieu of 18th Ave. South the developer shall complete proposed 15th Ave South connection

Previously proposed east/west connection at 18th Avenue South

Legend

- | | | | |
|-----------------------|---------------------------|--------------------------------|--|
| Assisted Living | Institutional | Technology & Education | Proposed Street Extension or Improvement |
| Cemetery | Medical | Proposed Bus Route | Public Plaza or Community Space |
| Roman Catholic Church | Multi-Family Residential | Proposed Trail | Architectural or Sculptural Focal Point |
| Commercial | Single Family Residential | Proposed Bike Route | Proposed Signature Intersection |
| Mixed Use | Park | Proposed Emergency Route | Entrance to Building or Parking Lot |
| | | Proposed Pedestrian Connection | |



Great Falls Medical District • Master Plan • Great Falls, Montana



EXHIBIT E
DEVELOPER AGREEMENT
FOR
GRANDVIEW AT BENEFIS PUD
IN SECTION 17,
TOWNSHIP 20 NORTH, RANGE 4 EAST,
CASCADE COUNTY, MONTANA

1. PREFACE

The following is a binding Agreement dated this _____ day of _____, 2011, between BENEFIS HEALTH SYSTEM hereinafter referred to as “Owner,” and the CITY OF GREAT FALLS, MONTANA, a municipal corporation of the State of Montana, hereinafter referred to as “City,” regarding the conditions of approval for assigning PUD zoning to the ±42.9-acre GRANDVIEW AT BENEFIS project, comprised of Lot 1A1 and Lot 1B2 Mount Olivet Addition, Section 17, Township 20 North, Range 4 East, Cascade County, Montana, hereinafter referred to as the “Project”.

2. PRIOR AND CURRENT ACTIONS

- A. The Planning Advisory Board, acting as the Zoning Commission, recommended the City Commission approve a rezoning of the Project from PLI (Public Lands and Institutional) to PUD (Planned Unit Development) subject to fourteen (14) conditions of approval on February 22, 2011.
- B. City Commission will hold a public hearing to approve or deny the rezoning to PUD on May 3, 2011.

3. SUPPORTING DOCUMENTS

- A. Amended Plat of Lot 1A1 and Lot 1B2, Mount Olivet Addition, prepared by Thomas Dean & Hoskins (TD&H), and filed of record in the Clerk and Recorder’s Office of Cascade County, Montana.
- B. Final engineering drawings, specifications and cost estimates prepared by TD&H Engineers, consisting of documents for sanitary sewer mains, water mains, storm drainage improvements, paving, sidewalks and curb and gutter, including final engineering drawings, specifications and cost estimates for the extension of 15th Avenue South from its current terminus east of 29th Street South, easterly to the western existing boundary of 32nd Street South. Said drawings and specifications are on file in the City Engineer’s office.

- C. Subdivision Plat of First Addition to Great Falls Clinic Addition.
- D. Amended Plat of Blocks 1 and 3, First Addition to Great Falls Clinic Addition.
- E. Subdivision Plat of B.G.M. Tracts.

4. AMENDMENTS

Minor changes to engineering plans and specifications may be made as are deemed appropriate and necessary by City's Engineer and City's Public Works Department and which do not materially affect the Project, may be made as follows:

- A. The proposed revision will be submitted to City's Public Works Department for review and, if approved, the City Engineer or Public Works Director will sign and adequately annotate the change.
- B. The annotated revision becomes a part of this Agreement upon City's Public Works Department approval.
- C. Changes during construction shall be made by change order approved by City's Public Works Department.
- D. "As Built" reproducible drawings shall be supplied to City's Engineer upon completion of the construction.
- E. All amendments to this Agreement, except as allowable above in this section, shall be in writing and approved by City and Owner.

5. UNFORESEEN POTENTIALITIES

It is mutually recognized, understood and agreed by City and Owner that subsequent to the time this agreement was entered into, events may occur and actions may be taken that were unforeseen by either party or both parties hereto. It is therefore agreed that the parties may by mutual subsequent agreement modify the terms, conditions and covenants of this Agreement.

6. FEES AND CHARGES

- A. Owner has paid fees totaling \$700.00 for the processing the rezoning application for the Project.
- B. Owner or its successors or assigns shall reimburse City for its expenses incurred in testing and acceptance of public utilities to serve Project at the rates charged by City for said work at the time performed.
- C. Water tapping, water connection, sewer service tapping, and sewer connection fees will be assessed at the time of installation.
- D. The absence of any fee from this agreement lawfully charged by the City in connection with construction activity associated with Project shall not constitute a waiver by the City.

7. ERRORS AND OMISSIONS

The Amended Plat of Mount Olivet Addition containing Grandview at Benefis shall incorporate corrections of any errors or omissions noted by staff.

8. MEDICAL DISTRICT MASTER PLAN

The Medical District Master Plan anticipated that 18th Avenue South would be extended east (through the Project) to connect with 32nd Street South and that 15th Avenue South, north of the Project, would be extended east to connect with 32nd Street South. These roadway

connections were determined needed to maintain adequate traffic flow within and through the Medical District. Owner agrees, in lieu of the 18th Avenue South connection through the Project, to construct or fund construction of the more critical 15th Avenue South roadway connection between its current terminus east of 29th Street South, ±890 feet easterly to 32nd Street South, in cooperation with City, subject to the terms of this agreement.

9. DEDICATION AND CONSTRUCTION OF 15th AVE SOUTH THROUGH FIRST ADDITION TO GREAT FALLS CLINIC ADDITION (±490 LINEAR FEET)

- A. Owner agrees to dedicate required public right-of-way ±490 linear feet across the southernmost 42 feet of Lot 1, Block 2, First Addition to Great Falls Clinic Addition hereinafter referred to as “Right-of-Way A” pursuant to the existing Annexation Agreement for Lot 1, Block 2, First Addition to Great Falls Clinic Addition, dated March 15, 2005. City agrees to obtain ±490 feet of required right-of-way dedication along the northernmost 18 feet of Lot 1A, Block 1, First Addition to Great Falls Clinic Addition hereinafter referred to as “Right-of-Way B” pursuant to the existing Annexation and Improvement Agreement for First Addition to Great Falls Clinic Addition, Amended Plat of Blocks 1 and 3, date March 2, 2004. (See Attachment A to this Agreement for depiction of rights-of-way and property/roadway dimensions)
- B. Owner agrees to pay for and have prepared Amended Plats for Lot 1, Block 2 and Lot 1A, Block 1, First Addition to Great Falls Clinic Addition, dedicating the rights-of-way described in 9.A above.
- C. Owner agrees to complete within two (2) years of the date of this Agreement or before any Certificate of Occupancy is issued by the City for any phase of the Project (whichever is sooner) the installation of the required improvements to the above described segment of 15th Avenue South including water main, fire hydrant, sanitary sewer main and storm sewer main improvements, conduit for public roadway lighting facilities, curb, gutter, pavement, sidewalk, traffic control and signage. Furthermore, Owner shall be entitled from the owners of Right-of-Way B, to 50% of the costs of said improvements (water main, fire hydrant, sanitary sewer main and storm sewer main improvements, conduit for public roadway lighting facilities, curb, gutter, pavement, sidewalk, traffic control and signage) abutting said property referenced hereinabove pursuant to the existing Annexation and Improvement Agreement for First Addition to Great Falls Clinic Addition, Amended Plat of Blocks 1 and 3, date March 2, 2004.
- D. Owner shall provide City with its actual cost of the installation of the above described improvements (water main, fire hydrant, sanitary sewer main and storm sewer main improvements, conduit for public roadway lighting facilities, curb, gutter, pavement, sidewalk, traffic control and signage) upon completion of those improvements and acceptance thereof by City. City shall then request reimbursement from the owners of Right-of-Way B for 50% of that cost. In the event of Owner’s failure to provide City with said cost data, City shall not be obliged to undertake collection of the reimbursement provided for herein, and the responsibility for collection thereof shall be that of Owner, its heirs, successors and assigns. Failure of Owner to provide City with said cost data for reimbursement as herein required shall in no way alter the obligation of any other party to make reimbursement as provided for herein, said failure affecting only City’s obligation to assist in collection thereof.

10. NEGOTIATE, DEDICATE AND CONSTRUCT 15th AVE SOUTH THROUGH B.G.M. TRACTS (±400 LINEAR FEET)

- A. City agrees to negotiate with the property owner of Block 2, B.G.M. Tracts to obtain dedication of 15th Avenue South along the northernmost 60 feet of said tract, easterly from the terminus of 15th Avenue South to the connection at the western boundary of 32nd Street South, consisting of ±400 feet hereinafter referred to as “Right-of-Way C.”
- B. Should the City acquire Right-of-Way C prior to construction of the improvements in Rights-of-Way A and B, the Owner agrees to the concurrent installation of improvements on Right-of-Way C (Block 2, B.G.M. Tracts) including water main, fire hydrant, sanitary sewer main and storm sewer main improvements, conduit for public roadway lighting facilities, curb, gutter, pavement, sidewalk, traffic control and signage.
- C. Should the City not acquire Right-of-Way C described above prior to construction of Rights-of-Way A and B, Owner shall escrow with the City the estimated cost to design and install the improvements for Right-of-Way C. The City will install the improvements when Right-of-Way C is secured in public ownership. The City’s engineering office estimates the cost of these improvements to be \$190,000.00. Owner hereby agrees to provide a certificate of deposit in the name of Owner and City, in the amount of \$190,000.00. At such time as the actual cost of the above referenced improvements are definitely determined, an amount equal to said costs shall be transferred from the above referenced account to City. Upon said transfer, any remaining balance in the above referenced account shall be released to Owner.
- D. The Owner shall be entitled to reimbursement for 50% of the costs of improvements for water main, fire hydrant, sanitary sewer main and storm sewer main improvements, conduit for public roadway lighting facilities, curb, gutter, pavement sidewalk, traffic control and signage, from the owners of Mark 21A, Section 17, Township 20 North, Range 4 East, Cascade County Montana, abutting said property (±400 linear feet) at such time said Mark 21A is annexed into the City.
- E. Owner shall provide City with actual cost of the installation of the above described improvements (water main, fire hydrant, sanitary sewer main and storm sewer main improvements, conduit for public roadway lighting facilities, curb, gutter, pavement, sidewalk, traffic control and signage) upon completion of those improvements and acceptance thereof by City. Upon annexation of Mark 21A (Zadick Property) City shall obtain reimbursement from those owners for 50% of that cost and transfer to Owner. In the event of Owner’s failure to provide City with said cost data, City shall not be obliged to undertake collection of the reimbursement provided for herein, and the responsibility for collection thereof shall be that of Owner, its heirs, successors and assigns. Failure of Owner to provide City with said cost data for reimbursement as herein required shall in no way alter the obligation of any other party to make reimbursement as provided for herein, said failure affecting only City’s obligation to assist in collection thereof.

11. FUTURE EASEMENTS AND DEDICATION OF 30th STREET SOUTH

Owner hereby agrees to provide existing and future easements and dedicated rights-of-way as required and install required sanitary sewer, water mains, drainage improvements, street

paving, sidewalk and curb and gutter along that portion of 30th Street South within the western boundary of the Project when deemed necessary by City based upon additional incorporated development in the vicinity utilizing said infrastructure and roadway for access.

12. FUTURE STREET IMPROVEMENTS OF 30th STREET SOUTH

- A. Owner shall pay the full cost of the equivalent twelve-inch (12") water main and eight-inch (8") sewer main to be installed in the extension of 30th Street South to the property boundary. At such time the actual cost of the above referenced improvements and remaining water main is definitely determined, an amount equal to said costs shall be paid to the City.
- B. Owner hereby agrees to pay proportionate share of future street improvements to 30th Street South including paving, sidewalks and curb and gutter and further agrees to pay proportionate share of any future storm drainage improvements within 30th Street South, at such time as City deems necessary.
- C. Additionally, to accommodate the long term growth plan that City foresees, Owner agrees to install required over-sizing (water main) improvement, instead of the standard City required improvements in the portion of 30th Street South abutting Project. City agrees to reimburse Owner for 50% of the over-sizing cost of improvements installed in 30th Street South within (30) days of its acceptance of the installations and appropriate billing, including provisions of adequate information and documentation supporting said costs.
- D. Owner shall prepare all plans and specifications for improvements under this section in accordance with standards of the City, and with the review and approval of the City Engineer and the City Public Works Department.

13. PUBLIC IMPROVEMENTS

Owner agrees to complete within two (2) years of the date of this Agreement, the installation of the sanitary sewer and water improvements, drainage improvements, street paving, sidewalks and curb and gutter to serve Project, according to plans referenced in Paragraph 3.B. above and filed in the City Engineer's Office and in accordance with standards of City. When deemed appropriate and necessary by The City Engineer and City Public Works Department, the completion date of said public improvements may be extended as approved by the City. The proposed revision will be submitted to City Engineer and City Public Works Department for review and, if approved, the City Engineer or Public Works Director will sign and adequately annotate the change.

- A. Owner hereby agrees to prepare and provide final engineering drawings and specification for the 16 foot wide off-street emergency access route that shall be approved by the City Engineer's Office.
- B. Owner hereby agrees to prepare and provide final engineering drawings and specification for the on-site utilities that shall be approved by the City Engineer's Office.
- C. Owner hereby agrees to provide and obtain final engineering drawings and specification for the eastern terminus of 18th Avenue South and mini-round-a-bout or similar traffic device.

14. SOIL AND/OR GROUNDWATER CONDITIONS

Owner hereby agrees to indemnify and hold the City, its employees, agents and assigns harmless for and against all damages, claims, attorney fees, judgments, demands and/or liabilities that may, arise from, be attributable to or be sustained as a result of adverse soil and/or groundwater conditions associated with Project.

Owner hereby agrees to provide a geotechnical investigation and report prepared by a Professional Engineer (and indemnifying the City) with recommended building foundation design, which shall be submitted to the Planning and Community Development Department for review and approval.

15. RESTRICTIONS ON BUILDING PERMITS AND OCCUPANCY

Building permits shall not be issued until the contracts for installation of the public improvements have been executed. Owner acknowledges that City will not permit the occupancy of any residential structure until street improvements and water and sanitary sewer mains have been installed, tested and accepted by City, which acceptance will not be unreasonably withheld by City.

16. DESIGN REVIEW BOARD

Owner hereby agrees that development shall be in general accordance with the building elevations, site plan, landscape plan, signage and lighting plans within the PUD Submittal dated February 9, 2011. Further, the owner hereby agrees to submit all proposed drawings including architectural, landscape, signage and lighting plans as required for review and approval by the Design Review board prior to the issuance of building permits.

17. MAINTENANCE DISTRICTS

Owner hereby agrees to waive its right to protest the lawful creation by City of maintenance districts for any proper purpose including, but not limited to, fire hydrant and street maintenance and shall pay the proportionate share of the costs associated with said maintenance districts as they may be applied to lots in Project.

18. FUTURE STORM DRAINAGE FACILITIES

Owner hereby agrees to waive its right to protest any future area wide special improvement district for storm drainage facilities and further agrees to pay for proportionate share of any future storm drainage improvements that service Project that may be installed with or without an area wide special improvement district. The term "area wide" as used herein, means any area larger than that covered by Project, which is a contributor to the drainage sub-basin of which Project is a part.

Owner hereby agrees to provide a Grading Plan, State Stormwater Discharges Associated with Construction Activities Permit, and Stormwater Management Plan, which shall be developed to City standards and shall be submitted to the City Engineers Office.

19. PUBLIC ROADWAY LIGHTING

Owner hereby agrees to waive its right to protest any future special lighting district for public roadway lighting facilities that service Project, and further agrees to pay for

proportionate share of the costs associated with roadway lighting which service Project that may be installed with or without a special lighting district.

20. SIDEWALKS

It is hereby agreed that the following exception to the strict adherence of Project requirements will be permitted: sidewalks serving and abutting any lot in Project shall be installed as a condition of final occupancy by the then lot owner within six (6) months (allowing for unfavorable weather conditions only) of occupancy. It is understood that the above provision regarding sidewalks shall not preclude City from exercising its authority provided by Chapter 12.28, Municipal Code of the City of Great Falls pertaining to sidewalks.

- A. Owner hereby agrees to provide a sidewalk and boulevard extension adjacent to 29th Street South for the entire length of the property that will be constructed to City standards and maintained according to City Code.
- B. Owner hereby agrees to provide a 20 foot easement to the City and construct and maintain a 10 foot bike/pedestrian access route from Charles Russell Park to 29th Street South.

21. WARRANTY, OWNERSHIP AND INSPECTION OF UTILITY AND STREET IMPROVEMENTS

- A. After the public utilities, drainage and street improvements described in Paragraph 3.B. hereof have been installed and accepted by City, the same shall be in all respects treated, owned and maintained as though the same had been constructed and installed by City. However, to the extent installed by Owner, Owner or its contractor shall guarantee said improvements against defective work and materials for a period of two (2) years from date of acceptance of the completed improvements by City.
- B. Installation of the public utilities and street improvements described in this agreement hereof, shall be subject to City's infrastructure inspection policy in place at the time of installation.

22. CITY ACCEPTANCE AND ZONING

In consideration of the foregoing, City hereby accepts and approves the amended plat and zoning of PUD Planned Unit Development

23. ADHERENCE TO SITE PLAN

Owner hereby agrees that development upon Lot 1A1 and Lot 1B2 Mount Olivet Addition, Section 17, Township 20 North, Range 4 East, Cascade County, Montana shall be substantially in accordance with the PUD document dated February 9, 2011 kept at the Planning and Community Development Department of the City of Great Falls and by this reference made a part hereof and applicable City Codes, and the terms and conditions contained in this Agreement.

24. BINDING EFFECT

The provisions, covenants and terms of this Agreement shall run with the land and bind the present owners, their devisees, heirs, successors, and assigns; and any and all parties

claiming by, through, or under them, shall be taken to agree and covenant with each of the parties to the Agreement, their devisees, heirs, successors and assigns, to conform to the provisions, covenants and terms of this Agreement.

IN WITNESS WHEREOF, the parties hereto have set their hands and seal the day, month and year first hereinabove written.

THE CITY OF GREAT FALLS, MONTANA
A Municipal Corporation of the State of Montana

Gregory T. Doyon, City Manager

ATTEST:

Lisa Kunz, City Clerk

(Seal of City)

APPROVED FOR LEGAL CONTENT:

James W. Santoro, City Attorney

BENEFIS HEALTH SYSTEMS

Terry Olinger, Chief Human Resources & System
Services Officer

State of Montana)

:ss.

County of Cascade)

On this _____ day of _____, in the year Two thousand and Eleven, before me, the undersigned, a Notary Public for the State of Montana, personally appeared Terry Olinger, known to me to the persons whose names are subscribed to the instrument within and acknowledged to me that they executed the same.

IN WITNESS WHEREOF, I have hereunto set my hand and affixed my Notarial Seal the day and year first above written.

Notary Public for the State of Montana

(NOTARIAL SEAL)

Notary Public for the State of Montana (Printed)
Residing at _____
My commission Expires _____, 20_____

**Developer Agreement
Grandview Benefis PUD
Attachment A**

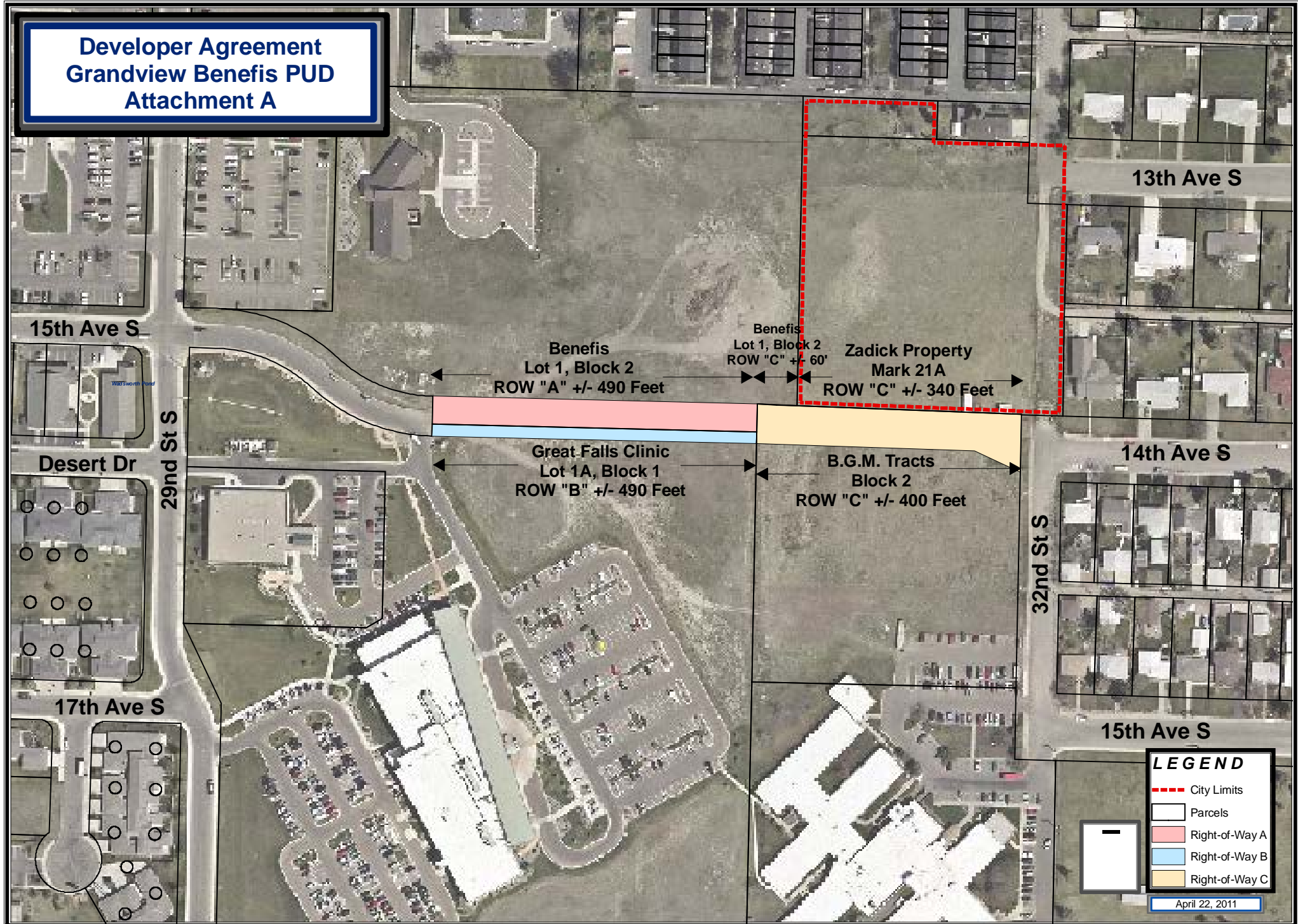



Item: Annual Action Plan Including Use of 2011/2012 CDBG & HOME Funds

From: Mike Haynes, AICP, Planning and Community Development Department Director

Initiated By: Wendy Thomas, AICP, Planning and Community Development Deputy Director

Presented By: Mike Haynes, AICP, Planning and Community Development Department Director

Action Requested: Adoption of the Annual Action Plan and authorization of its submittal to the U. S. Department of Housing and Urban Development.

Suggested Motion:

1. Commissioner moves:

“I move that the City Commission adopt the Annual Action Plan including the use of the 2011/2012 Community Development Block Grant funds and 2011/2012 HOME Program funds as recommended.”

2. Mayor calls for a second, discussion, inquiries from the public, and calls the vote.

Staff Recommendation: The Community Development Council and staff recommend the City Commission adopt the Annual Action Plan including the use of the 2011/2012 Community Development Block Grant (CDBG) funds and the use of the 2011/2012 HOME Investment Partnership Program funds, and authorize submittal to the U. S. Department of Housing and Urban Development (HUD).

Background: The Annual Action Plan portion of the Consolidated Plan includes the proposed use of CDBG and HOME funds for the upcoming fiscal year. The Consolidated Plan is a 5-year comprehensive planning strategy required by HUD.

CDBG and HOME Grant project applications were received in January, 2011. The Community Development Council reviewed the applications and made funding recommendations to the City Commission on March 15, 2011. Staff is recommending that un-programmed funds be allocated to Affordable Housing to grant the full funding request by Neighborworks. A 30-day comment period, March 30, 2011 through April 28, 2011, was established to receive citizen views on:

- The proposed Annual Action Plan,

- The proposed use of 2011/2012 CDBG and HOME funds; and,
- Program performance and policies.

A copy of the proposed Annual Action Plan was available for review in the City CDBG/HOME & Neighborhood Council office, the Great Falls Public Library, and the City of Great Falls web page. In addition, the City Commission held a public hearing on April 19, 2011 to receive input.

At the conclusion of the 30-day comment period, the City Commission must adopt as recommended, or amend and adopt, the final Annual Action Plan for submittal to HUD in order for the City to continue to receive CDBG and HOME program funds. HUD must receive the Plan on or before May 15, 2011. The final Annual Action Plan is on file in the City Clerk's office.

Concurrences: The Community Development Council reviewed the applications and made funding recommendations to the City Commission on March 15, 2011.

Fiscal Impact: The City of Great Falls is currently expecting to receive \$845,880 of Community Development Block Grant funds, and \$385,454 of HOME funds from HUD in the coming year.

Alternatives: The City Commission may choose to approve the Annual Action Plan as presented or amend the plan.

Attachments/Exhibits:

Proposed Funding List
Public Comments

**2011/2012 PROPOSED USE OF FEDERAL GRANT FUNDS
COMMUNITY DEVELOPMENT BLOCK GRANT
May 3, 2011**

Affordable Housing

	<u>Requested</u>	<u>Proposed</u>
<p>GREAT FALLS CITY PLANNING & COMMUNITY DEVELOPMENT – REHABILITATION SPECIALIST Provision of rehab counseling, loan processing, inspections and construction monitoring for all CDBG-funded City revolving loan housing programs for low income people</p>	\$63,600	\$63,600
<p>GREAT FALLS CITY PLANNING & COMMUNITY DEVELOPMENT – WATER & SEWER LOAN PROGRAM Funds to expand citywide no interest/low interest loan program for low income homeowners and property owners who provide rental units which remain affordable to low income households to construct or replace water and sewer lines</p>	\$60,000	\$43,171
<p>NEIGHBORHOOD HOUSING SERVICES, INC. Revolving loan fund to provide down payment assistance, new construction, purchase and rehabilitation of houses and other activities addressing neighborhood revitalization activities in their CBDO-designated neighborhoods</p>	\$150,000	\$107,778

Economic Development

<p>GREAT FALLS DEVELOPMENT AUTHORITY Expand revolving loan fund to provide gap financing to existing and start-up businesses to create new jobs for persons from low to moderate income households, agency located at 300 Central Avenue</p>	\$50,000	\$0
---	----------	-----

Public Facility Improvements

<p>UPPER & LOWER RIVER ROAD WATER & SEWER DISTRICT Phase 4 of multi-phase project to extend city water and sewer mains, project site 31st Avenue South between Upper River Road and 4th Street South and 32nd Avenue South between 3rd Street and 4th Street South</p>	\$332,000	\$332,000
--	-----------	-----------

Public Service Activities

	<u>Requested</u>	<u>Proposed</u>
<p>AREA VIII AGENCY ON AGING Purchase food for Meals on Wheels, a citywide home delivery meal program for seniors who are handicapped or unable to prepare meals</p>	\$20,000	\$20,000
<p>CASA-CAN CHILDREN’S ADVOCATE NETWORK Purchase laptop computer and volunteer training materials and provide continuing education and training conference expenses to expand volunteer program located at 415 2nd Avenue North which provides advocates for abused and neglected children in the legal system Fund laptop computer (\$1,200), volunteer training materials (\$700) and continuing education (\$500)</p>	\$5,300	\$2,400
<p>CASCADE COUNTY LAW CLINIC Purchase copier/scanner, desktop computer and laptop computer for agency which provides assistance in civil matters of family law to low income people, agency located at 401 3rd Avenue North Fund copier/scanner (\$4,450) and laptop computer (\$750)</p>	\$6,350	\$5,200
<p>CHILD CARE SOLUTIONS MONTANA Provide child care scholarships for low to moderate income families, agency located at 202 2nd Avenue South</p>	\$15,000	\$13,125
<p>FARM IN THE DELL MONTANA Purchase gardening supplies, tools and equipment to develop vocational programming in greenhouse work, gardening, compost production, farming and animal husbandry for low to moderate income developmentally disabled adults living in Great Falls</p>	\$5,036	\$5,036
<p>GREAT FALLS SENIOR CITIZENS CENTER Purchase food and equipment for on-site meal program for the elderly administered in facility located at 1004 Central Avenue All funding to go toward purchase of food</p>	\$10,000	\$10,000
<p>HANDS, INC. Provide child care scholarships for children from low income families, program offered at all Great Falls elementary schools</p>	\$30,000	\$15,036

	<u>Requested</u>	<u>Proposed</u>
<p>PARIS GIBSON SQUARE Purchase two potter's wheels, adaptive equipment and art class supplies to provide art class programming at museum located at 1400 1st Avenue North Fund VSA Program supplies (\$2,100), \$1,000 in adaptive equipment and 1 pottery wheel (\$1,050) which will be restricted for 1 year to use by people with LMI only</p>	\$8,400	\$4,150
<p>QUALITY LIFE CONCEPTS, INC. Purchase equipment (scanner software, shredder, utility trailer, riding lawn mower, two push mowers, leaf blower) to expand work services program for developmentally disabled adults located at 215 Smelter Avenue Northeast</p>	\$16,180	\$16,180
<p>RURAL DYNAMICS, INC. Provide credit counseling service scholarships for low to moderate income people, agency located at 2022 Central Avenue</p>	\$15,000	\$15,000
<p>YOUNG PARENTS EDUCATION CENTER Provide day care scholarships and emergency housing scholarships for very low to low income teen or young adult parents completing high school or GED programs, programs located at alternative high school at 2400 Central Avenue</p>	\$20,000	\$20,000
<i>Administration</i>		
<p>CDBG PROGRAM ADMINISTRATION General oversight, promotion, financial accountability, monitoring, reporting, and coordination of the CDBG program including activities to further fair housing and the Continuum of Care for Homelessness</p>	\$201,400	\$168,169
TOTAL CDBG FUNDING REQUESTED	\$1,007,000	
UNPROGRAMMED FUNDING		\$42,222
TOTAL CDBG FUNDING RECOMMENDATION		\$840,845
TOTAL ANTICIPATED CDBG GRANT		\$840,845
TOTAL AVAILABLE CDBG GRANT FUNDS		\$840,845

**2011/2012 PROPOSED USE OF FEDERAL GRANT FUNDS
HOME INVESTMENT PARTNERSHIP PROGRAM**

	<u>Requested</u>	<u>Proposed</u>
NEIGHBORHOOD HOUSING SERVICES, INC. Owners in Partnership XIX—construct and rehabilitate single family houses and provide down payment and closing cost assistance for low income home buyers on citywide basis	\$395,000	\$346,990
HOME PROGRAM ADMINISTRATION General oversight, management, promotion, financial accountability, monitoring and coordination of the HOME program	\$43,800	\$38,545
TOTAL HOME FUNDING REQUESTED	\$438,800	
TOTAL HOME FUNDING RECOMMENDATION		\$385,454
TOTAL ANTICIPATED HOME GRANT		\$385,454
TOTAL AVAILABLE HOME FUNDS		\$385,454

Community Proposed Plan Public Hearing Summary
City Commission Meeting
April 19, 2011

A public hearing was held as part of the regular City Commission meeting on April 19, 2011, at 7 p.m. in the Commission Chambers at the Civic Center. The hearing was held to provide an opportunity for citizens to advise the City Commission on their opinions regarding the proposed 2011/2012 Annual Action Plan, the proposed use of Community Development Block Grant (CDBG) and HOME Investment Partnership Program (HOME) funds for the upcoming year and on the performance of the CDBG and HOME grant programs in administration, distribution and implementation of federal funds.

Michael Haynes, director of Planning and Community Development (PCD), advised the City Commission the final federal government budget was recently approved and indications are the City can anticipate a 16.5% reduction in CDBG funding and at least a 12% reduction in HOME funding compared to the amounts received in 2010/2011. There will also be additional reductions in funding levels in future years or programs may be entirely eliminated. The PCD will be carefully watching these developments at the federal level.

One of the funding recommendations provided by the Community Development Council (CDC) was based on a possible 20% reduction in CDBG funding compared to last year. On April 18, 2011, the PCD provided the City Commission and the City Clerk with revised proposed project amounts based on the best information available. Further revisions will likely be required before final action is undertaken on the proposed Action Plan on May 3 as the PCD gets further information from the federal government.

The following listing is a summary of the comments which were expressed in the public hearing.

Opponents: None

Proponents:

Nancy Wilson, Meals on Wheels. Ms. Wilson reported Meals on Wheels has depended on CDBG funding to make sure senior citizens in Great Falls will always have the meals they need. She noted the agency provided 318 meals today and there is no waiting list for this service, partially due to receiving CDBG funding. Meals on Wheels requested a reduced amount of CDBG funds this year (\$20,000) and thinks they can ask others in the community for support. Ms. Wilson encouraged adoption of the 2011/2012 Plan in its entirety, noting it included housing for low income seniors.

Brett Doney, Great Falls Development Authority (GFDA). Mr. Doney commended PCD for improvements made in the CDBG process this year and thanked them for looking at new ways the City can use CDBG funds to help the most needy people in the city. Mr. Doney reported the Montana Department of Labor released March employment numbers today

which reflected a rising work force of 466 jobs being added in Cascade County in March. He noted the labor force in Cascade County is 41,340 which is the largest labor force in the history of Cascade County. Mr. Doney indicated the number of jobs are increasing but the unemployment rate remains very high at 6.9% which translates to 2,868 people looking for work in Cascade County last month, Mr. Doney related how this year the GFDA advised the PCD that the highest economic need was for technical assistance for the hundreds of entrepreneurs they are working with to create more jobs. He noted that in the past two years the GFDA proposals were not presented to the CDC because of various reasons and they will work with the CPD to make sure the future proposals are presented to the CDC. Mr. Doney encouraged the City Commission to encourage PCD to have the CDC meet at least once per quarter rather than one time a year as economic development changes occur throughout the year.

John Stephenson-Love, Upper & Lower River Road Water & Sewer District (District). Mr. Stephenson-Love described how the District is slated to get \$332,000 in CDBG grant funds for Phase 4 of this project. He described the completed and proposed timeline for Phase 4, including that they have created the district and an election is scheduled for June 21. If they have a successful bond election they will call for bids and proceed to get the area annexed into the city limits. The District hopes to have Phase 4 completed by mid-Fall. 393 dwelling units will be served with the completion of Phase 4. There are a total of 447 units in the District. Mr. Stephenson-Love noted that after Phase 4 is done 87.9% of the residential units will be hooked up to city water and sewer and annexed into the city. He described the total estimated population of the District as being 1,118 people and calculated that 983 residents (87.9%) would be added to the population of Great Falls when the project is done.

Sheila Rice, NeighborWorks Great Falls (NWGF). Ms. Rice thanked the CDC for their work and she spoke in support of the proposed Action Plan. She thanked the City for its longstanding commitment to affordable housing development. Ms. Rice related a 2010 publication from the National Institute of Home Builders noted NWGF created 42 jobs. She also pointed out how information from the Comprehensive Housing Affordability Strategy was recently cited in a Montana Board of Housing hearing in support of the Benefis senior housing project which was successfully granted tax credits. The Benefis project will create 42 units of low income senior housing. Ms. Rice indicated this is a reflection of the ripples that are created from affordable housing projects. In closing, Ms. Rice relayed the story of one of the people NWGF is working with and the changes she made in her life to be able to become a homeowner.



Agenda # 7
Commission Meeting Date:
May 3, 2011

**CITY OF GREAT FALLS
COMMISSION AGENDA REPORT**

Item: Construction Contract Award: 2011 Street Repairs, O.F. 1611.1
From: Engineering Division
Initiated By: Public Works Department
Presented By: Jim Rearden, Public Works Director
Action Requested: Consider Bids and Award Construction Contract

Suggested Motion:

1. Commissioner moves:

“I move the City Commission award a contract in the amount of \$396,690.00 to Great Falls Sand & Gravel, Inc. for the 2011 Street Repairs, O. F. 1611.1, and authorize the City Manager to execute the agreements.”

2. Mayor calls for a second, discussion, inquiries from the public, and calls for the vote.

Staff Recommendation: Approve construction contract award.

Background:

Significant Impacts

This project will repair several areas of roadway around town that have suffered sudden and severe deterioration due to freezing and thawing that occurred over the winter.

Workload Impacts

Public Works staff designed the project, and will perform construction inspection and contract administration duties.

Purpose

Large sections of road in several areas of the City have developed potholes and deep ruts. The original road foundation has been completely destabilized and requires replacement. Additional reinforcement and road base will be added to stabilize these areas. Since the subbase and supporting base course of the road has been compromised, additional deterioration of the road will continue until replacement of the road section is achieved. Additional replacement quantities may be added once excavation begins and the true extent of the damage can be determined.

Project Work Scope

Approximately 6,200 square yards of roadway will be rebuilt in eleven locations. This reconstruction consists of removing 3,100 cubic yards of unsuitable materials and replace it with pit run gravel, replacing 6,200 cubic yards of 12 inch depth base course, placing geogrid and geotextile reinforcement, and replacing 6,200 square yards of asphalt pavement. The locations and estimated quantities are summarized below.

<u>Location</u>	<u>Approx. Size</u>	<u>Square Yards</u>
6 th St NE & 29 th Ave NE	70' x 31'	241
400 Block of 22 nd Ave NE	150' x 31'	517
500 Block of 22 nd Ave NE	90' x 31'	310
Alder Drive – Juniper to Linden	102' x 32'	363
Juniper at Fox Farm Road	400' x 25'	1,111
Flood Road at Dixie Lane	250' x 25'	694
10 th St So. – Central to 1 st Ave So.	70' x 34'	264
41 st St & 6 th Ave No.	50' x 31'	172
400 Block of 53 rd St So.	118' x 31'	406
52 nd St So. – Sunrise Ave to 3 rd Ave So.	422' x 31'	1,454
5300 Block of 3 rd Ave So.	128' x 17'	242
	220' x 17'	416

Evaluation and Selection Process

Four bids were received and opened for this project on April 29, 2011. The bids ranged from \$396,690.00 to \$429,860.00. Great Falls Sand & Gravel, Inc. submitted the low bid and executed all the necessary bid documents. This project's bid and award schedule was accelerated to expedite construction to minimize further road deterioration and replacement costs. Construction milestones have been accelerated as well to ensure quick completion of the repairs.

Conclusion

City staff recommends awarding the construction contract to Great Falls Sand & Gravel, Inc. in the amount of \$396,690.00

Fiscal Impact:

The attached bid tabulation summarizes bids that were received. This project will be funded from the street maintenance fund. This project was not anticipated in the capital program, so the money spent on this project will replace a project previously programmed. The area of replacement has grown since The Commission was initially briefed on the project two weeks ago.

Alternatives:

The City Commission could vote to deny award of the construction contract.

Attachments/Exhibits:

1. Bid tabulation is attached.



Item: Provisionally Accredited Levee (PAL) Agreement for West Great Falls Levee

From: Michael Haynes, AICP, Planning and Community Development Director

Initiated By: Charlie Sheets, Development Review Coordinator

Presented By: Michael Haynes, AICP, Planning and Community Development Director

Action Requested: Accept PAL Agreement and authorize signature of the same.

Suggested Motion:

1. Commissioner moves:

“I move that the City Commission (accept and authorize signature/deny) Letter of Agreement and request Provisionally Accredited Levee (PAL) Designation as required for compliance with the Code of Federal Regulation.”

2. Mayor calls for a second, discussion, inquiries from the public, and calls the vote.

Recommendation: Staff recommends the City Commission accept and authorize signature of Letter of Agreement requesting Provisionally Accredited Levee (PAL) Designation, as required for compliance with the Code of Federal Regulation, Title 44, Section 65.10 (44 CFR 65.10).

Background: The West Great Falls Flood Control Levee is due for recertification. The Army Corps of Engineers (ACOE) has previously certified the integrity of levees throughout the U.S., including the West Great Falls Levee, but due to budget constraints and other issues ACOE is no longer certifying levees in Montana and other States. The Federal Emergency Management Agency (FEMA) has notified the West Great Falls Flood Control and Drainage District (WGFFCDD) that ACOE will no longer provide the recertification required to maintain the requirements of the Code of Federal Regulation 44 CFR 65.10. This certification is one part of the National Flood Insurance Program (NFIP) and helps the citizens living within the District get flood insurance coverage at reasonable rates.

FEMA is requesting that Cascade County, City of Great Falls and WGFFCDD all sign PAL agreements thereby allowing two (2) years for the West Great Falls Levee to be locally certified and allowing FEMA’s Flood Insurance Rate Maps (FIRM) to show properties on the landward side of the West Great Falls Levee as being in the 500-year floodplain and not the 100-year floodplain which has significant impact on flood insurance rates.

The deadline for signature of the PAL agreements is May 13, 2011, and all parties must sign for the agreements to be effective. WGFFCDD is meeting on the evening of May 2, 2011, to take action on the PAL agreement so their position will not be known until the day of the May 3, 2011, City Commission meeting to consider this action. Cascade County has scheduled action on the PAL if needed prior to the May 13, 2011, deadline set by FEMA.

By signing the PAL agreement, WGFFCDD would acknowledge ownership of the West Great Falls Levee and responsibility to provide within two years the data and documentation demonstrating compliance with 44 CFR 65.10. Cascade County and the City of Great Falls would sign PAL agreements that state that it is the responsibility of the levee owner (WGFFCDD) to submit the data and documentation required by 44 CFR 65.10 before FEMA can accredit the levee as providing protection from the base (1-percent-annual-chance) flood otherwise known as the “100-year floodplain”. The data and documentation will allow FEMA to move forward with the Digital Flood Insurance Rate Map (DFIRM) for City of Great Falls and Cascade County.

Should WGFFCDD or any other parties not sign the PAL Agreements, the West Great Falls Levee would not be certified and the DFIRM Maps would reflect the properties in the District as in the 100-year floodplain.

Concurrences: This recommendation is a collaborative effort of the West Great Falls Flood Control and Drainage District, Cascade County and the Planning and Community Development Staff.

Fiscal Impact: It is the responsibility of WGFFCDD to submit the data and documentation required by 44 CFR 65.10 in order to certify the levee as providing base flood protection. This will limit the flood insurance premiums paid by property owners that are within the area behind the levee known as “Sun River Left Bank-Stage 2 Flood Protection Project”. The requested action should not result in any increased cost to the City. It would require WGFFCDD to assess property owners in the District the costs of surveying the levee and any improvements identified as necessary to achieve certification.

Alternatives: If the PAL agreement is not employed, FEMA will move forward with their Flood Map Modernization program and the area landward of the de-accredited West Great Falls Levee will be shown as a high-risk flood zone based on the new approach for “without levee” analysis. This would result in substantially higher flood insurance rates for affected property owners.

Attachments/Exhibits: Letter of Agreement for Accredited Levee (PAL) Designation as required for compliance with the Code of Federal Regulation, Title 44, Section 65.10 (44 CFR65.10) and FEMA Figure 1. WGFFCDD Newsletter – April 21, 2011.

West Great Falls Flood Control & Drainage District

Newsletter – April 21, 2011

From: Your Commissioners – Ron Litostansky, Dan Kleinjan, & Sandy Mares
c/o 429-19th St. SW, Great Falls, MT 59404-2735 Phone: (406)727-8961

**** PUBLIC MEETING ****

Join us Monday, May 2, 2011, 7:00 pm, at the Knights of Columbus Hall, 906 Central Avenue West. The Agenda will include the following items for discussion:

Federal Emergency Management Agency (FEMA)

Levee (Re-) Certification and (Re-)Accreditation

Certification Cost Estimates and Analysis of Estimated Certification Cost Assessments
Revised FEMA 4/13/11 Provisionally Accredited Levee Agreement: 5/13/11 deadline
Invited Representatives for U.S. Senators Baucus & Tester & Congressman Rehberg
Request for Public Vote, yea or nay, on District signing of FEMA PAL Agreement

Increasing Maintenance Funding Needs, Budget, & Property Tax Assessments

Detailed Expenditures, Proposed \$75,000 Budget 7/1/11-6/30/12, & Cash Flow Analysis

Proposed Assessments 2011 Tax Year (Nov. 2011 first half; May 2012 second half):

Special Benefits Assessments 36.73% of Total Budget

	2010 Actual Assessments	2011 Proposed Assessments
	<u>36.73% x \$55,750 = \$20,480</u>	<u>36.73% x \$75,000 = \$27,548</u>
Cascade County (17.265%)	\$3,535.87	\$4,756.16
City of Great Falls (66.405%)	\$13,599.74	\$18,293.25
Great Falls Public Schools (7.305%)	\$1,496.06	\$2,012.38
MT Dept. Transportation (5.844%)	\$1,196.85	\$1,609.91
5 Utilities & 1 Railroad (3.181%)	\$651.46	\$876.30

General Assessments 63.27% of Total Budget

Market Value	Taxable Value	2010 Mills Assessment	Approx. * 2011* Assessment
		<u>63.27% x \$55,750 = \$35,270</u>	<u>63.27% x \$75,000 = \$47,452</u>
\$50,000	\$1,410*	at 27.77 mills = \$39.16	approx. 36.8mills* = \$51.89*
\$100,000	\$2,820*	at 27.77 mills = \$78.31	approx. 36.8mills* = \$103.78*
\$200,000	\$5,640*	at 27.77 mills = \$156.62	approx. 36.8mills* = \$207.55*

* 2011 Mills and General Assessments Amounts will change after receipt of MT Dept. of Revenue Certified Taxable Value Information towards the end of July 2011.

Submittal of Proposed 2011 Budget and Assessments to MT 8th Judicial District Court
Copy of Court Report @ Great Falls Public Library 4/27 through 6/30 for Public Review

2011 Flood Season

NO TRESPASSING on District Property

2011 Maintenance Season

Scheduled Maintenance thus far this season

Public Comments, Questions, etc.

If you would like to have something included on the Agenda, please call Sandy @ 727-8961 by 5pm 4/29. Hope to see you at our Public Meeting! Thank you for your support!



FEMA

FIGURE 1

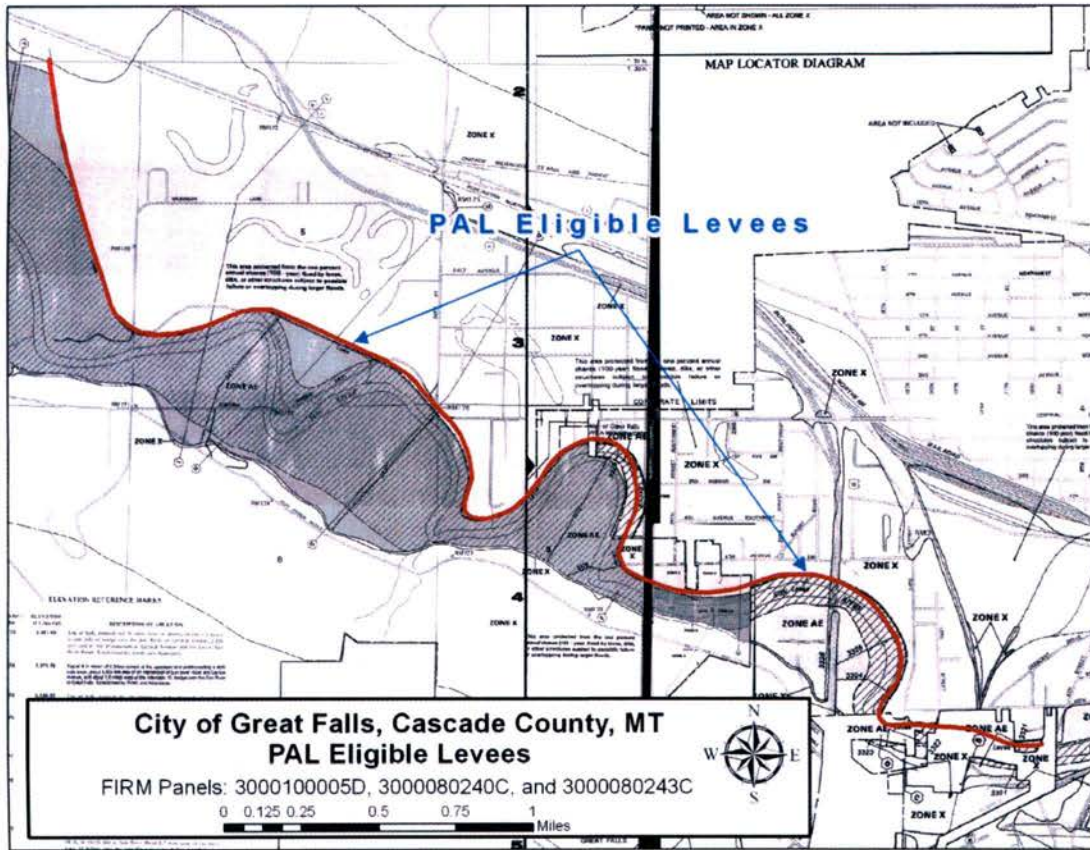

PAL Eligible Levees: On the North side of the Sun River from 6th Street upstream to approximately Green Meadow Drive.

Letter of Agreement to Comply With the Code of Federal Regulations, Title 44, Section 65.10 (44 CFR 65.10) and Request for Provisionally Accredited Levee (PAL) Designation

We, the undersigned, have received the letter from the Federal Emergency Management Agency (FEMA) dated April 13, 2011 and the enclosed document entitled "Requirements of 44 CFR 65.10." We understand that FEMA is in the process of providing an updated flood map, termed a Digital Flood Insurance Rate Map (DFIRM), for Cascade County, MT and that the area behind the levee known as Sun River Left Bank-Stage 2 Flood Protection Project will be remapped to reflect that the levee has been designated as a PAL.

We understand that all the necessary data and documentation to show that the levee known as Sun River Left Bank-Stage 2 Flood Protection Project complies with 44 CFR 65.10 will be required before May 13, 2013. In addition, we understand that it is the responsibility of the levee owner to submit the data and documentation required by 44 CFR 65.10 before FEMA can accredit the levee as providing protection from the base (1-percent-annual-chance) flood. The data and documentation will allow FEMA to move forward with the DFIRM for Cascade County, MT. We fully acknowledge that if complete data and documentation to comply with 44 CFR 65.10 are not provided within the designated timeframe of 24 months, FEMA will initiate a revision to the DFIRM to redesignate certain areas on the landward side of the levee as Special Flood Hazard Area, the area subject to inundation by the base flood.

In signing this Letter of Agreement we understand that the levee owner will commit to providing FEMA with the necessary data and documents demonstrating compliance with 44 C.F.R. 65.10 within the timeframes specified in herein and does not constitute a warranty or guarantee of performance, expressed or implied, as to how the levee will perform in a flood event.

Non-Levee Owner Community CEO _____ (signature)

_____ (print)

Date: _____

Other (if applicable) _____ (signature)

_____ (print)

Date: _____

Regular City Commission Meeting

Mayor Winters presiding

CALL TO ORDER: 7:00 PM

PLEDGE OF ALLEGIANCE – 120th Fighter Wing Honor Guard

MOMENT OF SILENCE

ROLL CALL: City Commissioners present: Michael Winters, Bill Bronson, Fred Burow, Mary Jolley and Bob Jones. Also present were the City Manager, Deputy City Manager, City Attorney, Directors of Fiscal Services and Planning and Community Development, the Public Works Engineer, Executive Director of the Housing Authority, Library Administrative Assistant, Police Chief and the City Clerk.

PROCLAMATIONS: Mayor Winters read a proclamation for Fair Housing Month.

**** Action Minutes of the Great Falls City Commission. Please refer to the audio recording of this meeting for additional detail. ****

NEIGHBORHOOD COUNCILS

1. MISCELLANEOUS REPORTS AND ANNOUNCEMENTS.

There were no miscellaneous reports and announcements from Neighborhood Council representatives.

BOARDS & COMMISSIONS

2. REAPPOINTMENT, LIBRARY BOARD.

Commissioner Jolley moved, seconded by Commissioners Burow and Jones, that the City Commission reappoint Judy Riesenberg to the Library Board for a five-year term through June 30, 2016.

Mayor Winters asked if there was any discussion amongst the Commissioners or inquiries from the public. Hearing none, Mayor Winters called for the vote.

Motion carried 5-0.

3. REAPPOINTMENTS, HISTORIC PRESERVATION ADVISORY COMMISSION.

Commissioner Bronson moved, seconded by Commissioner Burow, that the City Commission reappoint Ryan Forde and Bob Milford to the Historic Preservation Advisory Commission for three-year terms through April 30, 2014.

Mayor Winters asked if there was any discussion amongst the Commissioners or inquiries from the public. Hearing none, Mayor Winters called for the vote.

Motion carried 5-0.

4. MISCELLANEOUS REPORTS AND ANNOUNCEMENTS.

There were no miscellaneous reports and announcements from members of boards and commissions.

PUBLIC HEARINGS

5. 2011/2012 CDBG AND HOME ANNUAL ACTION PLAN.

Planning and Community Development Director Mike Haynes reported that the requested action is to conduct the public hearing on the Annual Action Plan for allocation of 2011/2012 CDBG and HOME funding and schedule action on the Final Annual Action Plan for May 3, 2011. The recommendations are those of the Community Development Council (CDC) after hearing requests for funds from all eligible applicants and then meeting to prioritize funding requests.

The federal budget was approved for this year, and it appears the City can anticipate 16.5% less funding for CDBG and at least 12% less funding for the HOME program than in 2010/2011. It is also clear that there will be additional reductions in CDBG and HOME funding levels in future years.

Mayor Winters declared the public hearing open.

No one spoke in opposition to the 2011/2012 CDBG and HOME Annual Action Plan.

Speaking in support of the 2011/2012 CDBG and HOME Annual Action Plan were:

Nancy Wilson, Meals on Wheels; **Brett Doney**, Great Falls Development Authority; **John Stephenson-Love**, Upper Lower River Road Water and Sewer District; and, **Sheila Rice**, NeighborWorks.

Mayor Winters declared the public hearing closed.

Commissioner Jones moved, seconded by Commissioner Jolley, that the City Commission schedule action on the Final Annual Action Plan for May 3, 2011.

Mayor Winters asked if there was any discussion amongst the Commissioners. Hearing none, Mayor Winters called for the vote.

Motion carried 5-0.

OLD BUSINESS

6. ORDINANCE 3069 AMENDING TITLE 6 TO ESTABLISH REGULATIONS FOR KEEPING CHICKENS, ALL PERTAINING TO THE OFFICIAL CODE OF THE CITY OF GREAT FALLS.

Planning and Community Development Director Mike Haynes reported that, on April 5, 2011, after

conducting and closing the public hearing to consider three Ordinances related to Urban Chickens, Commissioner Bronson's motion to adopt Ordinance 3069 with amendments was defeated. A vote was not then taken on Ordinance 3069 itself. Therefore, staff recommends that the City Commission take action on Ordinance 3069.

Commissioner Jones moved, seconded by Commissioner Burow, that the City Commission deny Ordinance 3069.

Mayor Winters asked if there was any discussion amongst the Commissioners.

Commissioner Jones commented on the number of phone calls and emails received, and the time and effort put into this matter. He pointed out that a couple of Neighborhood Councils that represent a large portion of the community were opposed to chickens. He also noted that some homeowner covenants do not allow livestock or poultry.

Commissioner Jolley commented that a majority of the people that appeared were in favor of chickens, as well as those that appeared at the zoning hearing. She expressed that the public hearing is where the information should be provided so that citizens can hear what their fellow citizens are saying. She urged the Commission not to vote to deny chickens.

Commissioner Bronson also noted the number of emails and phone calls received. He commented that, as elected officials, if a proposal is put before the Commission that makes sense, then it deserves their fair consideration. He also noted that there are covenants in many parts of the community that forbid people from having any type of poultry. He does believe there are areas in town where this could still be done in accordance with a properly drafted ordinance. He suggested referring this matter to a committee to address issues and concerns and then bringing the matter back before this body.

Mayor Winters also commented on the amount of communications received in this matter, and that the Commissioners vote according to their own views of the information received.

Mayor Winters asked if there were any comments from the public.

Channing Hartelius, 825 4th Avenue North, discussed parliamentary procedure. He believes that it was improper procedure to put forth a motion to deny that which has already been proposed to be accepted; and, that the motion to refer to committee, if seconded, would be proper.

City Attorney James Santoro added that the original motion was to accept Ordinance 3069 on first reading and to set a public hearing. He explained that it has been the practice to adopt or deny ordinances on second reading. It comes down to the intent of the Commission and what the intent of the motion was.

Commissioner Bronson noted that the City is also bound by state statutes which set forth the procedures by which the Commission considers ordinances and resolutions. It has always been his understanding, based on past practice, that when the Commission votes on an ordinance on first reading, the Commission is simply accepting it as a first reading, and the actual public hearing and debate are held at the next meeting.

Aart Dolman, 3016 Central Avenue, commented that there is a purpose for a public hearing, and it does not mean hearing the public by telephone or email. He hoped that the Commissioners would make their phone calls and email information available to the public.

Ron Gessaman, 1006 36th Avenue NE, concurred with Mr. Dolman. He commented that a public hearing is a quasi-judicial hearing. The testimony presented must be all the testimony the Commission takes into account.

Mayor Winters disagreed with Mr. Gessaman.

Channing Hartelius, 825 4th Avenue North, provided an example that, in court, anonymous information is considered hearsay and is not permitted or relied upon.

Commissioner Bronson disagreed with the interpretation that the Commission is engaged in a quasi-judicial proceeding. The Commission is functioning as a legislative body when considering the adoption of an ordinance. In those situations it is common that members of the Commission will hear from members of the public by word on the street, email or telephone conversation. He knows of no legal requirement that requires all emails and telephone conversations to be documented and made part of the official record for the consideration of an ordinance. Those concerns would be valid if the Commission was considering a zoning change where, in that situation, the Commission is functioning in a quasi-judicial capacity.

Channing Hartelius, 825 4th Avenue North, spoke in support of Commissioner Bronson's motion to refer to committee as the best way to handle this matter.

Sam Boor, no address provided, commented that he is a retired physician. He thinks the public is reacting to the lack of discussion of the issues regarding chickens. He supported the idea of referring this matter to a committee.

Mike Witsoe, 510 11th Street South, commented that the Commissioners' telephone numbers are listed on their City business cards for the public to contact them. He made accusatory statements that the Mayor was not listening to the public.

Sandra Dimauro, 4215 7th Avenue North, commented that at a recent Earth Day event she provided petitions and obtained signatures regarding chickens.

Commissioner Bronson moved, seconded by Commissioner Jolley, that the City Commission refer Ordinance 3069 to a committee of this Commission, consisting of himself and one other member appointed by the Mayor, for the purpose of (1) considering amendments to Ordinance 3069, particularly a consent requirement with appeal procedures; and (2) gathering and then presenting information to the Commission on the subject of a referendum, and the costs associated with that process. This committee to conduct its discussions and to report back to the Commission within 20 days with recommendations and information.

Commissioner Bronson explained that, as part of that motion, he contemplates conferring with Mr. Santoro regarding the procedural requirements should the committee come back with a proposal in an amended form. He further explained that his motion to refer to committee has priority over a motion to adopt or deny an ordinance.

Commissioner Jolley requested and received clarification that the committee will consider the option of putting this matter on the ballot.

Commissioner Jones noted he would be pleased to sit on the committee with Commissioner Bronson.

Commissioner Burow encouraged finality to this matter.

Commissioner Jones explained that, as an elected official with another job, the telephone and email are ways he can communicate with the public. He disagreed with Mr. Dolman's comments.

Commissioner Bronson concluded that this body is made up of five individuals who try to do the best they can, with the information they have, based on the experiences they have in life.

Commissioner Jolley noted that she didn't agree with most of what the other Commissioners said here tonight.

There being no one further to address the Commission, Mayor Winters called for the vote on the motion to refer Ordinance 3069 to a committee.

Motion carried 5-0.

Mayor Winters noted that he would also like to sit on this committee with Commissioners Bronson and Jones.

NEW BUSINESS

7. PROFESSIONAL SERVICES AGREEMENT, MUNICIPAL BUILDING ENERGY AUDIT CONTRACT, OF 1621.

Planning and Community Development Director Mike Haynes reported that this item relates to a Professional Services Contract to conduct an energy audit of six municipal buildings: the Civic Center, Police Station, Fire Stations #1 and #2, the Library and the Central Garage. This is one of the final expenditures of \$570,100 in Energy Efficiency and Conservation Block Grant funds secured by the Planning and Community Development Department from the Department of Energy and accepted by the City Commission in late 2009.

Ten bids were received in response to an RFQ. An Energy Audit Committee reviewed all proposals and the highest score was received by the engineering firm Morrison Maierle, Inc.

Commissioner Bronson moved, seconded by Commissioners Burow and Jones, that the City Commission approve the Professional Services Agreement for a fee not to exceed \$68,872 with Morrison Maierle, Inc. for the Municipal Building Energy Audit, and authorize the City Manager to execute the agreement.

Mayor Winters asked if there was any discussion amongst the Commissioners. Hearing none, Mayor Winters asked if there were any inquiries from the public.

Ron Gessaman, 1006 36th Avenue NE, inquired about the delay from the time the monies were

received and this contract award.

Mr. Haynes explained that this is number seven out of seven projects funded by these grant funds.

There being no one else to address the Commission, Mayor Winters called for the vote.

Motion carried 5-0.

8. MILITARY ENTRYWAY SIGNAGE.

Mayor Michael Winters reported that, to recognize our community's military history, the Commission and staff have discussed installing entryway signage reading "Proud Home of Malmstrom Air Force Base & Montana Air National Guard." A request for designs was advertised, and the Deputy City Manager has prepared a basic cost analysis.

Commissioner Jones moved, seconded by Commissioner Bronson, that the City Commission authorize the City Manager to spend funded contingency funds in an amount not to exceed \$25,000 to construct military entryway signage.

Mayor Winters asked if there was any discussion amongst the Commissioners.

Commissioner Jones commented that this sign is proposed for the 10th Avenue South - 57th Street South entryway. He expressed concerns about the cost and hoped there would be voluntary pledges.

Commissioner Burow also expressed concerns about the cost and the upcoming budget.

City Manager Doyon explained that the City designates contingency funds for the year for expenditures that weren't anticipated.

Commissioner Jolley doesn't believe this is a proper use of contingency funds. She urged the Commission to vote no. She suggested that community members and businesses come forward to donate money.

Commissioner Bronson commented that this is an appropriate first step. He anticipates folks in the private sector will step up and participate as well.

Commissioner Burow inquired if labor could be donated to offset the cost.

Mayor Winters noted several organizations that expressed interest in helping with this project.

Mayor Winters asked if there were any inquiries from the public.

Ron Gessaman, 1006 36th Avenue NE, commented that the Army is being left out.

Commissioner Jones responded that would be looked at. He commented that the Army Reserve has a new facility at Malmstrom Air Force Base. The purpose for the signage is to identify what "we are home to."

Commissioner Jolley commented that, technically, Great Falls is not the home, but the neighbor, of Malmstrom Air Force Base.

Brett Doney, Great Falls Development Authority, residing at 3048 Delmar Drive, commented this compliments what the Chamber of Commerce, Defense Alliance and Cascade County are doing with 2nd Avenue North that leads into the main entrance of the base.

Mike Witsoe, 510 11th Street South, inquired about the design specifications, and he suggested this matter be continued for two weeks.

Deputy City Manager Jennifer Reichelt clarified that the action tonight, if approved, is granting staff permission to obtain estimates to move forward with this project.

Motion carried 3-2 (Commissioners Burow and Jolley dissenting).

ORDINANCES/RESOLUTIONS

CONSENT AGENDA

9. Minutes, April 5, 2011, Commission meeting.
10. Total expenditures of \$1,918,222 for the period of March 31 through April 13, 2011, to include claims over \$5,000, in the amount of \$1,684,031.
11. Contracts list.
12. Lien release list.
13. Grant list.

Commissioner Jolley moved, seconded by Commissioner Bronson, that the City Commission approve the Consent Agenda as presented.

Mayor Winters asked if there was any discussion amongst the Commissioners. Hearing none, Mayor Winters asked if there were any inquiries from the public.

Ron Gessaman, 1006 36th Avenue NE, referred to Item 9 and commented there was no mention that the public hearing was closed with regard to Victory Christian Center. With regard to Item 11B, Mr. Gessaman commented he has a hard time believing it costs over \$12,000 to time the Ice Breaker race.

Commissioner Burow inquired if the City makes money from the Ice Breaker race.

Fiscal Services Director Melissa Kinzler responded that there are corporate sponsors that offset the cost of the Ice Breaker. The City usually breaks even on this community event.

Motion carried 5-0.

PETITIONS AND COMMUNICATIONS**14. MISCELLANEOUS REPORTS AND ANNOUNCEMENTS.**

Mayor Winters opened the meeting to Petitions and Communications.

- A. Aart Dolman**, 3016 Central Avenue, provided a letter that requested all of the Commissioners' telephone calls and emails regarding the three ordinances concerning chickens within 15 days. It was his belief the Commission violated open meeting laws.

In response to Commissioner Jolley about a March 1st request, Mr. Dolman commented that he previously requested three items, one of which was what authorization does the City have to give money to ECP.

With regard to the ordinances concerning chickens, Commissioner Jolley commented that she returned no telephone calls.

- B. Bill Garberg**, 1712 19th Avenue South, requested, on behalf of the Great Falls Vets Center and Vets4Vets, support from the City in the form of a parcel of land with access to a water system for a Veterans Community Garden.
- C. John Hubbard**, 615 7th Avenue South, expressed opposition to the school levy; discussed the recession and the need for more jobs in Great Falls; and, he expressed frustration with the judicial system.
- D. Ron Gessaman**, 1006 36th Avenue NE, announced that an ECP Board meeting was scheduled for tomorrow afternoon.
- E. Cyndi Baker**, 500 Montana Avenue NW, discussed the water quality report contained in the water bills. She attested that Great Falls has the best tasting water in the world.

CITY MANAGER**15. MISCELLANEOUS REPORTS AND ANNOUNCEMENTS.**

City Manager Greg Doyon reported that an ECP meeting was scheduled for tomorrow night. Mr. Doyon also provided a levy status update.

CITY COMMISSION**16. MISCELLANEOUS REPORTS AND ANNOUNCEMENTS.**

There were no miscellaneous reports and announcements from the City Commissioners.

ADJOURNMENT

There being no further business to come before the regular Commission meeting, **Commissioner Bronson moved, seconded by Commissioner Jones, that the regular meeting of April 19, 2011, be adjourned at 8:46 p.m.**

Motion carried 5-0.

Mayor Winters

City Clerk

Minutes Approved: May 3, 2011



ITEM: \$5,000 Report
Invoices and Claims in Excess of \$5,000

PRESENTED BY: Fiscal Services Director

ACTION REQUESTED: Approval with Consent Agenda

LISTING OF ALL ACCOUNTS PAYABLE CHECKS ISSUED AVAILABLE ONLINE AT
www.greatfallsmt.net/people_offices/fiscal/checkregister.php

TOTAL CHECKS ISSUED AND WIRE TRANSFERS MADE ARE NOTED BELOW WITH AN ITEMIZED LISTING OF ALL TRANSACTIONS GREATER THAN \$5000:

ACCOUNTS PAYABLE CHECK RUNS FROM APRIL 14 - 20, 2011	1,321,166.37
MUNICIPAL COURT ACCOUNT CHECK RUN FOR APRIL 9 - 18, 2011	62,878.46
MUNICIPAL COURT ACCOUNT CHECK RUN FOR APRIL 19 - 25, 2011	4,911.00
WIRE TRANSFERS FROM APRIL 14 - 20, 2011	42,598.72
WIRE TRANSFERS FROM APRIL 21 - 27, 2011	<u>138,065.44</u>
TOTAL: \$	<u><u>1,569,619.99</u></u>

SPECIAL REVENUE FUND

CTEP PROJECT

THOMAS DEAN & HOSKINS INC	OF1126.9 BAY DRIVE PHASE II CONSULTANT SERVICES SEPT 2010 - DEC 2010	24,116.67
---------------------------	--	-----------

STREET DISTRICT

UNITED MATERIALS OF GREAT FALLS	ASPHALT	5,327.75
HUSKY OIL MARKETING COMPANY	WSPE 1 TOTES (COUNTY PORTION \$4,400)	8,798.43

LIBRARY

EBSCO INDUSTRIES INC	SUBSCRIPTIONS (SPLIT AMONG FUNDS)	5,986.49
----------------------	-----------------------------------	----------

LIBRARY FOUNDATION

EBSCO INDUSTRIES INC	SUBSCRIPTIONS (SPLIT AMONG FUNDS)	109.00
----------------------	-----------------------------------	--------

PARK & RECREATION SPECIAL REVENUE

ADVANTAGE/THOMCO	WINDSCREEN FOR TENNIS COURTS	6,608.00
------------------	------------------------------	----------

CAPITAL PROJECTS

GENERAL CAPITAL

A T KLEMENS INC	PUBLIC WORKS ADMIN REPLACE BOILER	26,444.04
-----------------	-----------------------------------	-----------

ENTERPRISE FUNDS

WATER

DANA KEPNER COMPANY INC	510R MXU RADIO READ UNITS	5,805.00
-------------------------	---------------------------	----------

SEWER

VEOLIA WATER NORTH AMERICA	APRIL WWTP OPERATION CONTRACT	246,806.34
VEOLIA WATER NORTH AMERICA	APRIL CONTRACTED CAPITAL IMPROVEMENTS	12,500.00
NCI ENGINEERING COMPANY	PMT 1 OF1457.5 LIFT STATION 10, 12 AND 25 CAN REPLACEMENTS AND MISC IMPROVE	27,961.50

STORM DRAIN

PHILLIPS CONSTRUCTION	FINAL OF1538 7TH AVE NW STORM DRAIN EXTENSION	26,124.12
-----------------------	---	-----------

SANITATION

SOLID WASTE SYSTEMS INC	150 EA 300 GALLON PLASTIC CONTAINERS	41,850.00
-------------------------	--------------------------------------	-----------

PARKING

APCOA/STANDARD PARKING	MAY 2011 COMPENSATION	25,339.82
------------------------	-----------------------	-----------

GOLF COURSES

STRAY MOOSE PRODUCTIONS	14 NEW GOLF CARS LESS TRADE-IN	35,000.00
-------------------------	--------------------------------	-----------

CIVIC CENTER EVENTS

VISION NET INC	LONG THROW PROJECTOR FOR MANSFIELD THEATER	9,732.49
----------------	--	----------

INTERNAL SERVICES FUND

HEALTH & BENEFITS

BLUE CROSS/BLUE SHIELD	HEALTH INS CLAIMS APRIL 12 - 18, 2011	83,416.42
BLUE CROSS/BLUE SHIELD	HEALTH INS CLAIMS APRIL 19 - 25, 2011	138,065.44

FISCAL SERVICES

BASIN CREEK POWER SERVICES LLC	CONSULTING FEES FOR ECP RATES THROUGH FEBRUARY 2011	10,000.00
--------------------------------	---	-----------

INFORMATION TECHNOLOGY

QWEST COMMUNICATIONS CO LLC	1.5 MONTHS ISP CHARGES 45MB SERVICE \$2,000 INSTALLATION CHARGES	8,551.73
-----------------------------	--	----------

CENTRAL GARAGE

MOUNTAIN VIEW CO-OP	FUEL	59,210.94
---------------------	------	-----------

CC FACILITY SERVICES

A T KLEMENS INC	PMT 7 HVAC SYSTEM IN MANSFIELD THEATER	12,488.85
-----------------	--	-----------

TRUST AND AGENCY

COURT TRUST MUNICIPAL COURT

CITY OF GREAT FALLS	FINES & FORFEITURES COLLECTIONS	60,795.46
---------------------	---------------------------------	-----------

PAYROLL CLEARING

STATE TREASURER	MONTANA TAXES	36,163.00
ICMA RETIREMENT TRUST	EMPLOYEE CONTRIBUTIONS	12,003.73
FIREFIGHTER RETIREMENT	FIREFIGHTER RETIREMENT EMPLOYEE & EMPLOYER CONTRIBUTIONS	43,767.05
STATEWIDE POLICE RESERVE FUND	POLICE RETIREMENT EMPLOYEE & EMPLOYER CONTRIBUTIONS	54,351.85
PUBLIC EMPLOYEE RETIREMENT	PUBLIC EMPLOYEE RETIREMENT EMPLOYEE & EMPLOYER CONTRIBUTIONS	91,909.03
POLICE SAVINGS & LOAN	EMPLOYEE CONTRIBUTIONS	11,839.00
1ST INTERSTATE BANK	FEDERAL TAXES, FICA & MEDICARE	163,220.22
AFLAC	EMPLOYEE CONTRIBUTIONS	12,218.17

UTILITY BILLS

MONTANA WASTE SYSTEMS INC	MARCH 2011 CHARGES	60,091.79
QWEST	APRIL 2011 911 CHARGES	5,850.26

CLAIMS OVER \$5000 TOTAL:		\$ <u>1,372,452.59</u>
----------------------------------	--	-------------------------------

City of Great Falls

Check Details Report (Date: 04/27/2011)

Account#	Check#	VendorName	Vendor#	Invoice#	Amount
6080-71-761-49310	213898	A T KLEMENS INC	84	I11-002096	\$ 12,488.85
6080-71-761-42230	213899	ACE HARDWARE	4876	I11-002224	\$ 35.96
6080-71-761-43620	213899	ACE HARDWARE	4876	I11-002224	\$ 26.19
6080-71-761-42230	213899	ACE HARDWARE	4876	I11-002287	\$ 19.97
6080-71-761-43410	213952	FSH COMMUNICATIONS	12068	I11-002481	\$ 65.00
6080-71-761-43620	213970	J & V RESTAURANT & FIRE SUPPLY	6109	I11-002222	\$ 279.70
6080-71-761-43420	214007	NORTHWESTERN ENERGY	82	I11-002647	\$ 91.51
6080-71-761-42230	214063	ACE HARDWARE	4876	I11-002542	\$ 12.99
6080-71-761-42350	214063	ACE HARDWARE	4876	I11-002547	\$ 8.08
6080-71-761-42350	214063	ACE HARDWARE	4876	I11-003006	\$ 78.04
6080-71-761-42350	214094	BRENNAN HEATING & COOLING	2511	I11-003015	\$ 13.20
6080-71-761-42350	214097	CASCADE MACHINE & SUPPLY	12753	I11-002549	\$ 50.40
6080-71-761-43620	214100	COLUMBIA PAINT & COATINGS	50	I11-002707	\$ 335.34
6080-71-761-43620	214109	Dick Boettcher Painting	12726	I11-002706	\$ 575.00
6080-71-761-43620	214117	ENTERPRISE ELECTRIC INC	2370	I11-002540	\$ 88.10
6080-71-761-43620	214141	J & V RESTAURANT & FIRE SUPPLY	6109	I11-002702	\$ 19.60
6080-71-761-42230	214165	MASCO JANITORIAL SUPPLY	198	I11-002573	\$ 22.74
6080-71-761-42230	214165	MASCO JANITORIAL SUPPLY	198	I11-002574	\$ 10.85
6080-71-761-42230	214170	MONTANA BROOM & BRUSH COMPANY	7828	I11-003007	\$ 62.08
6080-71-761-49310	214181	MT DEPT OF REVENUE 1% WITHHOLDING	136	I11-002232	\$ 126.15
6080-71-761-42350	214189	NORTHWEST PIPE FITTINGS INC	142	I11-003019	\$ 5.86
6080-71-761-43420	214190	NORTHWESTERN ENERGY	82	I11-002931	\$ 10.24
6080-71-761-42290	214204	Rasco Janitorial Supply	12726	I11-003013	\$ 48.48

					Fund(6080) Total\$14,474.33
2210-64-631-43690	214064	ADVANTAGE/THOMCO	5396	I11-002858	\$ 6,608.00

					Fund(2210) Total\$6,608.00
5310-31-564-49320	214002	NCI ENGINEERING COMPANY	12508	I11-002428	\$ 27,961.50
5310-31-565-42190	214012	PETTY CASH/STRENDING DEE	420	I11-002745	\$ 13.99
5310-31-565-43110	214012	PETTY CASH/STRENDING DEE	420	I11-002745	\$ 18.79

City of Great Falls

Check Details Report (Date: 04/27/2011)

Account#	Check#	VendorName	Vendor#	Invoice#	Amount
5310-31-565-42140	214012	PETTY CASH/STRENDING DEE	420	I11-002745	\$ 19.00
5310-31-565-43410	214055	WCS TELECOM	11222	I11-002358	\$ 6.26
5310-31-565-43350	214068	AMERICAN WATER WORKS ASSOC	200	I11-002904	\$ 165.00
5310-31-565-43690	214086	BIG SKY HYDRAULICS & MACHINING INC	11168	I11-002895	\$ 39.50
5310-31-564-43790	214143	JACOBSON MIKE	429	I11-003059	\$ 91.80
5310-31-564-43790	214166	MASTERCARD PROCESSING CENTER	8270	I11-002639	\$ 59.85
5310-31-565-43350	214179	MT DEPT OF ENVIRONMENTAL QUALITY	6565	I11-002961	\$ 30.00
5310-31-565-43350	214179	MT DEPT OF ENVIRONMENTAL QUALITY	6565	I11-002965	\$ 40.00
5310-31-565-43350	214179	MT DEPT OF ENVIRONMENTAL QUALITY	6565	I11-002968	\$ 40.00
5310-31-565-42390	214189	NORTHWEST PIPE FITTINGS INC	142	I11-002896	\$ 99.23
5310-31-564-43590	214239	VEOLIA WATER NORTH AMERICA	11147	I11-002888	\$ 10,949.25
5310-31-564-43590	214239	VEOLIA WATER NORTH AMERICA	11147	I11-002888	\$ 235,857.09
5310-31-564-49410	214239	VEOLIA WATER NORTH AMERICA	11147	I11-002888	\$ 12,500.00
5310-31-564-43350	214243	WATER ENVIRONMENT FEDERATION	3724	I11-003057	\$ 98.00

5710-32-264-43590	213984	MASTERCARD PROCESSING CENTER	8270	Fund(5310) Total I11-002634	\$287,989.26 \$ 15.00
5710-32-195-43790	214112	DOYON GREGORY T	12958	I11-003134	\$ 224.40
5710-32-195-43790	214166	MASTERCARD PROCESSING CENTER	8270	I11-003112	\$ 25.71
5710-32-195-43790	214166	MASTERCARD PROCESSING CENTER	8270	I11-003112	\$ 62.73
5710-32-195-43790	214166	MASTERCARD PROCESSING CENTER	8270	I11-003112	\$ 18.00
5710-32-195-43790	214166	MASTERCARD PROCESSING CENTER	8270	I11-003112	\$ 83.39
5710-32-195-43790	214166	MASTERCARD PROCESSING CENTER	8270	I11-003112	\$ 83.39

5711-64-673-43810	213963	HEART BEAT TRAINING CENTER TINA	9752	Fund(5710) Total I11-002461	\$512.62 \$ 14.25
5711-64-671-43810	213963	HEART BEAT TRAINING CENTER TINA	9752	I11-002461	\$ 14.25
5711-64-673-42350	213983	MASCO JANITORIAL SUPPLY	198	I11-002455	\$ 6.60
5711-64-671-42520	213995	MOUNTAIN VIEW CO-OP	972	I11-002456	\$ 59.78
5711-64-675-43420	214007	NORTHWESTERN ENERGY	82	I11-002647	\$ 7.10
5711-64-671-43410	214018	QWEST	81	I11-002448	\$ 27.31
5711-64-675-43410	214018	QWEST	81	I11-002451	\$ 27.31

City of Great Falls

Check Details Report (Date: 04/27/2011)

Account#	Check#	VendorName	Vendor#	Invoice#	Amount
5711-64-673-42290	214027	SAMS CLUB	4909	I11-002463	\$ 33.64
5711-64-673-42350	214063	ACE HARDWARE	4876	I11-002764	\$ 6.48
5711-64-671-42350	214063	ACE HARDWARE	4876	I11-002936	\$ 20.98
5711-64-673-42220	214098	CHEMICAL MONTANA COMPANY	2321	I11-000085	\$ -50.00
5711-64-673-42220	214098	CHEMICAL MONTANA COMPANY	2321	I11-000648	\$ -1,045.00
5711-64-673-42220	214132	HAWKINS INC WATER	6715	I11-002854	\$ 524.90
5711-64-671-42350	214148	JOHNSON MADISON LUMBER INC	9	I11-002855	\$ 55.90
5711-64-673-42350	214165	MASCO JANITORIAL SUPPLY	198	I11-002765	\$ 31.44
5711-64-671-42350	214183	NAPA AUTO PARTS OF GREAT FALLS	68	I11-002937	\$ 2.09
5711-64-671-43420	214190	NORTHWESTERN ENERGY	82	I11-002931	\$ 66.46
5711-64-673-43410	214203	QWEST	81	I11-002856	\$ 50.99

					Fund(5711) Total\$-145.52
2251-71-711-43310	213959	GREAT FALLS TRIBUNE	77	I11-002417	\$ 104.60
2251-71-711-43310	213959	GREAT FALLS TRIBUNE	77	I11-002417	\$ 154.20
2251-71-711-43310	213959	GREAT FALLS TRIBUNE	77	I11-002417	\$ 155.80
2251-71-711-43310	213959	GREAT FALLS TRIBUNE	77	I11-002417	\$ 106.20
2251-71-711-43310	213959	GREAT FALLS TRIBUNE	77	I11-002417	\$ 119.00
2251-71-711-43310	213959	GREAT FALLS TRIBUNE	77	I11-002417	\$ 106.20
2251-71-711-43590	213972	JJ'S BAKERY	13478	I11-002032	\$ 40.00
2251-71-711-42190	213984	MASTERCARD PROCESSING CENTER	8270	I11-001949	\$ 109.98
2251-71-717-43790	214031	SIEVERT ELLEN	9796	I11-002286	\$ 90.78
2251-71-711-43350	214067	AMERICAN PLANNING ASSOCIATION	12381	I11-002862	\$ 450.00
2251-71-711-43350	214067	AMERICAN PLANNING ASSOCIATION	12381	I11-002864	\$ 160.00
2251-71-717-43320	214166	MASTERCARD PROCESSING CENTER	8270	I11-003026	\$ 50.00
2251-71-717-43210	214166	MASTERCARD PROCESSING CENTER	8270	I11-003026	\$ 20.35

					Fund(2251) Total\$1,667.11
5210-00-000-21430	0	HOFFMAN, KIRSTEN & DONNIE	1679	I11-001802	\$ 1.11
5210-31-556-42290	213900	ACE INDUSTRIAL SUPPLY	11366	I11-002229	\$ 165.55
5210-31-555-43310	213959	GREAT FALLS TRIBUNE	77	I11-002638	\$ 867.24
5210-31-553-42290	213961	HACH CHEMICAL CO	126	I11-002297	\$ 772.00

City of Great Falls

Check Details Report (Date: 04/27/2011)

Account#	Check#	VendorName	Vendor#	Invoice#	Amount
5210-31-553-42290	213961	HACH CHEMICAL CO	126	I11-002297	\$ 367.60
5210-31-553-42290	213961	HACH CHEMICAL CO	126	I11-002297	\$ 59.95
5210-00-000-21430	213986	METHENY, BARRY W & KARI L	1679	I11-002506	\$ 33.02
5210-31-555-42290	214001	NATIONAL LAUNDRY	388	I11-002311	\$ 121.11
5210-31-555-43420	214007	NORTHWESTERN ENERGY	82	I11-002647	\$ 44.09
5210-31-556-43110	214012	PETTY CASH/STRENDING DEE	420	I11-002745	\$ 5.54
5210-31-556-43735	214012	PETTY CASH/STRENDING DEE	420	I11-002745	\$ 26.78
5210-31-555-42290	214014	PROBUILD	25	I11-002317	\$ 10.74
5210-31-556-42290	214025	S & M Water Consultants	12648	I11-002743	\$ 74.00
5210-31-556-42290	214026	S & M Water Consultants	12648	I11-002744	\$ 72.00
5210-31-556-43410	214055	WCS TELECOM	11222	I11-002358	\$ 6.54
5210-31-555-42290	214063	ACE HARDWARE	4876	I11-003107	\$ 4.99
5210-31-555-42390	214078	BEARING SALES INC	37	I11-003058	\$ 42.72
5210-31-556-42290	214085	BIG R STORES (CSWW INC)	40	I11-002902	\$ 10.87
5210-31-556-42290	214085	BIG R STORES (CSWW INC)	40	I11-002903	\$ 26.98
5210-31-555-42390	214085	BIG R STORES (CSWW INC)	40	I11-003066	\$ 0.00
5210-31-555-42390	214085	BIG R STORES (CSWW INC)	40	I11-003067	\$ 119.99
5210-31-555-42390	214097	CASCADE MACHINE & SUPPLY	12753	I11-003069	\$ 18.85
5210-31-555-42390	214097	CASCADE MACHINE & SUPPLY	12753	I11-003071	\$ 29.95
5210-31-555-42220	214098	CHEMICAL MONTANA COMPANY	2321	I11-003073	\$ 2,718.25
5210-31-555-42330	214101	CONSOLIDATED ELECTRICAL DIST INC	52	I11-003079	\$ 22.32
5210-31-555-42290	214101	CONSOLIDATED ELECTRICAL DIST INC	52	I11-003097	\$ 7.76
5210-31-555-42290	214102	CRESCENT ELECTRIC SUPPLY CO	405	I11-002822	\$ 79.80
5210-31-556-49610	214103	DANA KEPNER COMPANY INC BILLINGS	4982	I11-002654	\$ 1,974.00
5210-31-556-49610	214103	DANA KEPNER COMPANY INC BILLINGS	4982	I11-002749	\$ 2,025.00
5210-31-556-49610	214103	DANA KEPNER COMPANY INC BILLINGS	4982	I11-002749	\$ 3,780.00
5210-31-553-43590	214116	ENERGY LABORATORIES INC	813	I11-002730	\$ -172.00
5210-31-553-43590	214116	ENERGY LABORATORIES INC	813	I11-002826	\$ 82.00
5210-31-553-43590	214116	ENERGY LABORATORIES INC	813	I11-002827	\$ 82.00
5210-31-553-43590	214116	ENERGY LABORATORIES INC	813	I11-002828	\$ 82.00

City of Great Falls

Check Details Report (Date: 04/27/2011)

Account#	Check#	VendorName	Vendor#	Invoice#	Amount
5210-31-553-43590	214116	ENERGY LABORATORIES INC	813	I11-002829	\$ 132.00
5210-31-553-43590	214116	ENERGY LABORATORIES INC	813	I11-003099	\$ 82.00
5210-31-556-42290	214126	GENERAL DISTRIBUTING CO	65	I11-002905	\$ 44.95
5210-31-555-42220	214132	HAWKINS INC WATER	6715	I11-002831	\$ 896.00
5210-31-555-43690	214137	INDUSTRIAL AUTOMATION CONSULTING IN	6837	I11-003054	\$ 165.00
5210-31-555-43690	214137	INDUSTRIAL AUTOMATION CONSULTING IN	6837	I11-003056	\$ 2,344.25
5210-31-555-42290	214138	INDUSTRIAL TOWEL & COVER SUPPLY CO	104	I11-002840	\$ 30.53
5210-31-556-42290	214148	JOHNSON MADISON LUMBER INC	9	I11-002891	\$ 4.59
5210-00-000-21430	214151	KAPLAN, JEFFREY & TURANDOT	1679	I11-002913	\$ 96.10
5210-31-556-43620	214153	KENCO ENTERPRISES INC	7497	I11-002901	\$ 323.49
5210-31-553-42290	214166	MASTERCARD PROCESSING CENTER	8270	I11-002810	\$ -25.88
5210-31-555-42390	214167	MCNEESE DEB	12376	I11-002812	\$ 289.98
5210-31-555-43355	214179	MT DEPT OF ENVIRONMENTAL QUALITY	6565	I11-002841	\$ 30.00
5210-31-555-43355	214179	MT DEPT OF ENVIRONMENTAL QUALITY	6565	I11-002845	\$ 30.00
5210-31-555-43355	214179	MT DEPT OF ENVIRONMENTAL QUALITY	6565	I11-002876	\$ 30.00
5210-31-555-43355	214179	MT DEPT OF ENVIRONMENTAL QUALITY	6565	I11-002877	\$ 70.00
5210-31-555-43355	214179	MT DEPT OF ENVIRONMENTAL QUALITY	6565	I11-002878	\$ 30.00
5210-31-555-43355	214179	MT DEPT OF ENVIRONMENTAL QUALITY	6565	I11-002879	\$ 30.00
5210-31-555-43355	214179	MT DEPT OF ENVIRONMENTAL QUALITY	6565	I11-002880	\$ 30.00
5210-31-555-43355	214179	MT DEPT OF ENVIRONMENTAL QUALITY	6565	I11-002881	\$ 30.00
5210-31-555-43355	214179	MT DEPT OF ENVIRONMENTAL QUALITY	6565	I11-002882	\$ 30.00
5210-31-556-43350	214179	MT DEPT OF ENVIRONMENTAL QUALITY	6565	I11-002946	\$ 30.00
5210-31-556-43350	214179	MT DEPT OF ENVIRONMENTAL QUALITY	6565	I11-002949	\$ 30.00
5210-31-556-43350	214179	MT DEPT OF ENVIRONMENTAL QUALITY	6565	I11-002970	\$ 30.00
5210-31-556-43350	214179	MT DEPT OF ENVIRONMENTAL QUALITY	6565	I11-002971	\$ 30.00
5210-31-556-43350	214179	MT DEPT OF ENVIRONMENTAL QUALITY	6565	I11-002972	\$ 30.00
5210-31-556-43350	214179	MT DEPT OF ENVIRONMENTAL QUALITY	6565	I11-002974	\$ 30.00
5210-31-553-43590	214180	MT DEPT OF PUBLIC HEALTH & HUMAN	6874	I11-002824	\$ 231.00
5210-31-555-42290	214184	NATIONAL LAUNDRY	388	I11-003116	\$ 121.11

City of Great Falls

Check Details Report (Date: 04/27/2011)

Account#	Check#	VendorName	Vendor#	Invoice#	Amount
5210-31-556-42290	214189	NORTHWEST PIPE FITTINGS INC	142	I11-002892	\$ 39.51
5210-31-556-42370	214189	NORTHWEST PIPE FITTINGS INC	142	I11-002894	\$ 259.80
5210-31-556-42410	214189	NORTHWEST PIPE FITTINGS INC	142	I11-002900	\$ 17.60
5210-31-555-42390	214189	NORTHWEST PIPE FITTINGS INC	142	I11-003120	\$ 50.70
5210-31-555-42390	214189	NORTHWEST PIPE FITTINGS INC	142	I11-003122	\$ 87.96
5210-31-555-42330	214189	NORTHWEST PIPE FITTINGS INC	142	I11-003123	\$ 3,600.00
5210-31-555-43420	214190	NORTHWESTERN ENERGY	82	I11-002931	\$ 51.00
5210-31-553-42290	214195	PETTY CASH/DEB MCNEESE	13558	I11-003018	\$ 13.01
5210-31-555-43110	214195	PETTY CASH/DEB MCNEESE	13558	I11-003018	\$ 7.17
5210-31-553-43110	214195	PETTY CASH/DEB MCNEESE	13558	I11-003018	\$ 1.90
5210-31-555-42290	214195	PETTY CASH/DEB MCNEESE	13558	I11-003018	\$ 12.50
5210-31-555-42410	214201	PROBUILD	25	I11-002883	\$ 181.61
5210-31-555-43410	214203	QWEST	81	I11-002884	\$ 192.44
5210-00-000-21430	214217	SECRETARY OF VETERANS AFFAIR	1679	I11-002912	\$ 6.32
5210-31-555-42290	214223	SMITH EQUIPMENT CO	2317	I11-003127	\$ 35.00
5210-31-555-42390	214224	STEEL ETC	9522	I11-002885	\$ 4.60
5210-31-555-42390	214224	STEEL ETC	9522	I11-002886	\$ 24.50
5210-31-555-42410	214233	TOOL BOX INC	2886	I11-002887	\$ 31.70
5210-31-556-43412	214238	UTILITIES UNDERGROUND LOCATION CTR	3566	I11-002898	\$ 307.22

4001-31-511-49310	213898	A T KLEMENS INC	84	Fund(5210) Total I11-002475	\$23,712.41 \$ 26,444.04
4001-31-511-49310	213999	MT DEPT OF REVENUE 1% WITHHOLDING	136	I11-002476	\$ 267.11

5010-64-653-42350	213945	DOORS & HARDWARE UNLIMITED INC	6731	Fund(4001) Total I11-002662	\$26,711.15 \$ 88.00
5010-64-653-42350	213950	FERGUSON ENTERPRISES INC #3201	8915	I11-002663	\$ 100.62
5010-64-653-42290	214001	NATIONAL LAUNDRY	388	I11-002640	\$ 89.99
5010-64-651-42350	214017	QUALITY CARPET SERVICE INC	4437	I11-002608	\$ 275.00
5010-64-653-42350	214017	QUALITY CARPET SERVICE INC	4437	I11-002619	\$ 400.00
5010-64-654-42290	214020	RESPOND SYSTEMS	7214	I11-002571	\$ 96.54
5010-64-653-42290	214020	RESPOND SYSTEMS	7214	I11-002635	\$ 36.34

City of Great Falls

Check Details Report (Date: 04/27/2011)

Account#	Check#	VendorName	Vendor#	Invoice#	Amount
5010-16-513-49410	214036	STRAY MOOSE PRODUCTIONS	11547	I11-002589	\$ 35,000.00
5010-64-654-42210	214063	ACE HARDWARE	4876	I11-002701	\$ 7.49
5010-64-653-42350	214063	ACE HARDWARE	4876	I11-002719	\$ 26.96
5010-64-654-42330	214063	ACE HARDWARE	4876	I11-002721	\$ 17.06
5010-64-654-42210	214085	BIG R STORES (CSWW INC)	40	I11-002698	\$ 26.34
5010-64-654-42290	214085	BIG R STORES (CSWW INC)	40	I11-002703	\$ 19.35
5010-64-652-42290	214085	BIG R STORES (CSWW INC)	40	I11-002708	\$ 40.88
5010-64-653-42350	214100	COLUMBIA PAINT & COATINGS	50	I11-002736	\$ 34.47
5010-64-653-42350	214100	COLUMBIA PAINT & COATINGS	50	I11-002740	\$ 142.16
5010-00-000-15121	214122	FOOTJOY	12664	I11-000651	\$ -628.80
5010-00-000-15121	214122	FOOTJOY	12664	I11-000652	\$ 3.00
5010-00-000-15121	214122	FOOTJOY	12664	I11-002188	\$ 44.52
5010-00-000-15121	214122	FOOTJOY	12664	I11-002756	\$ 4,191.68
5010-00-000-15121	214124	GEAR FOR SPORTS INC (GFSI)	13281	I11-002754	\$ 1,001.06
5010-64-653-42350	214148	JOHNSON MADISON LUMBER INC	9	I11-002695	\$ 5.55
5010-64-653-42350	214148	JOHNSON MADISON LUMBER INC	9	I11-002713	\$ 28.38
5010-64-653-42230	214165	MASCO JANITORIAL SUPPLY	198	I11-002712	\$ 44.00
5010-64-651-43410	214173	MOUNTAIN CHIME TELEPHONE INC	1065	I11-002705	\$ 85.00
5010-00-000-15121	214187	NIKE USA INC	12676	I11-002755	\$ 375.00
5010-64-651-42290	214187	NIKE USA INC	12676	I11-002860	\$ 2,250.00
5010-64-653-42290	214187	NIKE USA INC	12676	I11-002860	\$ 2,250.00
5010-64-654-43420	214190	NORTHWESTERN ENERGY	82	I11-002931	\$ 9.76
5010-64-654-42290	214201	PROBUILD	25	I11-002696	\$ 7.97
5010-64-652-42290	214201	PROBUILD	25	I11-002710	\$ 39.11
5010-64-654-42330	214230	TIRE FACTORY	9864	I11-002694	\$ 12.00

6065-15-211-43530	0	BASIN CREEK POWER SERVICES LLC	13553	Fund(5010) Total I11-002492	\$46,119.43 \$ 10,000.00
6065-15-261-42130	213938	COMSTOR INFORMATION MANAGEMENT INC	10173	I11-002636	\$ 77.85
6065-15-262-42130	213938	COMSTOR INFORMATION MANAGEMENT INC	10173	I11-002636	\$ 92.85

City of Great Falls

Check Details Report (Date: 04/27/2011)

Account#	Check#	VendorName	Vendor#	Invoice#	Amount
6065-15-264-43210	213959	GREAT FALLS TRIBUNE	77	I11-002422	\$ 387.70
6065-15-268-43110	213969	INNOVATIVE POSTAL SERVICE INC	7796	I11-002432	\$ 107.21
6065-15-268-43110	213969	INNOVATIVE POSTAL SERVICE INC	7796	I11-002433	\$ 113.41
6065-15-268-43110	213969	INNOVATIVE POSTAL SERVICE INC	7796	I11-002434	\$ 146.42
6065-15-268-43110	213969	INNOVATIVE POSTAL SERVICE INC	7796	I11-002435	\$ 73.56
6065-15-268-43110	213969	INNOVATIVE POSTAL SERVICE INC	7796	I11-002437	\$ 84.90
6065-15-264-43110	213969	INNOVATIVE POSTAL SERVICE INC	7796	I11-002438	\$ 20.13
6065-15-264-43210	213969	INNOVATIVE POSTAL SERVICE INC	7796	I11-002438	\$ 12.44
6065-15-262-43590	213981	LIUNA NATIONAL (INDUSTRIAL)	4248	I11-002591	\$ 22.83
6065-15-262-43590	213981	LIUNA NATIONAL (INDUSTRIAL)	4248	I11-002592	\$ 2.15
6065-00-000-21400	214008	ONLINE RESOUCES CORPORATION	13523	I11-002590	\$ 50.00
6065-15-211-42190	214013	PICKWICK'S OFFICE WORKS INC	367	I11-002427	\$ 156.88
6065-15-261-42190	214013	PICKWICK'S OFFICE WORKS INC	367	I11-002427	\$ 261.11
6065-15-262-42190	214013	PICKWICK'S OFFICE WORKS INC	367	I11-002427	\$ 52.66
6065-15-263-42190	214013	PICKWICK'S OFFICE WORKS INC	367	I11-002427	\$ 104.22
6065-15-264-42190	214013	PICKWICK'S OFFICE WORKS INC	367	I11-002427	\$ 469.55
6065-15-261-42110	214013	PICKWICK'S OFFICE WORKS INC	367	I11-002427	\$ 124.35
6065-15-261-42110	214013	PICKWICK'S OFFICE WORKS INC	367	I11-002427	\$ 124.35
6065-15-264-43110	214140	INNOVATIVE POSTAL SERVICE INC	7796	I11-002943	\$ 13.53
6065-15-264-43210	214140	INNOVATIVE POSTAL SERVICE INC	7796	I11-002943	\$ 3.85
6065-15-264-43110	214140	INNOVATIVE POSTAL SERVICE INC	7796	I11-002944	\$ 1,757.03
6065-15-264-43210	214140	INNOVATIVE POSTAL SERVICE INC	7796	I11-002944	\$ 587.99
6065-15-264-43110	214140	INNOVATIVE POSTAL SERVICE INC	7796	I11-002945	\$ 144.48
6065-15-264-43210	214140	INNOVATIVE POSTAL SERVICE INC	7796	I11-002945	\$ 18.48
6065-15-264-43110	214140	INNOVATIVE POSTAL SERVICE INC	7796	I11-002947	\$ 197.80
6065-15-264-43210	214140	INNOVATIVE POSTAL SERVICE INC	7796	I11-002947	\$ 25.30
6065-15-268-43110	214140	INNOVATIVE POSTAL SERVICE INC	7796	I11-002948	\$ 107.92
6065-15-268-43110	214140	INNOVATIVE POSTAL SERVICE INC	7796	I11-002951	\$ 94.91
6065-15-268-43110	214140	INNOVATIVE POSTAL SERVICE INC	7796	I11-002953	\$ 112.62
6065-15-268-43110	214140	INNOVATIVE POSTAL SERVICE INC	7796	I11-002954	\$ 54.90

City of Great Falls

Check Details Report (Date: 04/27/2011)

Account#	Check#	VendorName	Vendor#	Invoice#	Amount
6065-15-268-43110	214140	INNOVATIVE POSTAL SERVICE INC	7796	I11-002956	\$ 74.03
6065-15-264-42110	214198	PICKWICK'S OFFICE WORKS INC	367	I11-002853	\$ 7.99
6065-15-211-42190	214198	PICKWICK'S OFFICE WORKS INC	367	I11-002942	\$ 35.61
6065-15-261-42190	214198	PICKWICK'S OFFICE WORKS INC	367	I11-002942	\$ 59.26
6065-15-262-42190	214198	PICKWICK'S OFFICE WORKS INC	367	I11-002942	\$ 11.95
6065-15-263-42190	214198	PICKWICK'S OFFICE WORKS INC	367	I11-002942	\$ 23.65
6065-15-263-42190	214198	PICKWICK'S OFFICE WORKS INC	367	I11-002942	\$ 106.57

2956-71-712-49310	214228	THOMAS DEAN & HOSKINS INC	119	Fund(6065) Total I11-003050	\$15,922.44 \$ 24,116.67

6060-21-151-43410	214018	QWEST	81	Fund(2956) Total I11-002659	\$24,116.67 \$ 677.15
6060-21-151-43410	214203	QWEST	81	I11-003000	\$ 250.26

2440-31-536-42390	213899	ACE HARDWARE	4876	Fund(6060) Total I11-002674	\$927.41 \$ 4.14

2525-15-211-42190	213943	Deborah Hanson	12645	Fund(2440) Total I11-002497	\$4.14 \$ 233.40

5740-64-691-42290	213908	BARBIZON LIGHT OF THE ROCKIES	10921	Fund(2525) Total I11-002671	\$233.40 \$ 74.95
5740-64-692-42290	213946	DOUBLE G ENGRAVING & AWARDS	5178	I11-002521	\$ 122.31
5740-00-000-21400	213958	GREAT FALLS SYMPHONY ASSOC INC	299	I11-002583	\$ 4,190.84
5740-64-692-43340	213959	GREAT FALLS TRIBUNE	77	I11-002621	\$ 1,115.75
5740-64-692-43340	214021	RIVERS EDGE PRINTING & DISTRIBUTION	13106	I11-002477	\$ 643.00
5740-00-000-21480	214022	Rocky Mountain Elk Foundation	12731	I11-002490	\$ 442.00
5740-64-691-42120	214053	VISION NET INC	11369	I11-002520	\$ 9,732.49
5740-64-691-34667	214125	GEMBERLING JOHN	6037	I11-003002	\$ 75.00
5740-64-691-34668	214235	TRIANGLE PIANO SERVICE	5189	I11-002995	\$ 90.00

2855-21-318-43950	213910	BEALL ROBERT	11644	Fund(5740) Total I11-002655	\$16,486.34 \$ 370.91
2855-21-391-42190	213939	COOL GUY GEAR LLC	13237	I11-002633	\$ 375.00
2855-21-324-43590	214160	LICINI PRINT SHOP INC	181	I11-003135	\$ 339.00

City of Great Falls

Check Details Report (Date: 04/27/2011)

Account#	Check#	VendorName	Vendor#	Invoice#	Amount
2855-21-318-43950	214166	MASTERCARD PROCESSING CENTER	8270	I11-002992	\$ 7.98
2855-21-318-43950	214166	MASTERCARD PROCESSING CENTER	8270	I11-002992	\$ 29.38
2855-21-318-43950	214166	MASTERCARD PROCESSING CENTER	8270	I11-002992	\$ 19.88
2855-21-324-43590	214216	SCHAFFER JOHN	8139	I11-002990	\$ 23.11
2855-21-324-43590	214216	SCHAFFER JOHN	8139	I11-002990	\$ 51.21
2855-21-324-43590	214216	SCHAFFER JOHN	8139	I11-002990	\$ 19.86
2855-21-318-43415	214240	VERIZON WIRELESS	10858	I11-003144	\$ 12.99

2850-21-313-43410	214203	QWEST	81	Fund(2855) Total I11-003024	\$1,249.32 \$ 632.10

2398-71-727-42290	214198	PICKWICK'S OFFICE WORKS INC	367	Fund(2850) Total I11-002553	\$632.10 \$ 31.20

2520-31-536-42430	213899	ACE HARDWARE	4876	Fund(2398) Total I11-002677	\$31.20 \$ 59.97
2520-31-536-42290	213915	BIG R STORES (CSWW INC)	40	I11-002676	\$ 24.95
2520-31-531-42290	213917	BIG SKY FIRE/AFFIRMED MEDICAL	2129	I11-002415	\$ 49.43
2520-31-536-42290	213935	COLUMBIA PAINT & COATINGS	50	I11-002675	\$ 40.77
2520-31-531-43560	213937	COMMUNITY HEALTH CARE CENTER	7277	I11-002673	\$ 66.00
2520-31-536-42430	213951	FLEET SUPPLY COMPANY	64	I11-002678	\$ 1.20
2520-31-536-42290	213968	INDUSTRIAL TOWEL & COVER SUPPLY CO	104	I11-002679	\$ 11.98
2520-31-536-42420	213982	Lordon Inc.	12649	I11-002291	\$ 440.55
2520-31-531-42290	213987	MICHAEL TODD & COMPANY INC	2223	I11-002439	\$ 379.21
2520-31-531-43630	214001	NATIONAL LAUNDRY	388	I11-002585	\$ 21.28
2520-31-536-42420	214003	NEWMAN SIGNS INC	2968	I11-002440	\$ 345.00
2520-31-531-42390	214004	NORMONT EQUIPMENT CO	15	I11-002672	\$ 600.00
2520-31-536-43420	214007	NORTHWESTERN ENERGY	82	I11-002647	\$ 28.52
2520-31-531-43735	214012	PETTY CASH/STRENDING DEE	420	I11-002745	\$ 55.89
2520-31-531-42190	214013	PICKWICK'S OFFICE WORKS INC	367	I11-002361	\$ 22.83
2520-31-536-42190	214013	PICKWICK'S OFFICE WORKS INC	367	I11-002361	\$ 22.83
2520-31-531-43410	214018	QWEST	81	I11-002486	\$ 56.66
2520-31-531-42410	214030	SHINING MOUNTAIN IMAGES INC	6767	I11-002587	\$ 1,289.40

City of Great Falls

Check Details Report (Date: 04/27/2011)

Account#	Check#	VendorName	Vendor#	Invoice#	Amount
2520-31-531-42390	214050	UNITED MATERIALS OF GREAT FALLS INC	121	I11-002441	\$ 4,947.99
2520-31-531-42390	214050	UNITED MATERIALS OF GREAT FALLS INC	121	I11-002680	\$ 4,846.49
2520-31-531-42390	214050	UNITED MATERIALS OF GREAT FALLS INC	121	I11-002681	\$ 5,327.75
2520-31-531-43410	214055	WCS TELECOM	11222	I11-002358	\$ 13.47
2520-31-536-43410	214055	WCS TELECOM	11222	I11-002358	\$ 10.86
2520-31-531-42290	214085	BIG R STORES (CSWW INC)	40	I11-003052	\$ 4.62
2520-31-536-42430	214101	CONSOLIDATED ELECTRICAL DIST INC	52	I11-002914	\$ 124.53
2520-31-531-42390	214135	HUSKY OIL MARKETING COMPANY	11038	I11-002436	\$ 8,798.43
2520-31-531-43420	214153	KENCO ENTERPRISES INC	7497	I11-002808	\$ 109.25
2520-31-536-43620	214173	MOUNTAIN CHIME TELEPHONE INC	1065	I11-002767	\$ 58.57
2520-31-531-43620	214173	MOUNTAIN CHIME TELEPHONE INC	1065	I11-002767	\$ 58.57
2520-31-536-42420	214186	NEWMAN SIGNS INC	2968	I11-002759	\$ 1,080.00
2520-31-531-43620	214189	NORTHWEST PIPE FITTINGS INC	142	I11-002852	\$ 2.59
2520-31-536-43420	214190	NORTHWESTERN ENERGY	82	I11-002931	\$ 308.23
2520-31-536-42190	214198	PICKWICK'S OFFICE WORKS INC	367	I11-002757	\$ 12.61
2520-31-531-42190	214198	PICKWICK'S OFFICE WORKS INC	367	I11-002757	\$ 12.62
2520-31-536-42190	214198	PICKWICK'S OFFICE WORKS INC	367	I11-002758	\$ 39.11
2520-31-531-42190	214198	PICKWICK'S OFFICE WORKS INC	367	I11-002758	\$ 39.12
2520-31-536-42190	214198	PICKWICK'S OFFICE WORKS INC	367	I11-002820	\$ 104.33
2520-31-531-43620	214198	PICKWICK'S OFFICE WORKS INC	367	I11-002820	\$ 104.33
2520-31-536-42190	214198	PICKWICK'S OFFICE WORKS INC	367	I11-002821	\$ 321.16
2520-31-531-43620	214198	PICKWICK'S OFFICE WORKS INC	367	I11-002821	\$ 321.16
2520-31-531-49310	214213	ROYAL HARPINE CONSTRUCTION	250	I11-002973	\$ 1,544.00
2520-31-536-42435	214219	SHERWIN WILLIAMS	29	I11-002917	\$ 3,200.00
2520-31-531-42290	214223	SMITH EQUIPMENT CO	2317	I11-002766	\$ 9.00
2520-31-531-43620	214224	STEEL ETC	9522	I11-002916	\$ 2,513.00
2520-31-531-42390	214237	UNITED MATERIALS OF GREAT FALLS INC	121	I11-002861	\$ 4,367.75
2520-31-531-42390	214237	UNITED MATERIALS OF GREAT FALLS INC	121	I11-002863	\$ 4,115.25
2520-31-531-42390	214237	UNITED MATERIALS OF GREAT FALLS INC	121	I11-002865	\$ 4,974.25
2520-31-531-42390	214237	UNITED MATERIALS OF GREAT FALLS INC	121	I11-002866	\$ 328.25

City of Great Falls

Check Details Report (Date: 04/27/2011)

Account#	Check#	VendorName	Vendor#	Invoice#	Amount
2520-31-536-42430	214246	WESTERN SYSTEMS INC	12526	I11-002915	\$ 1,440.00

				Fund(2520) Total	\$52,653.76
2220-61-611-43320	213904	AUDIOGO	5795	I11-002498	\$ 112.26
2220-61-611-43320	213909	BARNES & NOBLE BOOKSELLERS INC	5643	I11-002329	\$ 291.73
2220-61-611-42190	213917	BIG SKY FIRE/AFFIRMED MEDICAL	2129	I11-002239	\$ 51.30
2220-61-611-43320	213922	BRODART COMPANY	92	I11-002334	\$ 20.29
2220-61-611-43320	213922	BRODART COMPANY	92	I11-002335	\$ 63.45
2220-61-611-43320	213922	BRODART COMPANY	92	I11-002339	\$ 18.16
2220-61-611-43320	213922	BRODART COMPANY	92	I11-002340	\$ 108.59
2220-61-611-43320	213922	BRODART COMPANY	92	I11-002340	\$ 49.71
2220-61-611-43320	213922	BRODART COMPANY	92	I11-002341	\$ 16.47
2220-61-611-43320	213922	BRODART COMPANY	92	I11-002344	\$ 121.96
2220-61-611-43320	213922	BRODART COMPANY	92	I11-002502	\$ 29.28
2220-61-611-43320	213922	BRODART COMPANY	92	I11-002503	\$ 32.59
2220-61-611-43320	213922	BRODART COMPANY	92	I11-002504	\$ 74.36
2220-61-611-43320	213922	BRODART COMPANY	92	I11-002505	\$ 21.36
2220-61-611-43320	213922	BRODART COMPANY	92	I11-002509	\$ 56.94
2220-61-611-43320	213922	BRODART COMPANY	92	I11-002510	\$ 18.00
2220-61-611-43320	213922	BRODART COMPANY	92	I11-002511	\$ 34.72
2220-61-611-43320	213922	BRODART COMPANY	92	I11-002513	\$ 29.99
2220-61-611-42390	213931	CHEMSEARCH DIVISION	1903	I11-002244	\$ 204.55
2220-61-611-43320	213947	EBSCO INDUSTRIES INC	931	I11-002499	\$ 5,986.49
2220-61-611-43320	213947	EBSCO INDUSTRIES INC	931	I11-002500	\$ 16.37
2220-61-611-43320	213947	EBSCO INDUSTRIES INC	931	I11-002501	\$ -192.00
2220-61-611-43320	213979	Language Lizard LLC	12978	I11-002332	\$ 118.65
2220-61-611-43320	213980	LIBRARY JOURNAL	4213	I11-002333	\$ 157.99
2220-61-611-42390	214001	NATIONAL LAUNDRY	388	I11-002243	\$ 17.25
2220-61-611-42120	214016	PROPERTY & SUPPLY BUREAU ST OF MT	621	I11-002242	\$ 362.70
2220-61-611-42190	214016	PROPERTY & SUPPLY BUREAU ST OF MT	621	I11-002242	\$ 55.88
2220-61-611-43412	214033	SOFTWORX INC	5124	I11-002240	\$ 188.00

City of Great Falls

Check Details Report (Date: 04/27/2011)

Account#	Check#	VendorName	Vendor#	Invoice#	Amount
2220-61-611-42390	214063	ACE HARDWARE	4876	I11-002928	\$ 30.43
2220-61-611-43320	214066	AMAZON.COM	10702	I11-002709	\$ 16.47
2220-61-611-43320	214066	AMAZON.COM	10702	I11-002711	\$ 24.06
2220-61-611-43320	214066	AMAZON.COM	10702	I11-002715	\$ 20.86
2220-61-611-43320	214066	AMAZON.COM	10702	I11-002716	\$ 139.92
2220-61-611-43320	214066	AMAZON.COM	10702	I11-002717	\$ 14.99
2220-61-611-43320	214066	AMAZON.COM	10702	I11-002720	\$ 59.44
2220-61-611-45920	214073	April Molen	12978	I11-002308	\$ 17.95
2220-61-611-43630	214088	BLACK BOX NETWORK SERVICES	11628	I11-002930	\$ 1,156.00
2220-61-611-43320	214095	BRODART COMPANY	92	I11-002723	\$ 10.87
2220-61-611-43320	214095	BRODART COMPANY	92	I11-002725	\$ 13.90
2220-61-611-43320	214095	BRODART COMPANY	92	I11-002726	\$ 75.78
2220-61-611-43320	214095	BRODART COMPANY	92	I11-002731	\$ 36.63
2220-61-611-43320	214095	BRODART COMPANY	92	I11-003038	\$ 133.24
2220-61-611-43320	214095	BRODART COMPANY	92	I11-003040	\$ 55.19
2220-61-611-43320	214095	BRODART COMPANY	92	I11-003041	\$ 59.67
2220-61-611-43320	214095	BRODART COMPANY	92	I11-003045	\$ 13.73
2220-61-611-43320	214119	FAMILY CHRISTIAN STORES INC	4216	I11-003046	\$ 76.46
2220-61-611-45920	214128	Gladys Rayhill	12978	I11-002925	\$ 12.95
2220-61-611-43420	214190	NORTHWESTERN ENERGY	82	I11-002931	\$ 41.46
2220-61-611-42190	214196	PETTY CASH/LIBRARY	97	I11-002305	\$ 5.49
2220-61-611-48130	214196	PETTY CASH/LIBRARY	97	I11-002305	\$ 205.62
2220-61-611-43350	214196	PETTY CASH/LIBRARY	97	I11-002305	\$ 70.00
2220-61-611-43630	214199	PITNEY BOWES INC	280	I11-002924	\$ 447.00
2220-61-611-43320	214202	Pulsing Earth Media	12978	I11-002722	\$ 24.95
2220-61-611-43320	214227	THOMAS BOUREGY & CO INC	8263	I11-003047	\$ 34.40
2220-61-611-43526	214236	UNIQUE MANAGEMENT SERVICES INC	8996	I11-002932	\$ 187.95
2394-71-728-43790	213984	MASTERCARD PROCESSING CENTER	8270	I11-002279	\$ 346.40
2394-71-728-43390	213990	MONTANA INTERACTIVE LLC	12485	I11-002226	\$ 33.75
				----- Fund(2220) Total	\$11,052.45

City of Great Falls

Check Details Report (Date: 04/27/2011)

Account#	Check#	VendorName	Vendor#	Invoice#	Amount
2394-71-728-43790	214029	SHEETS CHARLES	3781	I11-002289	\$ 280.80
2394-71-728-43590	214035	STEWART TITLE COMPANY GF DIVISION	263	I11-002269	\$ 110.00
2394-71-728-42290	214173	MOUNTAIN CHIME TELEPHONE INC	1065	I11-002485	\$ 85.00
2394-71-012-32310	214185	NEIGHBORWORKS GREAT FALLS	530	I11-002612	\$ 369.00
2394-71-728-42290	214198	PICKWICK'S OFFICE WORKS INC	367	I11-002553	\$ 10.20
2394-71-728-42290	214198	PICKWICK'S OFFICE WORKS INC	367	I11-002564	\$ 46.50
2394-71-728-42290	214198	PICKWICK'S OFFICE WORKS INC	367	I11-002565	\$ 40.28
2394-71-728-43790	214205	REID LARRY	13379	I11-002685	\$ 34.80
2394-71-728-43590	214225	STEWART TITLE COMPANY GF DIVISION	263	I11-003016	\$ 110.00

					Fund(2394) Total\$1,466.73
2221-61-613-43320	213909	BARNES & NOBLE BOOKSELLERS INC	5643	I11-002328	\$ -121.48
2221-61-613-43320	213909	BARNES & NOBLE BOOKSELLERS INC	5643	I11-002329	\$ 9.56
2221-61-613-43320	213909	BARNES & NOBLE BOOKSELLERS INC	5643	I11-002329	\$ 70.29
2221-61-613-43320	213909	BARNES & NOBLE BOOKSELLERS INC	5643	I11-002330	\$ 338.75
2221-61-613-43320	213909	BARNES & NOBLE BOOKSELLERS INC	5643	I11-002330	\$ 43.97
2221-61-613-43320	213909	BARNES & NOBLE BOOKSELLERS INC	5643	I11-002331	\$ 83.86
2221-61-613-43320	213922	BRODART COMPANY	92	I11-002334	\$ 257.18
2221-61-613-43320	213922	BRODART COMPANY	92	I11-002334	\$ 33.41
2221-61-613-43320	213922	BRODART COMPANY	92	I11-002335	\$ 182.25
2221-61-613-43320	213922	BRODART COMPANY	92	I11-002336	\$ 205.36
2221-61-613-43320	213922	BRODART COMPANY	92	I11-002340	\$ 212.87
2221-61-613-43320	213922	BRODART COMPANY	92	I11-002341	\$ 20.91
2221-61-613-43320	213922	BRODART COMPANY	92	I11-002341	\$ 202.50
2221-61-613-43320	213922	BRODART COMPANY	92	I11-002502	\$ 16.89
2221-61-613-43320	213922	BRODART COMPANY	92	I11-002503	\$ 154.62
2221-61-613-43320	213922	BRODART COMPANY	92	I11-002504	\$ 22.80
2221-61-613-43320	213922	BRODART COMPANY	92	I11-002507	\$ 40.73
2221-61-613-43320	213922	BRODART COMPANY	92	I11-002508	\$ 32.00
2221-61-613-43320	213922	BRODART COMPANY	92	I11-002512	\$ 76.05
2221-61-613-43320	213922	BRODART COMPANY	92	I11-002513	\$ 69.39

City of Great Falls

Check Details Report (Date: 04/27/2011)

Account#	Check#	VendorName	Vendor#	Invoice#	Amount
2221-61-613-43320	213947	EBSCO INDUSTRIES INC	931	I11-002499	\$ 109.00
2221-61-613-43320	213979	Language Lizard LLC	12978	I11-002332	\$ 256.25
2221-61-613-43320	214066	AMAZON.COM	10702	I11-002709	\$ 44.49
2221-61-613-43320	214066	AMAZON.COM	10702	I11-002711	\$ 20.35
2221-61-613-43320	214066	AMAZON.COM	10702	I11-002714	\$ 12.05
2221-61-613-43320	214066	AMAZON.COM	10702	I11-002718	\$ 19.77
2221-61-613-43320	214066	AMAZON.COM	10702	I11-002720	\$ 21.25
2221-61-613-43320	214066	AMAZON.COM	10702	I11-002720	\$ 23.78
2221-61-613-43320	214076	BAKER & TAYLOR INC	4335	I11-003048	\$ 59.06
2221-61-613-43320	214095	BRODART COMPANY	92	I11-002725	\$ 21.79
2221-61-613-43320	214095	BRODART COMPANY	92	I11-002726	\$ 345.86
2221-61-613-43320	214095	BRODART COMPANY	92	I11-002731	\$ 219.24
2221-61-613-43320	214095	BRODART COMPANY	92	I11-003038	\$ 243.81
2221-61-613-43320	214095	BRODART COMPANY	92	I11-003039	\$ 922.90
2221-61-613-43320	214095	BRODART COMPANY	92	I11-003040	\$ 41.95
2221-61-613-43320	214095	BRODART COMPANY	92	I11-003041	\$ 54.26
2221-61-613-43320	214095	BRODART COMPANY	92	I11-003042	\$ 35.34
2221-61-613-43320	214095	BRODART COMPANY	92	I11-003043	\$ 39.06
2221-61-613-43320	214095	BRODART COMPANY	92	I11-003044	\$ 22.82
2221-61-613-43945	214113	EASTER SEALS/GOODWILL NORTHERN ROCK	4028	I11-002926	\$ 34.20
2221-61-613-43945	214130	GREAT FALLS TRIBUNE	77	I11-002927	\$ 300.00
2221-61-613-42120	214191	OFFICE CENTER INC (THE)	2499	I11-002929	\$ 602.00
2221-61-613-43945	214196	PETTY CASH/LIBRARY	97	I11-002305	\$ 34.38

6070-31-521-42290	213940	CRESCENT ELECTRIC SUPPLY CO	405	I11-002391	\$ 79.44
6070-31-521-42290	213941	CULLIGAN WATER CONDITIONING	2193	I11-002429	\$ 9.00
6070-31-521-43630	214001	NATIONAL LAUNDRY	388	I11-002586	\$ 19.25
6070-31-521-42190	214012	PETTY CASH/STRENDING DEE	420	I11-002745	\$ 23.86
6070-31-521-42190	214013	PICKWICK'S OFFICE WORKS INC	367	I11-002642	\$ 41.33
					Fund(2221) Total \$5,435.52

City of Great Falls

Check Details Report (Date: 04/27/2011)

Account#	Check#	VendorName	Vendor#	Invoice#	Amount
6070-31-521-43410	214055	WCS TELECOM	11222	I11-002358	\$ 17.60
6070-31-521-42190	214063	ACE HARDWARE	4876	I11-002976	\$ 33.98
6070-31-521-42120	214166	MASTERCARD PROCESSING CENTER	8270	I11-002977	\$ 235.45
6070-31-521-43390	214188	NOAA NATIONAL DATA CENTER	8132	I11-002975	\$ 34.00
6070-31-521-42290	214198	PICKWICK'S OFFICE WORKS INC	367	I11-002757	\$ 25.23
6070-31-521-42290	214198	PICKWICK'S OFFICE WORKS INC	367	I11-002758	\$ 22.50

Fund(6070) Total					\$541.64
5410-31-585-42290	213917	BIG SKY FIRE/AFFIRMED MEDICAL	2129	I11-002415	\$ 60.47
5410-31-585-43560	213930	CHEMNET CONSORTIUM INC (THE)	11998	I11-002469	\$ 49.50
5410-31-584-43445	213993	MONTANA WASTE SYSTEMS INC	8467	I11-002323	\$ 22,792.65
5410-31-585-43445	213993	MONTANA WASTE SYSTEMS INC	8467	I11-002323	\$ 33,319.26
5410-31-588-43445	213993	MONTANA WASTE SYSTEMS INC	8467	I11-002323	\$ 3,811.15
5410-31-584-43630	214001	NATIONAL LAUNDRY	388	I11-002585	\$ 10.64
5410-31-585-43630	214001	NATIONAL LAUNDRY	388	I11-002585	\$ 10.65
5410-31-585-42190	214013	PICKWICK'S OFFICE WORKS INC	367	I11-002361	\$ 22.83
5410-31-584-42190	214013	PICKWICK'S OFFICE WORKS INC	367	I11-002361	\$ 22.83
5410-31-585-42190	214013	PICKWICK'S OFFICE WORKS INC	367	I11-002466	\$ 3.39
5410-31-584-42190	214013	PICKWICK'S OFFICE WORKS INC	367	I11-002466	\$ 3.40
5410-31-588-43410	214018	QWEST	81	I11-002495	\$ 43.16
5410-31-585-42290	214030	SHINING MOUNTAIN IMAGES INC	6767	I11-002587	\$ 130.95
5410-31-584-42290	214030	SHINING MOUNTAIN IMAGES INC	6767	I11-002587	\$ 130.95
5410-31-584-49410	214034	SOLID WASTE SYSTEMS INC	6969	I11-002454	\$ 24,886.00
5410-31-585-49410	214034	SOLID WASTE SYSTEMS INC	6969	I11-002454	\$ 16,964.00
5410-31-584-43410	214055	WCS TELECOM	11222	I11-002358	\$ 2.98
5410-31-585-43410	214055	WCS TELECOM	11222	I11-002358	\$ 2.99
5410-31-588-43410	214055	WCS TELECOM	11222	I11-002358	\$ 0.66
5410-31-585-43620	214153	KENCO ENTERPRISES INC	7497	I11-002808	\$ 54.62
5410-31-585-43620	214153	KENCO ENTERPRISES INC	7497	I11-002808	\$ 54.62
5410-31-584-43620	214173	MOUNTAIN CHIME TELEPHONE INC	1065	I11-002767	\$ 58.57
5410-31-585-43620	214173	MOUNTAIN CHIME TELEPHONE INC	1065	I11-002767	\$ 58.57

City of Great Falls

Check Details Report (Date: 04/27/2011)

Account#	Check#	VendorName	Vendor#	Invoice#	Amount
5410-31-588-43420	214190	NORTHWESTERN ENERGY	82	I11-002931	\$ 14.18
5410-31-584-42290	214198	PICKWICK'S OFFICE WORKS INC	367	I11-002757	\$ 12.61
5410-31-585-42290	214198	PICKWICK'S OFFICE WORKS INC	367	I11-002757	\$ 12.62
5410-31-584-42190	214198	PICKWICK'S OFFICE WORKS INC	367	I11-002758	\$ 39.12
5410-31-585-42190	214198	PICKWICK'S OFFICE WORKS INC	367	I11-002758	\$ 39.12
5410-31-584-43620	214198	PICKWICK'S OFFICE WORKS INC	367	I11-002820	\$ 88.68
5410-31-588-43620	214198	PICKWICK'S OFFICE WORKS INC	367	I11-002820	\$ 31.30
5410-31-585-43620	214198	PICKWICK'S OFFICE WORKS INC	367	I11-002820	\$ 88.68
5410-31-584-43620	214198	PICKWICK'S OFFICE WORKS INC	367	I11-002821	\$ 275.26
5410-31-588-43620	214198	PICKWICK'S OFFICE WORKS INC	367	I11-002821	\$ 97.80
5410-31-585-43620	214198	PICKWICK'S OFFICE WORKS INC	367	I11-002821	\$ 275.26
5410-31-588-43390	214229	TILLERAAS LANDSCAPE NURSERY	3355	I11-003053	\$ 131.00

6075-31-511-43110	214012	PETTY CASH/STRENDING DEE	420	Fund(5410) Total I11-002745	\$103,600.47 \$ 6.15
6075-31-511-43410	214055	WCS TELECOM	11222	I11-002358	\$ 31.06
6075-31-511-43410	214203	QWEST	81	I11-002897	\$ 43.16
6075-31-511-42210	214229	TILLERAAS LANDSCAPE NURSERY	3355	I11-003053	\$ 245.00

5720-21-313-43590	213997	MT DEPT OF ADMINISTRATION INFO	6100	Fund(6075) Total I11-002688	\$325.37 \$ 177.00
5720-21-313-43417	214018	QWEST	81	I11-002657	\$ 292.47
5720-21-313-43417	214018	QWEST	81	I11-002658	\$ 91.30
5720-21-313-43417	214018	QWEST	81	I11-002660	\$ 94.95
5720-21-313-43417	214018	QWEST	81	I11-002661	\$ 45.66
5720-21-313-43417	214018	QWEST	81	I11-002664	\$ 119.32
5720-21-313-43417	214018	QWEST	81	I11-002665	\$ 119.32
5720-21-313-43417	214018	QWEST	81	I11-002666	\$ 119.32
5720-21-313-43417	214018	QWEST	81	I11-002667	\$ 119.32
5720-21-313-43417	214018	QWEST	81	I11-002668	\$ 45.66
5720-21-313-43417	214018	QWEST	81	I11-002669	\$ 45.66
5720-21-313-43417	214018	QWEST	81	I11-002686	\$ 28.54

City of Great Falls

Check Details Report (Date: 04/27/2011)

Account#	Check#	VendorName	Vendor#	Invoice#	Amount
5720-21-313-43417	214018	QWEST	81	I11-002687	\$ 155.65
5720-21-313-42290	214198	PICKWICK'S OFFICE WORKS INC	367	I11-003014	\$ 159.98
5720-21-313-42290	214198	PICKWICK'S OFFICE WORKS INC	367	I11-003017	\$ -79.99
5720-21-313-43417	214203	QWEST	81	I11-003025	\$ 5,850.26
5720-21-313-43417	214203	QWEST	81	I11-003027	\$ 43.16
5720-21-313-43417	214203	QWEST	81	I11-003028	\$ 86.32
5720-21-313-43417	214203	QWEST	81	I11-003029	\$ 31.54
5720-21-313-43417	214203	QWEST	81	I11-003030	\$ 51.85

5725-71-725-43410	214018	QWEST	81	I11-002483	\$ 47.47
					Fund(5720) Total\$7,597.29
5725-71-725-43690	214062	A TO Z LOCK & KEY	1849	I11-003010	\$ 106.90
5725-71-725-42290	214069	AMSAN	47	I11-002872	\$ 46.00
5725-71-725-43590	214072	APCOA/STANDARD PARKING	374	I11-002867	\$ 25,339.82
5725-71-725-43690	214074	AUTOMATED MERCHANT SYSTEMS INC	12632	I11-003011	\$ 195.00
5725-71-725-43210	214140	INNOVATIVE POSTAL SERVICE INC	7796	I11-002873	\$ 221.34
5725-71-725-43590	214154	KONE INC	8920	I11-002870	\$ 658.02
5725-71-725-43420	214190	NORTHWESTERN ENERGY	82	I11-002931	\$ 102.02
5725-71-725-42190	214198	PICKWICK'S OFFICE WORKS INC	367	I11-002553	\$ 52.31
5725-71-725-42290	214201	PROBUILD	25	I11-003008	\$ 0.89
5725-71-725-42290	214201	PROBUILD	25	I11-003009	\$ 27.95
5725-71-725-43690	214221	SIGNATURE CONTROL SYSTEMS LLC	12316	I11-002875	\$ 443.00
5725-71-725-42290	214245	WESTERN SIGN	2645	I11-002874	\$ 55.00

2940-71-742-43590	213957	GREAT FALLS LUMBER	3486	I11-002342	\$ 366.22
					Fund(5725) Total\$27,295.72
2940-71-742-47330	213959	GREAT FALLS TRIBUNE	77	I11-002422	\$ 483.80
2940-71-742-47330	214010	PARIS GIBSON SQUARE INC	4590	I11-002277	\$ 1,463.78
2940-71-742-43590	214015	PROBUILD BLOCK GRANT	310	I11-001918	\$ 29.81
2940-71-742-43590	214147	JOHNSON MADISON LUMBER (BLOCK	1578	I11-002539	\$ 28.97
2940-71-742-43590	214147	JOHNSON MADISON LUMBER (BLOCK	1578	I11-002551	\$ 63.96
2940-71-742-43590	214147	JOHNSON MADISON LUMBER (BLOCK	1578	I11-002555	\$ 25.25

City of Great Falls

Check Details Report (Date: 04/27/2011)

Account#	Check#	VendorName	Vendor#	Invoice#	Amount
2940-71-742-43590	214147	JOHNSON MADISON LUMBER (BLOCK	1578	I11-002559	\$ 1,166.10
2940-71-742-43590	214147	JOHNSON MADISON LUMBER (BLOCK	1578	I11-002560	\$ 858.07
2940-71-742-43590	214147	JOHNSON MADISON LUMBER (BLOCK	1578	I11-002563	\$ 178.36
2940-71-742-43590	214147	JOHNSON MADISON LUMBER (BLOCK	1578	I11-002566	\$ 116.78
2940-71-742-43590	214147	JOHNSON MADISON LUMBER (BLOCK	1578	I11-002568	\$ 128.30
2940-71-742-43590	214147	JOHNSON MADISON LUMBER (BLOCK	1578	I11-002576	\$ 36.00
2940-71-742-43590	214147	JOHNSON MADISON LUMBER (BLOCK	1578	I11-002578	\$ 234.83
2940-71-742-43590	214147	JOHNSON MADISON LUMBER (BLOCK	1578	I11-002579	\$ 58.82
2940-71-742-43590	214147	JOHNSON MADISON LUMBER (BLOCK	1578	I11-002580	\$ 232.52
2940-71-742-43590	214147	JOHNSON MADISON LUMBER (BLOCK	1578	I11-002581	\$ 120.48
2940-71-742-43590	214147	JOHNSON MADISON LUMBER (BLOCK	1578	I11-002582	\$ 51.59
2940-71-742-49310	214156	L'HEUREUX PAGE WERNER PC	2986	I11-002682	\$ 543.76
2940-71-742-47330	214210	ROBINSON CONSTRUCTION CO	13545	I11-002825	\$ 318.11

				Fund(2940) Total	\$6,505.51
5730-64-642-43940	213901	Amber Koesling	12646	I11-002637	\$ 75.00
5730-64-662-42230	213983	MASCO JANITORIAL SUPPLY	198	I11-002514	\$ 60.65
5730-64-642-47420	213984	MASTERCARD PROCESSING CENTER	8270	I11-002094	\$ 46.00
5730-64-662-42230	214001	NATIONAL LAUNDRY	388	I11-002420	\$ 29.74
5730-64-662-43410	214018	QWEST	81	I11-002431	\$ 129.24
5730-64-642-43210	214087	BIG SKY IMPRINTS	5262	I11-002893	\$ 115.88
5730-64-642-47420	214111	DOUBLE G ENGRAVING & AWARDS	5178	I11-002823	\$ 620.00
5730-64-662-43590	214131	HAUER FAMILY SKATING CENTER	12077	I11-002700	\$ 60.00
5730-64-662-43590	214141	J & V RESTAURANT & FIRE SUPPLY	6109	I11-002838	\$ 1,035.70
5730-64-642-43940	214146	JOHNSON BROTHERS LIGHTS AND SOUND	895	I11-002746	\$ 900.00
5730-64-642-42290	214148	JOHNSON MADISON LUMBER INC	9	I11-002890	\$ 19.70
5730-64-662-43590	214149	JOLLY JUMPER	9384	I11-002848	\$ 69.00
5730-64-662-42290	214150	K-MART	10	I11-002935	\$ 50.50
5730-64-662-42230	214165	MASCO JANITORIAL SUPPLY	198	I11-002699	\$ 308.36
5730-64-642-42290	214166	MASTERCARD PROCESSING CENTER	8270	I11-002806	\$ 24.97
5730-64-661-43420	214190	NORTHWESTERN ENERGY	82	I11-002931	\$ 2.49

City of Great Falls

Check Details Report (Date: 04/27/2011)

Account#	Check#	VendorName	Vendor#	Invoice#	Amount
5730-64-662-42190	214215	SAMS CLUB	4909	I11-002846	\$ 5.98
5730-64-662-42230	214215	SAMS CLUB	4909	I11-002846	\$ 101.64
5730-64-662-42290	214215	SAMS CLUB	4909	I11-002846	\$ 45.13

6055-14-181-45320	213942	DAVIS BUSINESS MACHINES	293	I11-002352	\$ 41.95
					Fund(5730) Total\$3,699.98
6055-14-181-43790	214059	WILLIAMS LINDA	2926	I11-002683	\$ 43.35
6055-14-181-42110	214198	PICKWICK'S OFFICE WORKS INC	367	I11-002918	\$ 37.99
6055-14-181-42190	214198	PICKWICK'S OFFICE WORKS INC	367	I11-002918	\$ 10.56

7910-00-000-20902	0	1ST INTERSTATE BANK	5320	I11-002796	\$ 82,496.45
					Fund(6055) Total\$133.85
7910-00-000-20905	0	1ST INTERSTATE BANK	5320	I11-002797	\$ 80,723.77
7910-00-000-20943	0	BENEVOLENT FUND	4301	I11-002794	\$ 930.00
7910-00-000-20947	0	CITY OF GREAT FALLS HEALTH	5319	I11-002795	\$ 194,704.00
7910-00-000-10100	0	CITY OF GREAT FALLS HEALTH	5319	I11-002795	\$ -194,704.00
7910-00-000-20908	0	FIREFIGHTER RETIREMENT SYS	4271	I11-002789	\$ 43,767.05
7910-00-000-20944	0	ICMA RETIREMENT TRUST-457	4245	I11-002773	\$ 12,003.73
7910-00-000-20945	0	NATIONWIDE RETIREMENT SOLUTIONS	13276	I11-002805	\$ 3,184.73
7910-00-000-20907	0	PUBLIC EMPLOYEE RETIREMENT SYS	4273	I11-002791	\$ 91,909.03
7910-00-000-20906	0	STATEWIDE POLICE RESERVE FUND	4272	I11-002790	\$ 54,351.85
7910-00-000-20953	213886	AFLAC	6735	I11-002798	\$ 4,892.42
7910-00-000-20955	213886	AFLAC	6735	I11-002799	\$ 5,806.24
7910-00-000-20958	213886	AFLAC	6735	I11-002800	\$ 375.34
7910-00-000-20959	213886	AFLAC	6735	I11-002801	\$ 1,144.17
7910-00-000-20941	213887	IAFF LOCAL #8 INT'L ASSOC FIRE FIG	4299	I11-002792	\$ 1,830.00
7910-00-000-20938	213888	INT'L BROTHERHOOD TEAMSTERS LOCAL 2	4259	I11-002784	\$ 1,421.00
7910-00-000-20933	213889	LIUNA LOCAL 1686	4242	I11-002771	\$ 3,283.50
7910-00-000-20939	213890	MONTANA PUBLIC EMPLOYEES ASSOC	4261	I11-002785	\$ 1,564.00
7910-00-000-20908	213891	MONTANA STATE FIREMAN'S ASSOC	4252	I11-001858	\$ 1,486.09
7910-00-000-20908	213891	MONTANA STATE FIREMAN'S ASSOC	4252	I11-002779	\$ 1,492.06

City of Great Falls

Check Details Report (Date: 04/27/2011)

Account#	Check#	VendorName	Vendor#	Invoice#	Amount
7910-00-000-20904	213892	MT STATE TREASURER PAYROLL	4244	I11-002772	\$ 36,163.00
7910-00-000-20936	213893	OPERATING ENGINEERS LOCAL 400	4250	I11-001856	\$ 1,141.62
7910-00-000-20936	213893	OPERATING ENGINEERS LOCAL 400	4250	I11-002777	\$ 1,278.33
7910-00-000-20940	213894	PACIFIC NORTHWEST REGIONAL	4263	I11-002786	\$ 45.80
7910-00-000-20942	213895	POLICE SAVINGS & LOAN	4300	I11-002793	\$ 11,839.00
7910-00-000-20922	213896	SYMETRA LIFE INSURANCE COMPANY	9270	I11-002802	\$ 348.70
7910-00-000-20922	213897	UNITED FUND	4264	I11-002787	\$ 469.44

6052-00-000-10100	0	CITY OF GREAT FALLS HEALTH	5319	Fund(7910) Total I11-002795	\$443,947.32 \$ 194,704.00
6052-15-267-34198	0	CITY OF GREAT FALLS HEALTH	5319	I11-002795	\$ -194,704.00
6052-15-267-45130	214115	ENCOURAGEMENT COUNSELING CENTER	13388	I11-003032	\$ 40.00

2430-31-536-43690	214048	UNITED ELECTRIC LLC	12906	Fund(6052) Total I11-002360	\$40.00 \$ 531.41

6050-15-266-45110	213921	BROADCAST MUSIC INC	8928	Fund(2430) Total I11-002407	\$531.41 \$ 553.50
6050-15-266-45110	213960	HAAS & WILKERSON HOLDINGS INC	2909	I11-002398	\$ 103.00
6050-15-266-42190	214013	PICKWICK'S OFFICE WORKS INC	367	I11-002427	\$ 52.66
6050-15-266-45125	214024	Russell Klette	12645	I11-002584	\$ 2,995.00
6050-15-266-42190	214198	PICKWICK'S OFFICE WORKS INC	367	I11-002942	\$ 11.95

2510-64-635-42290	213915	BIG R STORES (CSWW INC)	40	Fund(6050) Total I11-002593	\$3,716.11 \$ 5.88
2510-64-635-43590	213927	CARNAHAN TOWING & REPAIR INC	3263	I11-002430	\$ 150.00
2510-64-635-43560	213930	CHEMNET CONSORTIUM INC (THE)	11998	I11-002469	\$ 99.00
2510-64-635-42290	213951	FLEET SUPPLY COMPANY	64	I11-002656	\$ 11.08
2510-64-635-42290	214020	RESPOND SYSTEMS	7214	I11-002594	\$ 95.96
2510-64-634-42290	214020	RESPOND SYSTEMS	7214	I11-002594	\$ 95.96
2510-64-635-43590	214046	TREE MAN (THE)	6862	I11-002423	\$ 1,296.00
2510-64-635-43590	214046	TREE MAN (THE)	6862	I11-002425	\$ 696.00
2510-64-634-42210	214123	FORDE NURSERY INC	916	I11-002837	\$ 55.84
2510-64-635-42290	214148	JOHNSON MADISON LUMBER INC	9	I11-002938	\$ 17.97

City of Great Falls

Check Details Report (Date: 04/27/2011)

Account#	Check#	VendorName	Vendor#	Invoice#	Amount
2510-64-634-42290	214148	JOHNSON MADISON LUMBER INC	9	I11-002938	\$ 17.98
2510-64-634-43420	214190	NORTHWESTERN ENERGY	82	I11-002931	\$ 8.63

5315-31-575-49310	213959	GREAT FALLS TRIBUNE	77	I11-002422	\$ 496.60
					Fund(2510) Total\$2,550.30
5315-31-575-43590	213962	HDR ENGINEERING INC	10970	I11-002478	\$ 2,594.96
5315-31-575-43355	213998	MT DEPT OF ENVIRONMENTAL QUALITY WA	6873	I11-002645	\$ 4,995.00
5315-31-575-49310	214181	MT DEPT OF REVENUE 1% WITHHOLDING	136	I11-002941	\$ 263.88
5315-31-575-49310	214197	PHILLIPS CONSTRUCTION	9122	I11-002940	\$ 26,124.12

6030-15-212-43630	213967	IBM CORPORATION	3695	I11-002488	\$ 495.00
					Fund(5315) Total\$34,474.56
6030-15-212-43690	213984	MASTERCARD PROCESSING CENTER	8270	I11-002489	\$ 232.00
6030-15-213-42190	214013	PICKWICK'S OFFICE WORKS INC	367	I11-002491	\$ 8.79
6030-15-212-43412	214018	QWEST	81	I11-002493	\$ 1,154.25
6030-15-212-43412	214018	QWEST	81	I11-002494	\$ 1,589.16
6030-15-212-43412	214019	QWEST COMMUNICATIONS COMPANY LLC	9903	I11-002496	\$ 8,551.73
6030-15-212-43630	214139	INFOPRINT SOLUTIONS COMPANY LLC	12716	I11-002919	\$ 924.00
6030-15-212-43630	214139	INFOPRINT SOLUTIONS COMPANY LLC	12716	I11-002920	\$ 447.72
6030-15-212-42130	214198	PICKWICK'S OFFICE WORKS INC	367	I11-002922	\$ 219.44
6030-15-214-42120	214241	VERMONT SYSTEMS INC	12294	I11-002921	\$ 750.00

1000-15-281-48130	0	MUNICIPAL COURT	13557	I11-002830	\$ 10.00
					Fund(6030) Total\$14,372.09
1000-64-633-42330	213899	ACE HARDWARE	4876	I11-002470	\$ 17.99
1000-21-314-42230	213899	ACE HARDWARE	4876	I11-002650	\$ 36.89
1000-21-314-42390	213899	ACE HARDWARE	4876	I11-002650	\$ 13.99
1000-21-314-42390	213899	ACE HARDWARE	4876	I11-002651	\$ -1.00
1000-00-000-21421	213903	Arthur Girdwood	12707	I11-002622	\$ 15.00
1000-00-000-21422	213903	Arthur Girdwood	12707	I11-002622	\$ 200.00
1000-14-192-42120	213907	AV CAPTURE ALL INC	13517	I11-002351	\$ 199.00
1000-21-341-34418	213912	BEST FRIENDS ANIMAL HOSPITAL PC	9117	I11-002610	\$ 69.53

City of Great Falls

Check Details Report (Date: 04/27/2011)

Account#	Check#	VendorName	Vendor#	Invoice#	Amount
1000-15-282-43520	213913	BEST INTERPRETING SERVICES	11698	I11-002374	\$ 50.00
1000-64-633-42290	213915	BIG R STORES (CSWW INC)	40	I11-002449	\$ 12.98
1000-64-633-42290	213915	BIG R STORES (CSWW INC)	40	I11-002458	\$ 27.47
1000-64-633-42330	213915	BIG R STORES (CSWW INC)	40	I11-002471	\$ 11.77
1000-64-633-42330	213915	BIG R STORES (CSWW INC)	40	I11-002479	\$ 77.53
1000-00-000-21421	213916	BIG SKY ANIMAL MEDICAL CENTER	12915	I11-002615	\$ 135.00
1000-14-111-42290	213920	BOYD COFFEE COMPANY	3264	I11-002704	\$ 143.26
1000-21-321-42250	213923	BURROW, TRAVIS	13554	I11-002684	\$ 62.97
1000-21-341-43590	213926	CAREER QUEST	13466	I11-002649	\$ 922.50
1000-21-311-43210	213928	CASCADE COUNTY PRINT SHOP	8479	I11-002346	\$ 40.00
1000-24-411-43210	213928	CASCADE COUNTY PRINT SHOP	8479	I11-002346	\$ 61.00
1000-00-000-21422	213929	Charles Lehman	12707	I11-002617	\$ 200.00
1000-21-324-43790	213933	CODE 4 PUBLIC SAFETY EDUCATION ASSO	12450	I11-002254	\$ 495.00
1000-21-311-45190	213934	COGSWELL AGENCY	164	I11-002652	\$ 50.00
1000-64-633-42290	213936	COMMERCIAL MAINTENANCE CHEMICAL CORP	13526	I11-002484	\$ 99.99
1000-64-633-42290	213936	COMMERCIAL MAINTENANCE CHEMICAL CORP	13526	I11-002484	\$ 31.36
1000-11-091-45320	213942	DAVIS BUSINESS MACHINES	293	I11-002352	\$ 41.96
1000-14-111-45320	213942	DAVIS BUSINESS MACHINES	293	I11-002352	\$ 41.95
1000-14-114-45320	213942	DAVIS BUSINESS MACHINES	293	I11-002352	\$ 41.95
1000-15-281-43630	213942	DAVIS BUSINESS MACHINES	293	I11-002377	\$ 98.00
1000-21-341-42190	213942	DAVIS BUSINESS MACHINES	293	I11-002646	\$ 68.42
1000-00-000-21422	213948	Edessa Staiger	12707	I11-002625	\$ 200.00
1000-64-633-42350	213949	FASTENAL COMPANY	7664	I11-002444	\$ 11.65
1000-64-633-42290	213951	FLEET SUPPLY COMPANY	64	I11-002446	\$ 1.26
1000-64-633-42290	213951	FLEET SUPPLY COMPANY	64	I11-002447	\$ 416.00
1000-64-633-42290	213951	FLEET SUPPLY COMPANY	64	I11-002457	\$ 12.98
1000-14-171-43520	213953	GARLINGTON, LOHN & ROBINSON PLLP	13531	I11-002426	\$ 2,152.80
1000-00-000-21422	213973	John Rummel	12707	I11-002623	\$ 200.00
1000-64-633-42290	213974	JOHNSON MADISON LUMBER INC	9	I11-002343	\$ 142.96

City of Great Falls

Check Details Report (Date: 04/27/2011)

Account#	Check#	VendorName	Vendor#	Invoice#	Amount
1000-64-633-42290	213974	JOHNSON MADISON LUMBER INC	9	I11-002345	\$ 34.45
1000-64-633-42290	213974	JOHNSON MADISON LUMBER INC	9	I11-002347	\$ 25.21
1000-64-633-42350	213974	JOHNSON MADISON LUMBER INC	9	I11-002348	\$ 53.16
1000-64-633-42290	213974	JOHNSON MADISON LUMBER INC	9	I11-002349	\$ 30.90
1000-64-633-42290	213974	JOHNSON MADISON LUMBER INC	9	I11-002350	\$ 15.80
1000-64-633-42290	213974	JOHNSON MADISON LUMBER INC	9	I11-002443	\$ 12.50
1000-64-633-42290	213974	JOHNSON MADISON LUMBER INC	9	I11-002472	\$ 13.70
1000-00-000-21421	213975	Joseph McCarthy	12707	I11-002616	\$ 15.00
1000-00-000-21400	213976	K-Mart	3702	I11-002424	\$ 426.00
1000-00-000-21422	213977	Kimberly Flood	12707	I11-002624	\$ 200.00
1000-21-311-42290	213983	MASCO JANITORIAL SUPPLY	198	I11-002648	\$ 38.99
1000-21-314-42230	213983	MASCO JANITORIAL SUPPLY	198	I11-002648	\$ 37.95
1000-21-315-42290	213984	MASTERCARD PROCESSING CENTER	8270	I11-002689	\$ 72.95
1000-21-391-43590	213984	MASTERCARD PROCESSING CENTER	8270	I11-002690	\$ 88.14
1000-21-325-43790	213984	MASTERCARD PROCESSING CENTER	8270	I11-002690	\$ 42.92
1000-21-325-43790	213984	MASTERCARD PROCESSING CENTER	8270	I11-002690	\$ 43.48
1000-14-195-43590	213984	MASTERCARD PROCESSING CENTER	8270	I11-002693	\$ 496.00
1000-21-312-43590	213985	MDHHS MT DEAF & HARD OF HEARING SER	8916	I11-002632	\$ 60.00
1000-00-000-21422	213989	Mona Reiner	12707	I11-002620	\$ 200.00
1000-21-311-45190	213992	MONTANA SECRETARY OF STATE	5793	I11-002653	\$ 25.00
1000-64-633-43445	213993	MONTANA WASTE SYSTEMS INC	8467	I11-002323	\$ 168.73
1000-21-341-42310	213995	MOUNTAIN VIEW CO-OP	972	I11-002628	\$ 38.59
1000-21-341-42310	213995	MOUNTAIN VIEW CO-OP	972	I11-002629	\$ 167.77
1000-21-341-42310	213995	MOUNTAIN VIEW CO-OP	972	I11-002630	\$ 226.01
1000-21-341-42310	213995	MOUNTAIN VIEW CO-OP	972	I11-002631	\$ 135.06
1000-14-114-43790	213996	MSU LOCAL GOVERNMENT CENTER	6406	I11-002442	\$ 235.00
1000-64-633-42330	214000	NAPA AUTO PARTS OF GREAT FALLS	68	I11-002474	\$ 1.76
1000-64-633-42240	214001	NATIONAL LAUNDRY	388	I11-002453	\$ 10.56
1000-64-633-42210	214006	NORTHWEST PIPE FITTINGS INC	142	I11-002459	\$ 31.60

City of Great Falls

Check Details Report (Date: 04/27/2011)

Account#	Check#	VendorName	Vendor#	Invoice#	Amount
1000-64-633-42210	214006	NORTHWEST PIPE FITTINGS INC	142	I11-002460	\$ 31.60
1000-64-633-42210	214006	NORTHWEST PIPE FITTINGS INC	142	I11-002462	\$ 53.98
1000-64-633-42210	214006	NORTHWEST PIPE FITTINGS INC	142	I11-002464	\$ 10.74
1000-64-633-42210	214006	NORTHWEST PIPE FITTINGS INC	142	I11-002465	\$ 125.42
1000-64-633-42210	214006	NORTHWEST PIPE FITTINGS INC	142	I11-002480	\$ 1,439.20
1000-64-633-43420	214007	NORTHWESTERN ENERGY	82	I11-002647	\$ 161.52
1000-21-315-43750	214011	PETTY CASH/ GROVE CLOYD	12335	I11-002692	\$ 11.38
1000-21-324-43790	214011	PETTY CASH/ GROVE CLOYD	12335	I11-002692	\$ 39.80
1000-21-315-43750	214011	PETTY CASH/ GROVE CLOYD	12335	I11-002692	\$ 19.76
1000-15-282-42190	214013	PICKWICK'S OFFICE WORKS INC	367	I11-002371	\$ 20.92
1000-15-282-42190	214013	PICKWICK'S OFFICE WORKS INC	367	I11-002409	\$ 257.57
1000-14-171-42190	214013	PICKWICK'S OFFICE WORKS INC	367	I11-002413	\$ 34.11
1000-14-171-42190	214013	PICKWICK'S OFFICE WORKS INC	367	I11-002416	\$ 36.48
1000-14-171-42190	214013	PICKWICK'S OFFICE WORKS INC	367	I11-002418	\$ 373.09
1000-14-171-42190	214013	PICKWICK'S OFFICE WORKS INC	367	I11-002419	\$ 148.86
1000-14-114-42190	214013	PICKWICK'S OFFICE WORKS INC	367	I11-002450	\$ 53.92
1000-14-114-42190	214013	PICKWICK'S OFFICE WORKS INC	367	I11-002452	\$ 55.84
1000-21-311-42190	214013	PICKWICK'S OFFICE WORKS INC	367	I11-002641	\$ 191.38
1000-21-315-42290	214013	PICKWICK'S OFFICE WORKS INC	367	I11-002643	\$ 27.74
1000-21-315-42220	214013	PICKWICK'S OFFICE WORKS INC	367	I11-002644	\$ 7.50
1000-64-633-42290	214014	PROBUILD	25	I11-002445	\$ 22.07
1000-64-633-42290	214014	PROBUILD	25	I11-002468	\$ 7.38
1000-15-282-43410	214018	QWEST	81	I11-002378	\$ 44.38
1000-21-341-43412	214018	QWEST	81	I11-002670	\$ 313.83
1000-00-000-21422	214028	Sean Edelen	12707	I11-002626	\$ 200.00
1000-21-341-42390	214032	SMITH EQUIPMENT CO	2317	I11-002627	\$ 200.50
1000-15-283-43520	214038	SUTTON & DUBOIS PLLC	13474	I11-002359	\$ 460.00
1000-14-171-43410	214052	VERIZON WIRELESS	10858	I11-002421	\$ 153.91
1000-15-282-43410	214053	VISION NET INC	11369	I11-002376	\$ 249.00
1000-00-000-21421	214054	Wanda Banks	12707	I11-002618	\$ 15.00

City of Great Falls

Check Details Report (Date: 04/27/2011)

Account#	Check#	VendorName	Vendor#	Invoice#	Amount
1000-00-000-21422	214054	Wanda Banks	12707	I11-002618	\$ 200.00
1000-21-341-43590	214056	WESTSIDE ANIMAL CLINIC	3378	I11-002598	\$ 15.00
1000-64-633-42290	214058	WILBUR-ELLIS COMPANY	1652	I11-002482	\$ 1,375.00
1000-00-000-12400	214060	BRAGG JEFF	10800	I11-002993	\$ 328.78
1000-00-000-12400	214061	SHANKS TIMOTHY	1144	I11-002991	\$ 389.00
1000-21-341-42290	214063	ACE HARDWARE	4876	I11-002989	\$ 266.68
1000-15-282-43525	214065	AMANDA LYNNE WILLIAMS	3702	I11-003064	\$ 24.00
1000-00-000-21421	214070	ANIMAL MEDICAL CLINIC	506	I11-003022	\$ 135.00
1000-15-282-43525	214071	ANTOINETTE GIONO WELLS	3702	I11-003086	\$ 12.00
1000-64-622-42520	214079	BELTER PAT	12408	I11-002751	\$ 36.00
1000-21-312-43560	214080	BENEFIS HEALTH SYSTEM (TESTING)	6751	I11-002964	\$ 300.00
1000-21-341-43590	214081	BEST FRIENDS ANIMAL HOSPITAL PC	9117	I11-002952	\$ 43.00
1000-00-000-21421	214082	BEST FRIENDS ANIMAL HOSPITAL PC	9117	I11-002955	\$ 75.00
1000-15-282-43520	214083	BEST INTERPRETING SERVICES	11698	I11-002813	\$ 100.00
1000-00-000-21461	214084	Bethel Lutheran Church	12646	I11-002763	\$ 75.00
1000-21-341-42290	214085	BIG R STORES (CSWW INC)	40	I11-002986	\$ 1,571.78
1000-15-282-43525	214089	BLYTHE D BRANDVOLD	3702	I11-003070	\$ 12.00
1000-21-341-43355	214090	Board of Veterinary Medicine	12707	I11-002996	\$ 70.00
1000-21-341-43355	214091	Board of Veterinary Medicine	12707	I11-002997	\$ 70.00
1000-21-341-43355	214092	Board of Veterinary Medicine	12707	I11-002994	\$ 125.00
1000-15-282-43525	214093	BRENDA SUE ROBERTSON JOHNSON	3702	I11-003061	\$ 24.00
1000-21-341-43590	214096	CAREER QUEST	13466	I11-002966	\$ 635.50
1000-21-341-43590	214096	CAREER QUEST	13466	I11-002966	\$ 623.20
1000-21-341-42230	214098	CHEMICAL MONTANA COMPANY	2321	I11-001628	\$ 136.75
1000-64-633-42350	214101	CONSOLIDATED ELECTRICAL DIST INC	52	I11-002819	\$ 14.45
1000-15-282-43525	214104	DANIEL SHERWOOD CARLSON	3702	I11-003084	\$ 12.00
1000-00-000-12400	214105	DANIELS SHANE	12705	I11-003170	\$ 1,037.00
1000-15-282-43525	214106	DANN WILLIAM YOUNG	3702	I11-003095	\$ 12.00
1000-21-311-45320	214107	DE LAGE LANDEN FINANCIAL SERVICES I	13323	I11-002959	\$ 589.00
1000-15-282-43525	214108	DIANA COUGHLIN ALBAUGH	3702	I11-003075	\$ 12.00

City of Great Falls

Check Details Report (Date: 04/27/2011)

Account#	Check#	VendorName	Vendor#	Invoice#	Amount
1000-15-282-43525	214110	DONALD D JUNG	3702	I11-003068	\$ 24.00
1000-21-311-45190	214111	DOUBLE G ENGRAVING & AWARDS	5178	I11-002958	\$ 50.00
1000-21-341-43590	214114	ECOLAB PEST ELIMINATION	4334	I11-002998	\$ 52.00
1000-21-314-43630	214114	ECOLAB PEST ELIMINATION	4334	I11-002999	\$ 96.00
1000-21-326-43350	214118	EQUIFAX INFORMATION SERVICES LLC	3949	I11-003001	\$ 20.11
1000-64-622-43690	214120	FERGUSON ENTERPRISES INC #3201	8915	I11-002899	\$ 40.83
1000-21-341-42290	214121	FLEET SUPPLY COMPANY	64	I11-002985	\$ 767.70
1000-64-633-42290	214126	GENERAL DISTRIBUTING CO	65	I11-002847	\$ 76.57
1000-15-282-43525	214127	GERI LYNN PANKOWSKI	3702	I11-003103	\$ 12.00
1000-21-314-42230	214129	GREAT FALLS PAPER & SUPPLY CO	549	I11-002963	\$ 192.43
1000-21-326-43560	214133	HESSEL-FALLS NEUROPSYCHOLOGICAL SRV	12104	I11-002962	\$ 100.00
1000-64-622-42520	214134	HUCKLEBERRY HAVEN INC	11742	I11-002752	\$ 747.76
1000-15-282-43525	214142	JACK MCFETRIDGE	3702	I11-003076	\$ 12.00
1000-15-282-43525	214144	JESSICA MARGARET FICK	3702	I11-003092	\$ 12.00
1000-15-282-43525	214145	JILL PAULINE MILLER	3702	I11-003096	\$ 12.00
1000-64-633-42350	214148	JOHNSON MADISON LUMBER INC	9	I11-002842	\$ 11.95
1000-64-633-42290	214148	JOHNSON MADISON LUMBER INC	9	I11-002843	\$ 15.95
1000-64-633-42290	214148	JOHNSON MADISON LUMBER INC	9	I11-002844	\$ 15.95
1000-15-282-43525	214152	KATRINA MARIE HEARNS	3702	I11-003098	\$ 12.00
1000-15-282-43525	214155	KRISTINA ANN PASAK	3702	I11-003072	\$ 12.00
1000-15-282-43525	214157	LARRY ALLEN DHOOGHE	3702	I11-003062	\$ 24.00
1000-64-633-42290	214158	LAWSON PRODUCTS INC	6589	I11-002849	\$ 78.54
1000-64-633-42290	214158	LAWSON PRODUCTS INC	6589	I11-002851	\$ 336.92
1000-15-282-43525	214159	LEE A HICKEY	3702	I11-003105	\$ 12.00
1000-15-282-43525	214161	LISA MARIE GASKELL	3702	I11-003082	\$ 12.00
1000-00-000-21422	214163	Marci Ridgeway	12707	I11-002957	\$ 100.00
1000-15-282-43525	214164	MARYLYN M FRIESEN	3702	I11-003100	\$ 12.00
1000-21-311-42290	214165	MASCO JANITORIAL SUPPLY	198	I11-002960	\$ 78.98
1000-21-314-42230	214165	MASCO JANITORIAL SUPPLY	198	I11-002960	\$ 229.31

City of Great Falls

Check Details Report (Date: 04/27/2011)

Account#	Check#	VendorName	Vendor#	Invoice#	Amount
1000-21-341-42290	214166	MASTERCARD PROCESSING CENTER	8270	I11-002691	\$ 100.34
1000-21-341-42190	214166	MASTERCARD PROCESSING CENTER	8270	I11-002691	\$ 19.51
1000-21-341-42190	214166	MASTERCARD PROCESSING CENTER	8270	I11-002691	\$ 159.98
1000-21-341-42290	214166	MASTERCARD PROCESSING CENTER	8270	I11-002691	\$ 63.56
1000-21-341-42290	214166	MASTERCARD PROCESSING CENTER	8270	I11-002691	\$ 63.30
1000-21-341-42230	214166	MASTERCARD PROCESSING CENTER	8270	I11-002691	\$ 35.14
1000-21-341-42290	214166	MASTERCARD PROCESSING CENTER	8270	I11-002691	\$ 231.44
1000-21-341-42290	214166	MASTERCARD PROCESSING CENTER	8270	I11-002691	\$ 35.73
1000-21-341-42290	214166	MASTERCARD PROCESSING CENTER	8270	I11-002691	\$ 54.97
1000-21-341-42290	214166	MASTERCARD PROCESSING CENTER	8270	I11-002691	\$ 423.85
1000-21-341-42310	214166	MASTERCARD PROCESSING CENTER	8270	I11-002691	\$ 14.34
1000-21-341-42230	214166	MASTERCARD PROCESSING CENTER	8270	I11-002691	\$ 41.66
1000-21-341-42190	214166	MASTERCARD PROCESSING CENTER	8270	I11-002691	\$ 61.42
1000-14-112-43790	214166	MASTERCARD PROCESSING CENTER	8270	I11-002923	\$ 225.00
1000-15-282-43525	214169	MOLLIE MAY BROWN	3702	I11-003074	\$ 12.00
1000-64-622-42520	214171	Montana Grassland Mixes	12646	I11-002750	\$ 102.00
1000-21-311-43810	214172	MONTANA LAW ENFORCEMENT ACADEMY	1972	I11-003140	\$ 20.00
1000-64-622-42520	214174	Mountain Press Publishing Company	12646	I11-002748	\$ 243.00
1000-21-341-42310	214175	MOUNTAIN VIEW CO-OP	972	I11-002978	\$ 96.48
1000-21-341-42310	214175	MOUNTAIN VIEW CO-OP	972	I11-002979	\$ 96.47
1000-21-341-42310	214175	MOUNTAIN VIEW CO-OP	972	I11-002980	\$ 96.47
1000-21-341-42310	214175	MOUNTAIN VIEW CO-OP	972	I11-002981	\$ 179.45
1000-21-341-42310	214175	MOUNTAIN VIEW CO-OP	972	I11-002982	\$ 443.78
1000-21-341-42310	214175	MOUNTAIN VIEW CO-OP	972	I11-002983	\$ 192.95
1000-21-341-42310	214175	MOUNTAIN VIEW CO-OP	972	I11-002984	\$ 192.95
1000-21-324-43790	214176	MSTOA MOUNTAIN STATE TACTICAL	10703	I11-003160	\$ 450.00
1000-11-091-43390	214177	MSU LOCAL GOVERNMENT CENTER	6406	I11-002933	\$ 150.00
1000-24-461-43790	214178	MSU-B CPSLL	12644	I11-002967	\$ 75.00
1000-15-281-43526	214182	MUNICIPAL SERVICES BUREAU	9283	I11-002814	\$ 312.80

City of Great Falls

Check Details Report (Date: 04/27/2011)

Account#	Check#	VendorName	Vendor#	Invoice#	Amount
1000-64-633-42240	214184	NATIONAL LAUNDRY	388	I11-002816	\$ 7.08
1000-64-633-42210	214189	NORTHWEST PIPE FITTINGS INC	142	I11-002807	\$ 58.10
1000-64-633-42210	214189	NORTHWEST PIPE FITTINGS INC	142	I11-002809	\$ 33.60
1000-64-633-42210	214189	NORTHWEST PIPE FITTINGS INC	142	I11-002811	\$ 69.00
1000-64-633-42210	214189	NORTHWEST PIPE FITTINGS INC	142	I11-002815	\$ 900.00
1000-64-633-42210	214189	NORTHWEST PIPE FITTINGS INC	142	I11-002815	\$ 9.30
1000-64-621-43420	214190	NORTHWESTERN ENERGY	82	I11-002931	\$ 1.76
1000-64-633-43420	214190	NORTHWESTERN ENERGY	82	I11-002931	\$ 372.09
1000-00-000-21422	214194	Patricia Bauer	12707	I11-003143	\$ 200.00
1000-64-633-42290	214198	PICKWICK'S OFFICE WORKS INC	367	I11-002817	\$ 20.99
1000-15-281-42190	214198	PICKWICK'S OFFICE WORKS INC	367	I11-002868	\$ 4.49
1000-15-281-42190	214198	PICKWICK'S OFFICE WORKS INC	367	I11-002869	\$ 6.15
1000-15-282-42190	214198	PICKWICK'S OFFICE WORKS INC	367	I11-002871	\$ -6.15
1000-11-091-42190	214198	PICKWICK'S OFFICE WORKS INC	367	I11-002918	\$ 37.99
1000-14-114-42190	214198	PICKWICK'S OFFICE WORKS INC	367	I11-002918	\$ 47.15
1000-14-111-42190	214198	PICKWICK'S OFFICE WORKS INC	367	I11-002918	\$ 48.55
1000-21-311-42190	214198	PICKWICK'S OFFICE WORKS INC	367	I11-002969	\$ 412.95
1000-21-314-42290	214198	PICKWICK'S OFFICE WORKS INC	367	I11-002969	\$ 95.42
1000-21-312-42290	214198	PICKWICK'S OFFICE WORKS INC	367	I11-002969	\$ 54.63
1000-21-315-42220	214198	PICKWICK'S OFFICE WORKS INC	367	I11-002969	\$ 54.63
1000-21-311-42190	214198	PICKWICK'S OFFICE WORKS INC	367	I11-003014	\$ 248.99
1000-21-315-42220	214198	PICKWICK'S OFFICE WORKS INC	367	I11-003014	\$ 671.97
1000-21-315-42290	214198	PICKWICK'S OFFICE WORKS INC	367	I11-003014	\$ 1,429.92
1000-21-311-42190	214198	PICKWICK'S OFFICE WORKS INC	367	I11-003017	\$ -248.99
1000-21-315-42220	214198	PICKWICK'S OFFICE WORKS INC	367	I11-003017	\$ -447.98
1000-21-311-42190	214198	PICKWICK'S OFFICE WORKS INC	367	I11-003137	\$ 75.78
1000-15-281-42120	214200	PRECISE DIGITAL LLC	13286	I11-002859	\$ 299.00
1000-64-633-43412	214203	QWEST	81	I11-002934	\$ 35.54
1000-21-341-34410	214206	Rick Brinka	12707	I11-003020	\$ 65.00
1000-00-000-21421	214206	Rick Brinka	12707	I11-003020	\$ 15.00

City of Great Falls

Check Details Report (Date: 04/27/2011)

Account#	Check#	VendorName	Vendor#	Invoice#	Amount
1000-15-282-43525	214207	RICKY RAY LOPEZ	3702	I11-003078	\$ 12.00
1000-15-282-43525	214209	ROBERT PAULEY	3702	I11-003104	\$ 12.00
1000-15-282-43525	214212	ROGER DALE MAY	3702	I11-003060	\$ 24.00
1000-64-622-42520	214214	S-K Designs	12646	I11-002747	\$ 308.38
1000-15-282-43525	214218	SHELLEY MARIE JENSEN	3702	I11-003063	\$ 24.00
1000-21-341-42290	214220	SHOPKO PROPERTIES LLC	30	I11-002987	\$ 19.99
1000-21-341-42290	214220	SHOPKO PROPERTIES LLC	30	I11-002988	\$ 175.75
1000-64-633-42330	214223	SMITH EQUIPMENT CO	2317	I11-002839	\$ 13.50
1000-14-111-43790	214226	THARES JOYCE	8355	I11-003108	\$ 65.10
1000-14-111-43790	214226	THARES JOYCE	8355	I11-003108	\$ 26.78
1000-15-282-43525	214234	TRACY L HILL	3702	I11-003080	\$ 12.00
1000-64-633-43415	214240	VERIZON WIRELESS	10858	I11-002939	\$ 125.19
1000-64-633-43415	214240	VERIZON WIRELESS	10858	I11-003003	\$ 125.19
1000-64-633-43415	214240	VERIZON WIRELESS	10858	I11-003004	\$ 125.19
1000-64-621-42190	214242	WARDEN PAPER CO	1922	I11-002857	\$ 525.00
1000-64-633-43415	214244	WCS TELECOM	11222	I11-003005	\$ 51.52

					Fund(1000) Total\$36,023.55
6010-31-513-42290	213899	ACE HARDWARE	4876	I11-002399	\$ 45.97
6010-31-513-42320	213902	AMERICAN WELDING & GAS INC (VALLEY)	72	I11-002597	\$ 8.60
6010-31-513-42320	213905	AUTO ADDITIONS INC	13380	I11-002531	\$ 245.70
6010-31-513-42320	213905	AUTO ADDITIONS INC	13380	I11-002532	\$ 140.14
6010-31-513-43640	213906	AUTO TRIM DESIGN	599	I11-002397	\$ 25.00
6010-31-513-42320	213911	BEARING SALES INC	37	I11-002379	\$ 39.26
6010-31-513-42320	213911	BEARING SALES INC	37	I11-002384	\$ 19.63
6010-00-000-15110	213914	BEST OIL DISTRIBUTING	8163	I11-002606	\$ 1,980.00
6010-31-513-42290	213915	BIG R STORES (CSWW INC)	40	I11-002382	\$ 23.93
6010-31-513-43640	213918	BIG SKY HYDRAULICS & MACHINING INC	11168	I11-002387	\$ 172.94
6010-31-513-43640	213918	BIG SKY HYDRAULICS & MACHINING INC	11168	I11-002388	\$ 259.26
6010-31-513-43640	213918	BIG SKY HYDRAULICS & MACHINING INC	11168	I11-002389	\$ 65.00

City of Great Falls

Check Details Report (Date: 04/27/2011)

Account#	Check#	VendorName	Vendor#	Invoice#	Amount
6010-31-513-42320	213918	BIG SKY HYDRAULICS & MACHINING INC	11168	I11-002390	\$ 6.42
6010-31-513-42320	213918	BIG SKY HYDRAULICS & MACHINING INC	11168	I11-002392	\$ 45.57
6010-31-513-42320	213918	BIG SKY HYDRAULICS & MACHINING INC	11168	I11-002533	\$ 51.36
6010-31-513-42320	213918	BIG SKY HYDRAULICS & MACHINING INC	11168	I11-002534	\$ 99.80
6010-31-513-42320	213918	BIG SKY HYDRAULICS & MACHINING INC	11168	I11-002535	\$ 29.50
6010-31-513-42320	213918	BIG SKY HYDRAULICS & MACHINING INC	11168	I11-002536	\$ 102.16
6010-31-513-42320	213918	BIG SKY HYDRAULICS & MACHINING INC	11168	I11-002537	\$ 4,220.06
6010-31-513-42320	213918	BIG SKY HYDRAULICS & MACHINING INC	11168	I11-002599	\$ 176.79
6010-31-513-42320	213918	BIG SKY HYDRAULICS & MACHINING INC	11168	I11-002600	\$ 5.58
6010-31-513-42320	213918	BIG SKY HYDRAULICS & MACHINING INC	11168	I11-002601	\$ 1.76
6010-31-513-42320	213919	BISON MOTOR CO INC	42	I11-002538	\$ 142.76
6010-31-513-43620	213924	CALVERTS OVERHEAD DOOR SERVICE	11134	I11-002724	\$ 114.00
6010-31-513-42320	213925	CAPITAL COMMUNICATIONS	13091	I11-002522	\$ 545.00
6010-31-513-42320	213932	CITY MOTOR CO INC	267	I11-002372	\$ 996.27
6010-31-513-42320	213932	CITY MOTOR CO INC	267	I11-002373	\$ -433.72
6010-31-513-43640	213932	CITY MOTOR CO INC	267	I11-002404	\$ 134.40
6010-31-513-42320	213932	CITY MOTOR CO INC	267	I11-002727	\$ 22.63
6010-31-513-42320	213932	CITY MOTOR CO INC	267	I11-002729	\$ 24.38
6010-31-513-43620	213940	CRESCENT ELECTRIC SUPPLY CO	405	I11-002393	\$ 55.20
6010-31-513-42320	213944	DIRECT AUTOMOTIVE DISTRIBUTING	13156	I11-002394	\$ -76.38
6010-31-513-42320	213944	DIRECT AUTOMOTIVE DISTRIBUTING	13156	I11-002395	\$ 99.42
6010-31-513-42320	213944	DIRECT AUTOMOTIVE DISTRIBUTING	13156	I11-002396	\$ 86.24
6010-31-513-42320	213944	DIRECT AUTOMOTIVE DISTRIBUTING	13156	I11-002541	\$ 78.12
6010-31-513-42320	213944	DIRECT AUTOMOTIVE DISTRIBUTING	13156	I11-002543	\$ 38.49
6010-31-513-42320	213944	DIRECT AUTOMOTIVE DISTRIBUTING	13156	I11-002732	\$ 168.47
6010-31-513-42320	213950	FERGUSON ENTERPRISES INC #3201	8915	I11-002381	\$ 474.50
6010-31-513-42320	213951	FLEET SUPPLY COMPANY	64	I11-002402	\$ 45.58
6010-31-513-42290	213951	FLEET SUPPLY COMPANY	64	I11-002544	\$ 10.00
6010-31-513-42320	213951	FLEET SUPPLY COMPANY	64	I11-002545	\$ 5.97
6010-31-513-42320	213954	GENERAL DISTRIBUTING CO	65	I11-002733	\$ 52.73

City of Great Falls

Check Details Report (Date: 04/27/2011)

Account#	Check#	VendorName	Vendor#	Invoice#	Amount
6010-31-513-42320	213954	GENERAL DISTRIBUTING CO	65	I11-002734	\$ 52.73
6010-31-513-42320	213954	GENERAL DISTRIBUTING CO	65	I11-002735	\$ 84.63
6010-31-513-42320	213955	GERBERS OF MONTANA INC	66	I11-002386	\$ 1,565.90
6010-31-513-42320	213956	GRAFIX SHOPPE	7217	I11-002362	\$ 122.94
6010-31-513-42320	213964	HOVEN EQUIPMENT COMPANY	2095	I11-002546	\$ 24.54
6010-31-513-42320	213965	HUGHES FIRE EQUIPMENT INC	6714	I11-002602	\$ 253.53
6010-31-513-42320	213966	I STATE TRUCK CENTER INC	11353	I11-002408	\$ 18.13
6010-31-513-42320	213966	I STATE TRUCK CENTER INC	11353	I11-002410	\$ 54.33
6010-31-513-42320	213966	I STATE TRUCK CENTER INC	11353	I11-002411	\$ 34.29
6010-31-513-42320	213966	I STATE TRUCK CENTER INC	11353	I11-002412	\$ -34.29
6010-31-513-42320	213966	I STATE TRUCK CENTER INC	11353	I11-002414	\$ 74.28
6010-31-513-42320	213966	I STATE TRUCK CENTER INC	11353	I11-002548	\$ 1,743.06
6010-31-513-42320	213966	I STATE TRUCK CENTER INC	11353	I11-002603	\$ 59.22
6010-31-513-42320	213966	I STATE TRUCK CENTER INC	11353	I11-002604	\$ 65.00
6010-31-513-42320	213966	I STATE TRUCK CENTER INC	11353	I11-002607	\$ 25.00
6010-31-513-43640	213971	JERRYS RADIATOR SERVICE INC	7	I11-002375	\$ 68.00
6010-31-513-42320	213978	KOIS BROTHERS EQUIPMENT CO	643	I11-002550	\$ 3,458.12
6010-31-513-42320	213984	MASTERCARD PROCESSING CENTER	8270	I11-002467	\$ 61.34
6010-31-513-42190	213984	MASTERCARD PROCESSING CENTER	8270	I11-002588	\$ 11.00
6010-31-513-42320	213988	MIDLAND IMPLEMENT COMPANY INC	106	I11-002552	\$ 566.35
6010-31-513-42320	213991	MONTANA RADIATOR WORKS	13223	I11-002609	\$ 150.00
6010-31-513-42320	213994	MOODIE IMPLEMENT (FARM PLAN)	8656	I11-002383	\$ 140.00
6010-31-513-42320	214000	NAPA AUTO PARTS OF GREAT FALLS	68	I11-002366	\$ 29.40
6010-31-513-42320	214000	NAPA AUTO PARTS OF GREAT FALLS	68	I11-002367	\$ 7.76
6010-31-513-42320	214000	NAPA AUTO PARTS OF GREAT FALLS	68	I11-002368	\$ 8.94
6010-31-513-42320	214000	NAPA AUTO PARTS OF GREAT FALLS	68	I11-002369	\$ 4.77
6010-31-513-42320	214000	NAPA AUTO PARTS OF GREAT FALLS	68	I11-002370	\$ -29.40
6010-31-513-42320	214000	NAPA AUTO PARTS OF GREAT FALLS	68	I11-002525	\$ 86.81
6010-31-513-42320	214000	NAPA AUTO PARTS OF GREAT FALLS	68	I11-002526	\$ 9.76
6010-31-513-42320	214000	NAPA AUTO PARTS OF GREAT FALLS	68	I11-002527	\$ 10.88

City of Great Falls

Check Details Report (Date: 04/27/2011)

Account#	Check#	VendorName	Vendor#	Invoice#	Amount
6010-31-513-42320	214000	NAPA AUTO PARTS OF GREAT FALLS	68	I11-002528	\$ -10.88
6010-31-513-42320	214000	NAPA AUTO PARTS OF GREAT FALLS	68	I11-002529	\$ 8.28
6010-31-513-42320	214000	NAPA AUTO PARTS OF GREAT FALLS	68	I11-002596	\$ 20.23
6010-31-513-45390	214001	NATIONAL LAUNDRY	388	I11-002516	\$ 84.77
6010-31-513-45390	214001	NATIONAL LAUNDRY	388	I11-002586	\$ 67.63
6010-31-513-42320	214004	NORMONT EQUIPMENT CO	15	I11-002554	\$ 50.92
6010-00-000-15110	214004	NORMONT EQUIPMENT CO	15	I11-002605	\$ 3,297.00
6010-31-513-42320	214005	NORTHERN HYDRAULICS INC	2387	I11-002556	\$ 63.06
6010-31-513-42320	214006	NORTHWEST PIPE FITTINGS INC	142	I11-002737	\$ 591.10
6010-31-513-42320	214009	OREILLY AUTO PARTS	12052	I11-002363	\$ 56.74
6010-31-513-42320	214009	OREILLY AUTO PARTS	12052	I11-002364	\$ 171.49
6010-31-513-42320	214009	OREILLY AUTO PARTS	12052	I11-002365	\$ 4.99
6010-31-513-42320	214009	OREILLY AUTO PARTS	12052	I11-002518	\$ 171.49
6010-31-513-42320	214009	OREILLY AUTO PARTS	12052	I11-002519	\$ 15.89
6010-31-513-42190	214013	PICKWICK'S OFFICE WORKS INC	367	I11-002361	\$ 45.65
6010-31-513-42190	214013	PICKWICK'S OFFICE WORKS INC	367	I11-002466	\$ 52.49
6010-31-513-43410	214018	QWEST	81	I11-002487	\$ 43.16
6010-31-513-42320	214023	ROCKY MOUNTAIN TRUCK SERVICE INC	9846	I11-002380	\$ 3,109.66
6010-31-513-42320	214023	ROCKY MOUNTAIN TRUCK SERVICE INC	9846	I11-002557	\$ 199.99
6010-31-513-42320	214023	ROCKY MOUNTAIN TRUCK SERVICE INC	9846	I11-002558	\$ 381.88
6010-31-513-42320	214023	ROCKY MOUNTAIN TRUCK SERVICE INC	9846	I11-002739	\$ 137.41
6010-31-513-43640	214037	SUPERIOR TIRE INC	10829	I11-002405	\$ 67.90
6010-31-513-43640	214037	SUPERIOR TIRE INC	10829	I11-002406	\$ 50.50
6010-31-513-42320	214037	SUPERIOR TIRE INC	10829	I11-002741	\$ 850.60
6010-31-513-42320	214039	TAYLOR BROTHERS INC	180	I11-002385	\$ 315.52
6010-31-513-42320	214040	TC GLASS DISTRIBUTOR INC	34	I11-002561	\$ 56.05
6010-31-513-42320	214040	TC GLASS DISTRIBUTOR INC	34	I11-002611	\$ 49.74
6010-31-513-42320	214041	TIRE FACTORY	9864	I11-002530	\$ 60.00
6010-31-513-42320	214042	TIRE-RAMA	678	I11-002562	\$ 419.90
6010-31-513-42320	214043	TITAN MACHINERY INC	75	I11-002403	\$ 239.54

City of Great Falls

Check Details Report (Date: 04/27/2011)

Account#	Check#	VendorName	Vendor#	Invoice#	Amount
6010-31-513-42320	214043	TITAN MACHINERY INC	75	I11-002567	\$ 62.92
6010-31-513-42320	214043	TITAN MACHINERY INC	75	I11-002569	\$ 23.30
6010-31-513-43640	214043	TITAN MACHINERY INC	75	I11-002613	\$ 999.71
6010-31-513-42320	214043	TITAN MACHINERY INC	75	I11-002614	\$ 606.47
6010-31-513-42320	214044	TNT SPRINGS INC / TNT TRUCK PARTS	12089	I11-002570	\$ 7.75
6010-31-513-42320	214044	TNT SPRINGS INC / TNT TRUCK PARTS	12089	I11-002572	\$ 508.98
6010-31-513-42320	214044	TNT SPRINGS INC / TNT TRUCK PARTS	12089	I11-002575	\$ 93.10
6010-31-513-42320	214045	TRACTOR & EQUIPMENT CO	69	I11-002400	\$ 16.04
6010-31-513-42320	214047	TRI STATE TRUCK & EQUIPMENT INC	266	I11-002401	\$ 35.39
6010-31-513-42320	214049	UNITED FIRE SERVICE INC	7841	I11-002742	\$ 661.99
6010-31-513-42290	214051	VALLEY MOTOR SUPPLY CO INC	71	I11-002523	\$ 7.94
6010-31-513-42290	214051	VALLEY MOTOR SUPPLY CO INC	71	I11-002524	\$ 15.88
6010-31-513-42410	214051	VALLEY MOTOR SUPPLY CO INC	71	I11-002595	\$ 25.24
6010-31-513-43410	214055	WCS TELECOM	11222	I11-002358	\$ 6.26
6010-31-513-42320	214057	WHELEN ENGINEERING COMPANY INC	3858	I11-002577	\$ 106.80
6010-31-513-42290	214063	ACE HARDWARE	4876	I11-003110	\$ 5.96
6010-31-513-43640	214075	B & B INDUSTRIAL MACHINE	5051	I11-003109	\$ 20.00
6010-31-513-42290	214077	BARNES DISTRIBUTION	11012	I11-003111	\$ 132.66
6010-31-513-42320	214078	BEARING SALES INC	37	I11-003094	\$ 44.23
6010-31-513-42320	214086	BIG SKY HYDRAULICS & MACHINING INC	11168	I11-003113	\$ 14.50
6010-31-513-42320	214099	CITY MOTOR CO INC	267	I11-002728	\$ 3.89
6010-31-513-42320	214099	CITY MOTOR CO INC	267	I11-003077	\$ 316.85
6010-31-513-42320	214099	CITY MOTOR CO INC	267	I11-003081	\$ -16.68
6010-31-513-42320	214099	CITY MOTOR CO INC	267	I11-003083	\$ -9.14
6010-31-513-42320	214099	CITY MOTOR CO INC	267	I11-003085	\$ 102.02
6010-31-513-42320	214099	CITY MOTOR CO INC	267	I11-003087	\$ -102.02
6010-31-513-42320	214121	FLEET SUPPLY COMPANY	64	I11-003118	\$ 8.99
6010-31-513-42290	214121	FLEET SUPPLY COMPANY	64	I11-003119	\$ 13.48
6010-00-000-15110	214136	I STATE TRUCK CENTER INC	11353	I11-002908	\$ 77.60
6010-31-513-42320	214136	I STATE TRUCK CENTER INC	11353	I11-003121	\$ 26.25

City of Great Falls

Check Details Report (Date: 04/27/2011)

Account#	Check#	VendorName	Vendor#	Invoice#	Amount
6010-31-513-43640	214162	LITHIA OF GREAT FALLS INC	11378	I11-003124	\$ 157.71
6010-31-513-42320	214168	MIDLAND IMPLEMENT COMPANY INC	106	I11-003125	\$ 732.45
6010-31-513-43620	214173	MOUNTAIN CHIME TELEPHONE INC	1065	I11-002767	\$ 117.14
6010-00-000-15120	214175	MOUNTAIN VIEW CO-OP	972	I11-002835	\$ 27,848.79
6010-00-000-15120	214175	MOUNTAIN VIEW CO-OP	972	I11-003102	\$ 31,362.15
6010-31-513-42320	214183	NAPA AUTO PARTS OF GREAT FALLS	68	I11-002761	\$ 10.31
6010-31-513-42290	214183	NAPA AUTO PARTS OF GREAT FALLS	68	I11-002762	\$ 9.38
6010-00-000-15110	214183	NAPA AUTO PARTS OF GREAT FALLS	68	I11-002833	\$ 587.70
6010-00-000-15110	214183	NAPA AUTO PARTS OF GREAT FALLS	68	I11-002834	\$ 53.47
6010-00-000-15110	214183	NAPA AUTO PARTS OF GREAT FALLS	68	I11-002906	\$ 254.31
6010-00-000-15110	214183	NAPA AUTO PARTS OF GREAT FALLS	68	I11-002907	\$ 96.54
6010-31-513-42320	214183	NAPA AUTO PARTS OF GREAT FALLS	68	I11-003088	\$ 113.46
6010-31-513-42320	214183	NAPA AUTO PARTS OF GREAT FALLS	68	I11-003089	\$ 8.69
6010-31-513-42320	214183	NAPA AUTO PARTS OF GREAT FALLS	68	I11-003090	\$ 9.16
6010-31-513-42320	214183	NAPA AUTO PARTS OF GREAT FALLS	68	I11-003091	\$ 3.16
6010-31-513-45390	214184	NATIONAL LAUNDRY	388	I11-003131	\$ 74.48
6010-31-513-42290	214192	OREILLY AUTO PARTS	12052	I11-002760	\$ 259.99
6010-00-000-15110	214192	OREILLY AUTO PARTS	12052	I11-002836	\$ 465.25
6010-00-000-15110	214192	OREILLY AUTO PARTS	12052	I11-002909	\$ 16.79
6010-31-513-42320	214192	OREILLY AUTO PARTS	12052	I11-003065	\$ -30.65
6010-31-513-42320	214193	PACIFIC STEEL	22	I11-003126	\$ 14.00
6010-31-513-42290	214198	PICKWICK'S OFFICE WORKS INC	367	I11-002757	\$ 25.22
6010-31-513-42190	214198	PICKWICK'S OFFICE WORKS INC	367	I11-002758	\$ 78.23
6010-31-513-43620	214198	PICKWICK'S OFFICE WORKS INC	367	I11-002820	\$ 208.67
6010-31-513-43620	214198	PICKWICK'S OFFICE WORKS INC	367	I11-002821	\$ 645.33
6010-31-513-42320	214208	RMT EQUIPMENT	13548	I11-002738	\$ 80.31
6010-31-513-42320	214211	ROCKY MOUNTAIN TRUCK SERVICE INC	9846	I11-003128	\$ 119.80
6010-00-000-15110	214222	SIX ROBBLEES INC	21	I11-002832	\$ 42.33
6010-31-513-42320	214231	TITAN MACHINERY INC	75	I11-003129	\$ 500.22
6010-00-000-15110	214232	TNT SPRINGS INC / TNT TRUCK PARTS	12089	I11-002910	\$ 236.07

City of Great Falls

Check Details Report (Date: 04/27/2011)

Account#	Check#	VendorName	Vendor#	Invoice#	Amount
6010-31-513-42320	214232	TNT SPRINGS INC / TNT TRUCK PARTS	12089	I11-003130	\$ 285.90

				Fund(6010) Total	\$97,950.93

				Grand Total	\$1,321,166.37

CITY OF GREAT FALLS, MONTANA

AGENDA: 11

COMMUNICATION TO THE CITY COMMISSION

DATE: May 3, 2011

ITEM: CONTRACTS LIST
Itemizing contracts not otherwise approved or ratified by City Commission Action
(Listed contracts are available for inspection in the City Clerk’s Office.)

PRESENTED BY: Lisa Kunz, City Clerk

ACTION REQUESTED: Ratification of Contracts through the Consent Agenda

MAYOR’S SIGNATURE: _____

CONTRACTS LIST

	DEPARTMENT	OTHER PARTY (PERSON OR ENTITY)	PERIOD	FUND	AMOUNT	PURPOSE
A	Public Works – Engineering	Lacy & Ebeling Engineering, Inc.	Current		\$1,750	Engineering Services for contract documents, specifications and drawings for coating the 10 th Street Bridge with a protective coating. OF 979.6
B	Police Department	Munroe Enterprise	05/01/2011- 07/30/2011		\$19,300	Contractor Agreement for completion of the GFPD Outdoor Range project. OF 1365.1

C	Fiscal Services	Cascade County Historical Society	Immediate	N/A	N/A	Local Records Transfer Receipt for (2) Concrete Sidewalk Assessment Books (1907-1928)
D	Park and Recreation	Payne Financial	01/2011 – 12/2011	5730-64-642-34603	\$5,000	2011 Ice Breaker Road Race Sponsorship



Item: Construction Contract Award: 11th Street North Utilities Extension/Replacement, O. F. 1556

From: Engineering Division

Initiated By: Public Works Department

Presented By: Jim Rearden, Public Works Director

Action Requested: Consider Bids and Approve Contract

Suggested Motion:

1. Commissioner moves:

"I move the City Commission award a contract in the amount of \$388,883.00 to Phillips Construction LLC for the 11th Street North Utilities Extension/Replacement, O. F. 1556, and authorize the City Manager to execute the construction contract documents."

2. Mayor calls for a second, discussion, inquiries from the public, and calls for the vote.

Staff Recommendation: Approve construction contract award.

Background:

Significant Impacts

This project will extend and replace portions of the water system installed in 1914, and extend the sanitary sewer and storm mains located in 11th Street from River Drive North to 10th Avenue North.

Citizen Participation

This project is being completed in cooperation with the Department of Environmental Quality (DEQ) and local residents and businesses.

Workload Impacts

City engineering staff designed the project and will perform construction inspection and contract administration duties.

Purpose

This project will connect two dead end water mains, which will provide a looped system,

and replace water main that has been failing, damaging roadways and disrupting water service to local residences and businesses. The water main breaks are primarily due to corrosive soils, type of pipe material used, and pipe age.

This project will also extend storm main to alleviate drainage problems in the area, and extend sanitary sewer main which will provide better sewer service access to businesses and eliminate the need to pass beneath Burlington Northerns' railroad tracks.

Project Work Scope

This project will replace approximately 580 lineal feet of 6-inch cast iron water main with 8-inch PVC and install 250 lineal feet of new 8-inch PVC water main, 2 fire hydrants and 4 water service connections; install 635 lineal feet of 21-inch PVC storm main, and 8 inlets; install 330 lineal feet of 8-inch PVC sanitary sewer main; and 3,000 square yards of gravel and 3,000 square yards of four-inch asphalt for road repairs.

The mains to be extended and replaced are located in 11th Street North from River Drive North to 10th Avenue North.

Evaluation and Selection Process

Seven bids were received and opened for this project on April 20, 2011. The bids ranged from \$388,883.00 to \$529,519.00. Phillips Construction LLC submitted the low bid.

Phillips Construction LLC is an established responsible local contractor and has completed many projects within the City. Phillips Construction has the resources and manpower to complete this project.

Conclusion

City staff recommends awarding the contract to Phillips Construction LLC in the amount of \$388,883.00. Phillips Construction has executed all the necessary documents.

Concurrences:

DEQ has reviewed and approved the plans and specifications for this project.

Fiscal Impact:

Replacement of the water main will save on maintenance due to man hours and resources necessary for repairs to broken water mains, streets, and surrounding property. Also extending the storm main will reduce drainage problems in the area and reduce repairs to roadways and property damage.

The attached bid tabulation summarizes bids that were received.

Alternatives:

The City Commission could vote to deny award of the construction contract and re-bid the project or do nothing and continue to repair water main breaks as they occur and repair roadways damaged due to poor drainage.

Attachments/Exhibits:

1. Bid tabulation is attached. (Not available online; on file in City Clerk's Office.)



Item: Construction Contract, Gibson Park Lighting-GTF, O.F. 1595
From: Planning & Community Development / Park & Recreation Department
Prepared By: Marty Basta, Park and Recreation Director
Presented By: Marty Basta, Park and Recreation Director
Action Requested: Consider Bids and Approve Contract

Suggested Motion:

1. Commissioner moves:

"I move the City Commission award a contract in the amount of \$84,653.99 to Liberty Electric, Inc. for the Gibson Park Lighting, O.F. 1595, and authorize the City Manager to execute the necessary documents, contingent upon concurrence from the State of Montana."

2. Mayor calls for a second, discussion, inquiries from the public, and calls for the vote.

Staff Recommendation: Staff recommends that the City Commission approve the bid as submitted by Liberty Electric, Inc. for the Gibson Park Lighting O.F. 1595 in the amount of \$84,653.99.

Background: On June 6, 2008, the City of Great Falls received a letter, from Neighborhood Council #7, regarding the nighttime safety for users of Gibson Park. The council requested that the City install lighting for the Park. The project would provide for the purchase and installation of lights and necessary power supply for lighting of the Gibson Park bicycle and pedestrian path. Several options were explored for funding the project. Park and Recreation staff submitted a Community Transportation Enhancement Program (CTEP) grant request to the Planning Board on June 30, 2009. Of the eight CTEP grant requests submitted for funding, the Gibson Park Lighting project received the top ranking by the Planning Board. The Planning Board recommended approval for funding the project to the State and Federal Highway Administration (FHWA). The project was approved by the City Commission in September of 2009 for funding through the CTEP Program. Notice was received from FHWA in June of 2010 that the Gibson Park Lighting project was approved for funding.

On October 19, 2010 the City Commission approved a contract with Gordon Prill Drapes, Inc. (GPD) consulting for design and construction administration for the Gibson Park Lighting project in an amount not to exceed \$8,000.00.

On April 20, 2011 bids were opened for the lighting project with seven bids submitted. The seven responsive bids ranged from \$84,653.99 to \$113,847. Liberty Electric Inc. submitted the low bid and has executed all of the necessary bid documents. GPD, Inc. evaluated all of the bids and recommends contract award to Liberty Electric, Inc. The scope of work includes installation of 30 LED lights along with necessary electric service. Lighting will include “acorn” style light fixtures and 20-foot steel poles (5 foot imbedded). Electrical work includes installation of circuit breakers, time clock, wiring, trenching, backfill and compaction. The contract also provides for 3 spare fixtures and 1 additional pole.

GPD designed the project, and will perform construction inspection. City Engineering and Planning and Community Development staff will perform contract administration duties, and Park & Recreation staff will monitor park impacts during construction.

Lighting the Gibson Park bicycle and pedestrian path will improve safety for users and increase visibility within the park that may reduce of vandalism.

Final award of the project will be contingent upon Montana Department of Transportation concurrence.

Concurrences:

GPD, Inc. has reviewed the bids and has recommended approval of the selected bidder. City Engineering and Planning staff concurs with the award.

Fiscal Impact:

The attached bid tabulation summarizes bids that were received. The construction will be funded through the Community Transportation Enhancement Program (CTEP), with the required matching funds (13.42%) or \$12,434.17 being provided by donated funds residing in the park Foundation and a matching grant from the Park Trust Fund.

Alternatives:

The City Commission could vote to deny award of the construction contract and re-bid the project or just deny award of the contract.

Attachments/Exhibits:

1. Bid Tabulation Summary is attached.

