



City Commission Agenda

for

September 20, 2011

Please Note: The City Commission agenda format allows citizens to speak on each issue prior to Commission action. We encourage your participation. Please keep your remarks concise and to the topic under consideration.

CALL TO ORDER: 7:00 P.M.

PLEDGE OF ALLEGIANCE

ROLL CALL

PROCLAMATIONS

The Forgotten Five
National Recovery Month
Ursuline Centre Centennial Celebration

NEIGHBORHOOD COUNCILS

1. Miscellaneous reports and announcements from Neighborhood Councils.

BOARDS & COMMISSIONS

2. Miscellaneous reports and announcements from Boards and Commissions.

PUBLIC HEARINGS

3. Res. 9938, to Levy and Assess Properties within Special Improvement Lighting Districts. Action: Conduct public hearing and adopt or deny Res. 9938.
(Presented by: Melissa Kinzler)

OLD BUSINESS

NEW BUSINESS

4. Great Falls Emergency Services request for EMS transport rate increase in accordance with OCCGF 8.9.375. Action: Approve or deny rate increase request. *(Presented by: Randy McCamley)*

ORDINANCES/RESOLUTIONS

5. Ord. 3081, to Assign City Zoning to Service District No. 4 of the Upper/Lower River Road Water & Sewer District. Assigns zoning classification of R-3 Single-family high density district. Action: Accept Ord. 3081 on first reading and set public hearing for October 18, 2011. *(Presented by: Mike Haynes)*

CONSENT AGENDA *The Consent Agenda is made up of routine day-to-day items that require Commission action. Items may be pulled from the Consent Agenda for separate discussion/vote by any Commissioner.*

6. Minutes, September 6, 2011, Commission meeting.
7. Total Expenditures of \$2,298,142 for the period of August 26 through September 14, 2011, to include claims over \$5000, in the amount of \$2,059,033.
8. Contracts list.

9. Grants list.
10. Award bid for one new 2012 tandem axle dump truck to I-State Truck Center of Great Falls in the amount of \$95,871.
11. Award bid for five new section snow plows to Kois Brothers of Great Falls in the amount of \$76,425.
12. Approve Change Order No. 1 in the amount of \$10,112.43 to United Materials of Great Falls for the 21st Avenue NE Drainage Improvements.
13. Approve Change Order No. 1 in the amount of \$6,038 and extend the contract time by 10 days to Dick Olson Construction for the Police Department Rehabilitation CTEP Project.
14. Approve final payment in the amount of \$2,643.11 to Gregoire Construction and the State Miscellaneous Tax Division for the 2010 CDBG Sidewalk Replacement.
15. Approve final payment in the amount of \$64,854.30 to United Materials of Great Falls and the State Miscellaneous Tax Division for the 25th Avenue NE Improvements.

Action: Approve Consent Agenda or remove items for further discussion and approve remaining items.

PETITIONS AND COMMUNICATIONS *(Public comment on any matter that is not on the agenda of the meeting and that is within the jurisdiction of the City Commission. Please keep your remarks to a maximum of 5 minutes. When at the podium, state your name and address for the record.)*

16. Miscellaneous reports and announcements.

CITY MANAGER

17. Miscellaneous reports and announcements from the City Manager.

CITY COMMISSION

18. Miscellaneous reports and announcements from the City Commission.

MOTION TO ADJOURN



Item: Resolution 9938 to Levy and Assess Properties within Special Improvement Lighting District

From: Judy Burg, Fiscal Services Department

Initiated By: Annual Assessment Process

Presented By: Melissa Kinzler, Fiscal Services Director

Action Requested: City Commission conduct public hearing and adopt Resolution 9938

Public Hearing:

1. Mayor conducts public hearing, calling three times each for opponents and proponents.
2. Mayor closes public hearing and asks the will of the Commission.

Suggested Motion:

1. Commissioner moves:

“I move the City Commission (adopt/deny) Resolution 9938.”

2. Mayor calls for a second, discussion, and calls for the vote.
-

Staff Recommendation: Staff recommends the City Commission adopt Resolution 9938 to levy and assess properties within the Special Improvement Lighting Districts.

Background: There are currently 26 Special Improvement Lighting Districts (SLD's) with approximately 9,420 roadway lights, lighting over 70% of the city. The majority, approximately 97%, of the roadway lights are owned by Northwestern Energy. The City of Great Falls pays Northwestern Energy a maintenance fee, an operational fee and a distribution fee for those lights. The electrical supply for the lights is provided by and paid to Electric City Power. The remaining 3% of roadway lighting is City-owned. The Special Improvement Lighting District funds are administered by the Fiscal Services Department. The purpose of the fund is to maintain the light poles and furnish electrical current for the lighting districts throughout the year. After determining financial factors pertinent to the operation of the special improvement lighting districts, an assessment amount for the next fiscal year is calculated, budgeted and presented to the City Commissioners for approval.

As part of the annual budget development and adoption procedures, the Special Improvement Lighting Districts Assessment Resolution must be submitted for City Commission action. A public notice and hearing is required prior to final passage of the assessment resolution.

Concurrences: Fiscal Services staff is responsible for the operational expenses, along with assessing and collecting the revenues; Public Works is responsible for the maintenance of all City-owned lighting districts.

Fiscal Impact: Adoption of Resolution 9938 will allow the City to fund the operational and maintenance costs required to be made each year in the Special Improvement Lighting Districts.

ASSESSMENT ANTICIPATED

The anticipated assessment amount for the Special Improvement Lighting District funds for the next fiscal year is the amount projected through the budget development process. The maintenance and administrative fee equal to 10% of the estimated costs for the districts as presented in the annual budget will remain the same. The ONE MILLION SEVEN HUNDRED SIXTY-SIX THOUSAND SIX HUNDRED FORTY DOLLARS (\$1,766,640) estimated assessment for Fiscal Year 11/12 projects charges based on actual billings for the districts and adjustments for cash balances from prior fiscal years.

<u>BUDGETED</u>	<u>FISCAL YEAR</u>
<u>TOTAL ASSESSMENT</u>	
\$1,180,235	07/08 (22 Districts) ¹
\$1,277,587	08/09 (24 Districts) ²
\$1,390,777	09/10 (26 Districts)
\$1,595,981	10/11 (26 Districts)
\$1,766.640	11/12 (26 Districts)

¹ Two new City-owned Residential Lighting Districts were created in FY 07/08 – Special Improvement Lighting Districts No. 1308 and No. 1310

² Two new City-owned Residential Lighting Districts were created in FY 08/09 – Special Improvement Lighting Districts No. 1303 and No. 1305. Minor modifications to Special Improvement District 1295 – Commercial Lighting District (SLD-C) – two lights were removed and Special Improvement Lighting District No. 1269 – four new lights were added to the district.

The 11/12 assessment per district is indicated on the SLD Cost Assessment Projection Sheet attached as Exhibit “A” and made a part of Resolution 9938.

Alternatives: The City Commission could choose to deny the adoption of Resolution 9938; however, the reduction in services to the community could be hazardous to the safety and welfare of the general public.

Attachments/Exhibits: Resolution 9938
 Exhibit “A” SLD Cost Assessment Projection Sheet
 SLD’s Boundary Map

RESOLUTION 9938

A RESOLUTION LEVYING AND ASSESSING THE COST OF MAINTAINING SPECIAL IMPROVEMENT LIGHTING DISTRICTS (SLD's) NUMBERED 18, 650, 651, 912, 973, 1067A, 1105, 1230, 1255, 1261, 1269, 1270, 1289, 1290, 1294, 1295, 1296, 1297, 1298, 1302, 1303, 1304, 1305, 1306, 1308 AND 1310 IN THE CITY OF GREAT FALLS, MONTANA FOR THE FISCAL YEAR BEGINNING JULY 1, 2011 AND ENDING JUNE 30, 2012

WHEREAS, the City Commission of the City of Great Falls declares the lighting systems were installed and the City Commission intends to continue maintenance of such lighting systems in said SLD's;

WHEREAS, the City Commission of the City of Great Falls declares that each lot or parcel of land contained in each of said SLD's will continue to be benefited by such lighting in the same manner as determined in the creation of each district;

WHEREAS, on July 19, 2011, the Commission of the City of Great Falls adopted its annual budget resolution in which the estimated costs of such lighting system maintenance within said SLD's at a total of ONE MILLION SEVEN HUNDRED SIXTY-SIX THOUSAND SIX HUNDRED FORTY DOLLARS (\$1,766,640);

WHEREAS, the properties in said SLD's are to be assessed for the ongoing annual maintenance costs of said improvements in proportion to which its area bears to the area of the district improved, as determined by the square foot method.

NOW, THEREFORE, BE IT RESOLVED BY THE CITY COMMISSION OF THE CITY OF GREAT FALLS, MONTANA:

Section 1 – Continued Maintenance

The City of Great Falls continue maintenance of lighting systems in said special improvement lighting districts (SLD's).

Section 2 – Maintenance Costs Assessed

The estimated cost of said lighting system maintenance in the SLD's totaling ONE MILLION SEVEN HUNDRED SIXTY-SIX THOUSAND SIX HUNDRED FORTY DOLLARS (\$1,766,640) is hereby assessed upon the properties in said SLD's.

Section 3 – Assessment Method

Each lot and parcel within each SLD is hereby assessed a proportion of the maintenance costs attributed to the SLD in the proportion to which its assessable area (individual square feet) bears

to the area of the whole special improvement lighting district (total square feet), exclusive of streets, avenues, alleys and public places. An assessment projection summary of each district, describing total cost, is attached hereto and by this reference incorporated herein as set forth in full. The description of each lot or parcel of land within each SLD and the respective assessments are set forth in the records of the Fiscal Services Office of the City of Great Falls, Montana and by this reference is also incorporated herein as if set forth in full;

Section 4 – Assessments Due Date

The ongoing annual maintenance assessments are payable in two payments and will become delinquent at 5:00 o'clock p.m. on November 30, 2011 and May 31, 2012.

NOW, THEREFORE, BE IT FURTHER RESOLVED BY THE COMMISSION OF THE CITY OF GREAT FALLS, MONTANA:

THAT, the City Commission did meet and hear objections to the final adoption of this resolution at 7:00 o'clock p.m., September 20, 2011 in the Commission Chambers of the Civic Center Building, Great Falls, Montana.

THAT, this resolution, together with the attached Exhibit "A", shall be kept on file in the office of the City Clerk of the City of Great Falls.

THAT, said City Clerk is authorized and directed, to publish twice, with at least 6 days separating each publication in a newspaper published in the City of Great Falls, Montana, a notice stating that this resolution, levying the special assessments to defray the cost of maintenance of said SLD's, is subject to inspection in the City Clerk's office, 2 Park Drive, Room 204, Great Falls, Montana. Said notice shall state the time and place at which objections to the final adoption of this resolution will be heard by the City Commission.

NOW, THEREFORE, BE IT FURTHER RESOLVED that the above-entitled and foregoing resolution be, and the same is hereby adopted, and the special assessments therein provided for, and the same are hereby levied and assessed accordingly.

PASSED by the Commission of the City of Great Falls, Montana, on this 20th day of September 2011.

Michael J. Winters, Mayor

ATTEST:

Lisa Kunz, City Clerk

(SEAL OF CITY)

APPROVED FOR LEGAL CONTENT:

James W. Santoro, City Attorney

RESOLUTION #9938 - EXHIBIT "A"
CITY OF GREAT FALLS

STREET LIGHT MAINTENANCE DISTRICTS

COST ASSESSMENTS PROJECTIONS

TAX YEAR 2011

Res 9938 Street Maintenance Assessment			2010 DISTRICT ASSESSMENTS	ASSESSMENT CHANGE		DISTRICT SQUARE FEET		SQUARE FEET DIFFERENCE	ASSESSMENT FACTORS	
DISTRICT NUMBER	FUND #	2011 TARGET ASSESSMENT		AMOUNT	PERCENT	2010	2011		2010	2011
18	2402	2,751	2,751.72	-0.72	-0.03%	1,606,323	1,606,323	0	0.001713	0.001713
650	2403	22,327	19,935.04	2,391.96	12.00%	500,107	500,107	0	0.039861	0.044644
651	2404	2,957	2,688.12	268.88	10.00%	546,204	546,204	0	0.004921	0.005414
912	2405	15,580	15,581.06	-1.06	-0.01%	7,017,882	7,017,677	-205	0.002220	0.002220
973	2406	483	482.66	0.34	0.07%	5,027,275	5,027,275	0	0.000096	0.000096
1105	2408	4,263	4,013.50	249.50	6.22%	1,986,605	1,986,605	0	0.002020	0.002146
1230	2409	237	237.12	-0.12	-0.05%	105,053	105,053	0	0.002256	0.002256
1255	2410	483	483.00	0.00	0.00%	235,098	235,098	0	0.002054	0.002054
1261	2411	5,950	4,399.62	1,550.38	35.24%	340,475	340,475	0	0.017476	0.017476
1269	2412	35,924	26,295.84	9,628.16	36.61%	659,823	659,821	-2	0.039852	0.054445
1270	2413	11,917	11,917.18	-0.18	0.00%	224,990	224,990	0	0.052967	0.052967
1289	2414	16,863	15,331.68	1,531.32	9.99%	3,328,593	3,328,585	-8	0.004606	0.005066
1290	2415	1,291	1,091.18	199.82	18.31%	278,694	278,694	0	0.003915	0.004632
1067A	2407	5,541	5,540.84	0.16	0.00%	1,505,636	1,505,634	-2	0.003680	0.003680
1302	2430	6,560	5,100.18	1,459.82	28.62%	189,158	189,158	0	0.026962	0.034680
1303	2440	3,878	3,878.22	-0.22	-0.01%	231,889	231,889	0	0.016724	0.016724
1304	2432	10,151	7,898.16	2,252.84	28.52%	843,150	843,150	0	0.009367	0.012039
1305	2442	2,691	2,691.10	-0.10	0.00%	216,649	216,649	0	0.012421	0.012421
1306	2434	1,836	1,836.16	-0.16	-0.01%	188,910	188,910	0	0.009719	0.009719
1308	2436	4,409	4,409.12	-0.12	0.00%	451,932	451,932	0	0.009756	0.009756
1310	2438	3,259	2,850.16	408.84	14.34%	212,186	212,186	0	0.013432	0.015359
1294	2416	153,129	139,217.60	13,911.40	9.99%	82,995,100	83,002,952	7,852	0.001677	0.001845
1295	2418	71,908	65,374.42	6,533.58	9.99%	4,029,092	4,029,198	106	0.016225	0.017847
1298	2417	33,709	21,097.24	12,611.76	59.78%	5,109,456	5,109,456	0	0.004129	0.006597
1296	2419	1,311,155	1,191,958.02	119,196.98	10.00%	130,263,072	130,283,808	20,736	0.009150	0.010064
1297	2420	37,388	37,390.10	-2.10	-0.01%	2,654,541	2,654,541	0	0.014085	0.014085
TOTAL		1,766,640	1,594,449.04	172,191		250,747,893	250,776,370	28,477	0.012357	0.013844
					11%				average inc	12%

-  STREET DEPARTMENT
-  SINGLE UNDERGROUND STEEL
-  SINGLE OVERHEAD STEEL
-  DEDICATED WOOD
-  DISTRIBUTION WOOD POLE
-  FIBERGLASS POLES
-  FIVE GLOBE PERIOD LIGHTS
-  THREE GLOBE PERIOD LIGHTS
-  ANTIQUE LUMINAIRE
-  TRAFFIC SIGNAL STEEL POLE

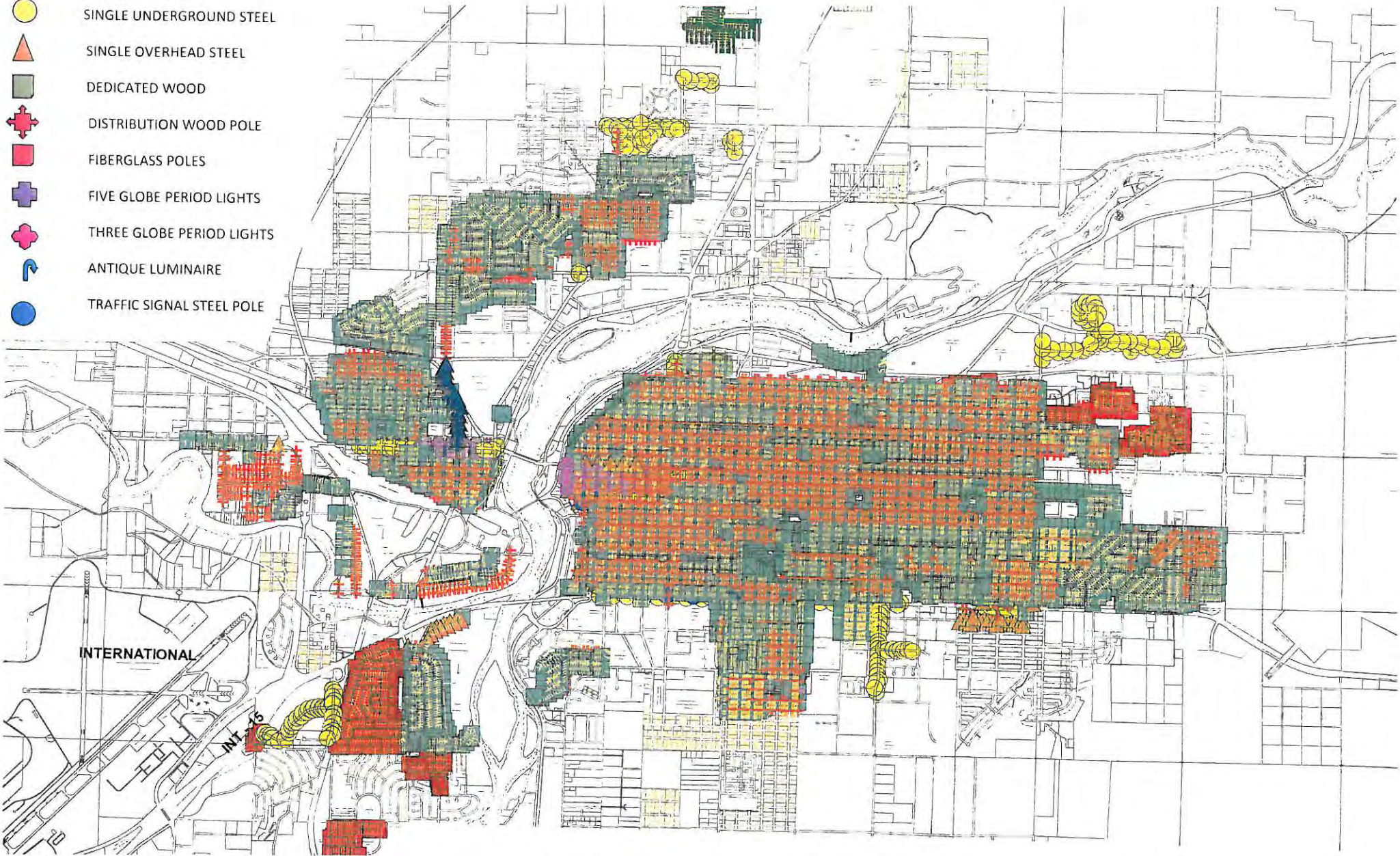

A MORE DETAILED AND LARGER VERSION OF THIS MAP IS AVAILABLE IN THE OFFICE OF FISCAL SERVICES



**CITY OF GREAT FALLS
COMMISSION AGENDA REPORT**

Item: Great Falls Emergency Services request for EMS transport rate increase in accordance with OCCGF 8.9.375.

From: Randall E. McCamley, Fire Chief/City EMS Administrator.

Initiated By: Dave Kuhn, President Great Falls Emergency Services.

Presented By: Randall E. McCamley, Fire Chief.

Action Requested: Approve or deny proposed EMS rate increases for Great Falls Emergency Services EMS transport.

Suggested Motion:

1. Commissioner moves:

“I move the City Commission (approve/deny) increases in transport rates as per Great Falls Emergency Services proposal and found in Exhibit D-1, Addendum to the EMS Transport Services Contract.”

2. Mayor calls for a second, discussion, inquiries from the public, and calls the vote.

Background

In 2008 the City of Great Falls entered into an EMS Transport Services contract with Great Falls Emergency Services. OCCGF 8.9.375 allows for rate increases “if said fees are consistent with industry best practices, the market, and applicable federal and state laws.”

Significant Impacts

Ambulance rate increases will have a direct impact on citizens who receive prehospital Emergency Medical Services (EMS) from Great Falls Emergency Services (GFES).

Citizen Participation

GFES is a private business that provides EMS transport to the city and county citizens and therefore hasn't gone through the normal public participation process. Mr. Kuhn hasn't requested this proposal be presented to the EMS Advisory Board for review, nor is this a requirement for a rate increase. Because of the EMS contract and City ordinance the EMS transport contractor must receive City Commission approval for any rate increases.

Workload Impacts

Staff does not anticipate a workload increase as a result of approving the rate increase as proposed.

Purpose

According to the EMS City ordinance, increases to the EMS transport contractor's fees must be submitted to the Commission for approval.

According to GFES's proposal and comments, the fee increases are necessary to maintain the company's financial stability and to continue to provide critical 911 transport service in the City of Great Falls.

Staff finding and recommendation

To determine the appropriateness of the proposed ambulance rate increases, staff has reviewed ambulance rate increase information provided by Mr. Dave Kuhn. Based on the information provided, it appears a rate adjustment is necessary to ensure the financial stability and vitality of Great Falls Emergency Services business operations. It must be noted due to the confidentiality of many of the private ambulance providers rate structure, it was difficult for staff to verify all the data provided by GFES.

According to Mr. Kuhn, the basis for the proposed rate increase is to make up for losses incurred by "substantial reduction in revenue and volume from Benefis intra-facility transports." This loss of revenue to Great Falls Emergency Services is reported to be considerable and is creating a hardship on our contracted transport provider. Staff has been informed by Mr. Kuhn that without a rate increase the continuance of his transport service may be in question.

Staff recognizes and supports the need to periodically increase ambulance rates to maintain financial health and vitality of GFES. Staff does have a general concern with raising 911 ambulance rates due to a change in business practices not related to 911 emergency ambulance services.

Based on the data presented to staff, it appears rate increases are within market and are warranted. Staff does recommend the City Commission approve the proposed rate increases with concerns noted.

Evaluation and Selection Process

Staff has reviewed the GFES proposal and has submitted GFES proposal as written.

Conclusion

As noted there is provision within the EMS transport in OCCGF 8.9.375 to allow fee increases that reads as follows; "The contracted ambulance service shall submit to the EMS administrator a proposed ambulance fee schedule that will be approved by the City Commission if said fees are consistent with industry best practices, the market, and applicable federal and state laws."

Concurrences:

EMS administrator

City Manager's Office
City Attorney

Fiscal Impact:

See "significant impacts"

Alternatives:

Deny changes to the current transport fees. Denial of rate increases may result in discountenance of GFES services which would force the City to identify alternate EMS transport options.

Attachments/Exhibits:

Great Falls Emergency Services proposal
Exhibit D-1, Addendum to the EMS Transport Services Contract

GREAT FALLS EMERGENCY SERVICES

Summary:

Over the years Great Falls Emergency Services (GFES) has been able to keep its emergency transport rates below average. Recently GFES experienced a substantial reduction in revenue and volume from Benefis for intra-facility transports. This reduction in volume has reduced GFES' total annual transport volume by over 15%. GFES must now increase its rates to market.

Although most companies do not like to share rate information we have done a market analysis and have found that the average ALS emergent **base** rate for 6 private service providers in Montana averages \$963. However, the true market rate for an ALS transport in Great Falls is between \$1,017 and \$1,075 (See attached Rate Comparisons 2011).

According to the city ordinance, GFES is required to request a rate increase and if proposed rates are consistent with the market then the City Commission will approve said fees. The last GFES base rate increase was in November 2008. Therefore, GFES presents the following rate increase to the EMS Administrator.

Rate Increases starting on October 1, 2011

	<u>Current Rate</u>	<u>Proposed Rate</u>	<u>% Increase</u>
ALS emergent rate	\$847	\$997	17.8%
BLS emergent rate	\$695	\$849	22.2%
ALS 2 rate	\$997	\$997	0%
Mileage	\$15.25	\$19.75	29.5%
Oxygen	\$49.50	\$69.50	
IV Supplies	\$39.00	\$59.00	
ALS routine supplies	\$59.50	\$79.50	
BLS routine supplies	\$39.50	\$59.50	
Intubation Supplies	\$85.00	\$85.00	
Defibrillation Supplies	\$69.00	\$69.00	
EKG supplies	\$8.50	\$12.50	
Medications	Market Rate	Market Rate	

Price increase will only impact those that are self pay or have private insurance. Medicare, Medicaid, VA, etc. have set government rates. GFES works with individuals that do not have the ability to pay. The only customers that should experience a price increase are those that have private health insurance, which only represents approximately 15% to 16% of GFES transports.

Example of a comparable private company that pays similar city fees as GFES

Description	Unit Charge	Units	Total Charge
ALS1 Emergency	983.60	1	983.60
Mileage	20.71	18	372.78
*Decontamination	60.55	1	60.55
*ALS Personal Care	68.32	1	68.32
IV Admin Supply	62.11	1	62.11
Solution	22.50	1	22.50
*Pulse Ox Probe	91.78	1	91.78
*Minor Dressing ALS	31.24	1	31.24
*Cold Pack ALS	14.71	1	14.71
TOTAL DUE			\$1,707.59

*Items (\$266.60) that are included in GFES' ALS supply rate of \$79.50.

GFES total charges - new rates

Description	Unit Charge	Units	Total Charge
ALS1 Emergency	997.00	1	997.00
Mileage	19.75	18	355.50
ALS Supplies	79.50	1	79.50
IV Supplies	59.50	1	59.50
Meds	24.11	1	24.11
TOTAL DUE			\$1,515.61
RATE DIFFERENCE			(\$191.98)

City Ordinance "8.9.375 Ambulance service rates.

A. The contracted ambulance service shall submit to the EMS administrator a proposed ambulance fee schedule that will be approved by the City Commission if said fees are consistent with industry best practices, the market, and applicable federal and state laws.

B. The ambulance service may not refuse transport based on the patient's inability to pay.

PROPOSED EXHIBIT D-1

Addendum to the EMS Transport Services Contract

Advanced Life Support	Current Rate	Proposed Rate Effective 10/1/2011
ALS Emergent Rate	\$847.00	\$997.00
ALS 2 Emergent Rate	\$997.00	\$997.00
Wait Time	No Charge	No Charge
Night Charge	No Charge	No Charge
ALS Treatment w/o transport	No charge	No Charge
Oygen	\$49.50	\$69.50
IV Supplies	\$39.00	\$59.00
ALS Routine Supplies	\$59.50	\$79.50
Intubation Supplies	\$85.00	\$85.00
Defibrillation Supplies	\$69.00	\$69.00
EKG Supplies	\$8.50	\$12.50
Mileage	\$15.25	\$19.75
Medications	Market Rate	Market Rate
Basic Life Support	Current Cost	Proposed Rate
BLS Emergency	\$695.00	\$849.00
Night Charge	No Charge	No Charge
BLS Treatment w/o Transport	No Charge	No Charge
Waiting Time	No Charge	No Charge
Oygen	\$49.50	\$69.50
BLS Routine Supplies	\$39.50	\$59.50
EKG Supplies	\$8.50	\$12.50
Mileage	\$15.25	\$19.75

Note:

1) 34% of all calls are considered treatment without transport or cancels for which GFES has chosen not to charge.

2) GFES' collection rate is approximately 49% on the other 66% of calls. The low collection rate can be attributed to reimbursement from Medicare, Medicaid, no pay, and selfpay, which makes up the majority of GFES' transports.



Item: Ordinance 3081 to Assign City Zoning to Service District No. 4 of the Upper/Lower River Road Water & Sewer District

From: Jana Cooper, RLA, Planner II

Initiated By: Upper/Lower River Road Water & Sewer District Board and Property Owners within Service District No. 4

Presented By: Mike Haynes, AICP, Director of Planning and Community Development

Action Requested: City Commission accept Ordinance 3081 on first reading and set a public hearing for October 18, 2011, to consider adoption of Ordinance 3081

Suggested Motion:

1. Commissioner moves:

“I move that the City Commission (accept/deny) Ordinance 3081 on first reading and set a public hearing for October 18, 2011.”

2. Mayor calls for a second, discussion, inquiries from the public, and calls the vote.

Recommendation: At the conclusion of a public hearing held July 26, 2011, the Zoning Commission passed a motion recommending the City Commission assign City zoning classifications of R-3 Single-family high density district to the various properties within Upper/Lower River Road Water and Sewer Service District (ULRRWSD) No. 4. The recommendation was based on current County zoning, size of lots, existing land uses on the properties and consistency with previous assignment of zoning to properties on 32nd Ave N.

The Planning Advisory Board passed a motion recommending the City Commission annex the subject property into the City of Great Falls, subject to compliance with the Memorandum of Understanding dated July 19, 2011 between the City and the ULRRWSD. Staff recommended approval of both the annexation and zoning. No citizens spoke at the public hearing for or against the project.

Background: The Upper/Lower River Road Water & Sewer District is proposing to annex into the City of Great Falls Service District No. 4, located in Section 24, Township 20 North, Range 3 East, Cascade County, Montana. The subject property boundary includes parcels in the Southvale Addition and portions of 31st Avenue South, 32nd Avenue South and 3rd Street South. The subject property consists of approximately 16.6 acres, containing 57 parcels and involving 27

different owners. For additional information, please refer to the attached exhibits Vicinity/Zoning Map and Aerial Photo.

Beginning in 1996, the Cascade County City-County Health Department and State Department of Environmental Quality initiated an 18-month groundwater pollution study in the Upper and Lower River Road and Donovan Park areas. The subject area is occupied by about 3,000 residents and is the largest area in Cascade County with this type of density having neither a public water nor sewage system.

No imminent health hazards were found as a result of the study. However, it was determined that impacts to the area groundwater were being caused from individual sewage septic systems and two aging sewage lagoons serving the Pearson Addition and the Trailer Terrace Mobile Home Court in the Donovan Park area. The study recommended area residents alleviate potential public health problems by developing an official sewer and water district in order to be eligible for state and federal grants for the planning and construction of public water and sewer systems for subject area. In addition, such a district would have contracting authority for any interlocal agreements that might be possible with the City of Great Falls for connection to City water and sewer lines already present in a portion of the study area.

The study was divided into two separate geographic areas (Upper/Lower River Road and Donovan Park). Although problems were noted during the study in both areas, the worst problems were noted in the northern portion of the study area along Upper/Lower River Road, and therefore, focus was directed to correcting the problems in that area. The Donovan Park area is generally located a mile and a half south of the Upper/Lower River Road area.

In 2001, property owners along Upper/Lower River Roads voted to create a water and sewer district and subsequently elected a five-member board of directors to find the best solutions to the water and sewer problems and the money to pay for it. The District and the City entered into a Memorandum of Understanding dated August 19, 2003, wherein, it was noted the most cost effective manner of providing water and sewer services to serve the District was to connect to the City's water and sewer systems, thereby requiring annexation to the City.

In November, 2003, voters in the defined District, roughly bounded by the Missouri River, 41st Avenue South, 4th Street South, and the city limit at 19th Avenue South, defeated a \$5.7 million bond to pay for extension of City water and sewer lines into the area. Subsequently, and to reduce the per household cost of the project, the District was divided into smaller service areas. Service Districts No. 1, No. 2 and No. 3 have already been designed and constructed.

Annexation of Service District No. 1 was approved by the City Commission on March 6, 2007. Annexation of Service District No. 2 was approved by the City Commission on May 5, 2009. Annexation of Service District No. 3 was approved by the City Commission on November 16, 2010.

Similar to Service District No. 1, No. 2 and No. 3 of the ULRRWSD, the Board and the City entered into a Memorandum of Understanding dated July 19, 2011, wherein, it was noted, again, the most cost effective manner of providing water and sewer services to serve Service District No. 4 was to connect to the City's water and sewer systems, thereby requiring annexation to the City.

The City will continue previous Interlocal Agreements that specifically address the implementation of the construction of the water and sewer improvements, how properties will be connected, how annexation will occur, and other related matters.

Annexation Request

As a prerequisite to obtaining City water and sewer services, property owners in Service District No. 4 were required to sign several documents, including an annexation petition. The City has received signed petitions from the owners of a majority (more than 50%) of the parcels in Service District No. 4. All of the parcels within Service District No. 4 are being annexed under rules of MCA Section 7-2-4601. As such, if the City has received a written petition containing a description of the area requested to be annexed that is either signed by more than 50% of the resident electors owning real property in the area to be annexed; or by the owners of 50% of the real property in the area to be annexed, then the governing body may approve the annexation by adopting a resolution.

Zoning Analysis

It is proposed City zoning classification of R-3 Single-family high density district be assigned to the various properties within said Service District No. 4. This classification is based on current County zoning, existing lot size and current land-uses upon the subject properties.

Section 76-2-304 Montana Code Annotated lists criteria and guidelines which must be considered in conjunction with rezoning and establishing municipal zoning on land including:

- designed in accordance with the growth policy (comprehensive plan);
- will secure safety from fire and other dangers;
- will promote public health, public safety and the general welfare;
- will facilitate the adequate provision of transportation, water, sewerage, schools, parks and other public requirements;
- will provide adequate light and air;
- will consider the effect on motorized and non-motorized transportation systems;
- will promote compatible urban growth;
- will give reasonable consideration to the character of the district;
- gives reasonable consideration to the peculiar suitability for particular uses;
- will conserve the value of buildings; and
- will encourage the most appropriate use of land throughout the municipality.

The proposed zoning of the subject property recognizes and conforms to existing land uses on the parcels proposed to be annexed and will not, without processing of separate applications, result in additional development. Existing legal land uses, which are not permitted by right in the proposed zoning classification to be assigned to the properties, will continue to be recognized and allowed as legal nonconforming uses.

The proposed City zoning to the predominately developed areas coincides with few exceptions to existing County zoning designations. Therefore, staff concludes the above-cited criteria are substantially met.

The Environmental Element of the City of Great Falls Growth Policy notes that the only significant groundwater problem in the immediate vicinity of Great Falls is located near Upper/Lower River Road and advocates finding an acceptable solution to the groundwater problems. A goal of the Environmental Element is “To maintain and improve the quality of the area’s air and water, even as the community grows.”

Goals of the Land Use Element of the City Growth Policy include:

- To support and encourage efficient, sustainable development and redevelopment throughout the community.
- To preserve and enhance the character, quality, and livability of existing neighborhoods.
- To support and encourage a compatible mix of land uses in newly developing areas.

Annexation of subject property will enhance health, safety and welfare through application of City Codes and provision of municipal services.

Infrastructure

Roads in the subject area are not built to City standards. They are currently unpaved and have no curb, gutter or sidewalks. At this time the City is not requiring any improvements to the existing streets. The City is not obligated, as part of this annexation, to bring streets in the subject area to City Code. The requested annexation and zoning does not include a proposal for any new development; therefore, it is reasonable to assume that there would be no increased traffic demands caused by this request.

There is an existing regional sewer line, the Northwest interceptor located in 31st Avenue South. This sewer is not a part of the ULRRWSD No. 4 and will not be utilized by property owners in District No. 4 for sewer services.

City water and sewer mains shall be extended in 31st Avenue South from Upper River Road east to the edge of the subject property servicing properties north and south of 31st Avenue South. City water and sewer will also be extended from their existing locations in 32nd Avenue South east to the edge of the subject property servicing the properties located north and south of 32nd Avenue South. There are no existing storm drain facilities in any of the ULRRWSD Areas and District No. 4 will not have storm drain either.

The City will not require residents of Service District No. 4 to waive their right of protest for future special improvement districts for roadway, street lighting, and storm drain improvements. It is mutually agreed and understood that the District will not be involved in formation of roadway, storm drain, lighting, or other Special Improvement Districts. Nothing herein obligates the City to upgrade or improve roadways within the District.

The City has committed to investing in the infrastructure improvements to the ULRRWSD; the City has dedicated a minimum of \$1 million in City CDBG funds to defray the cost of construction of the Improvements for HUD eligible District residents. To date the City has spent \$333,000 of the \$1 million for the cost of construction in Service District No. 1 and \$332,000 of the \$1 million for the cost of construction in Service District No. 2. The City’s CDBG contribution for Service district No. 4 shall be \$332,000, which the City Commission has already committed. In addition, the City will endorse and support all District efforts for future funding of the Project, will utilize no interest “deferred payment” CDBG housing rehab funds to assist in

income eligible residents in meeting life safety codes and / or constructing utility service lines and the City will bear the cost of over-sizing of all water and sewer pipelines in the District that are required for future growth to the south, east and west of the District as determined by the City.

Conclusion

The proposed annexation of Service District No. 4 of the ULRRWSD is the culmination of a 15 year process to address public health and utility service problems in the area. Annexation will bring the involved area into compliance with City policies and codes regarding provision of such services. However, it should be recognized and understood that the City, by accepting and approving the annexation, is incurring significant responsibilities and liabilities. Some public infrastructure, including roadways, paving, curbs, gutters, sidewalks, and storm sewer/drainage is nonexistent or substandard. There are undoubtedly several instances of buildings not complying with City building codes, mobile homes not complying with current applicable design standards or yards not complying with property improvement standards. However, to require full compliance at the time of annexation could create extreme hardship for property owners and could jeopardize the ability to ever annex these properties. Therefore, per a Memorandum of Understanding between the City and the ULRRWSD, the City has agreed to phase in additional improvements and code compliance requirements involving a schedule and financial plan acceptable to the property owners. Additionally, the area will progress over time as owners' seek to improve their properties consistent with City code and standards.

It is anticipated the City Commission, following the public hearing on October 18, 2011, will consider the annexation resolution simultaneously with Ordinance 3081.

Concurrences: Representatives from the City's Public Works, Park and Recreation and Fire Departments have been involved throughout the review and approval process for this project.

Fiscal Impact: Please refer to the Conclusion section which explains the responsibilities and liabilities the City is incurring in conjunction with this annexation.

Alternatives: The City Commission could deny acceptance of Ordinance 3081 on first reading and not set the public hearing. However, such action would deny the ULRRWSD Board and property owners within Service District No. 4 due process and consideration of a public hearing, as provided for in City Code and State Statute. The City Commission has already committed the \$332,000 toward infrastructure construction costs for Service District No. 4.

Attachments/Exhibits:

- Vicinity/Zoning Map
- Aerial Photo
- Ordinance 3081 with Exhibit A

Cc: Jim Rearden, Public Works Director
Dave Dobbs, City Engineer
Marty Basta, Park and Recreation Director
Melissa Kinzler, Fiscal Services Director
Lyle Meeks, Neil Consultants, 4509 North Star Blvd, 59405
John Stephenson-Love, 300 Central Ave, 7th Floor, 59401
Susan Conell, Cascade County Planning Department, 121 4th St N, Great Falls MT 59404

ORDINANCE 3081

AN ORDINANCE ASSIGNING A ZONING CLASSIFICATION OF R-3 SIGLE-FAMILY HIGH DENSITY DISTRICT TO SERVICE DISTRICT NO. 4, LOCATED IN SECTION 24, TOWNSHIP 20 NOTRH, RANGE 3 EAST, CASCADE COUNTY, MONTANA TO BE KNOWN AS SERVICE DISTRICT NO. 4.

* * * * *

WHEREAS, numerous property owners along Lower and Upper River Roads in Section 24, Township 20 North, Range 3 East, P.M.M., Cascade County, Montana, have elected to create a water and sewer district known as the Upper/Lower River Road Water & Sewer District; and,

WHEREAS, more than fifty per cent (50%) of the 27 property owners within what is described as Service District No. 4 of the Upper/Lower River Road Water & Sewer District have executed and submitted applications to annex their properties to the City of Great Falls; and,

WHEREAS, the Great Falls Zoning Commission, at the conclusion of a public hearing held July 26, 2011, passed a motion recommending the City Commission of the City of Great Falls assign zoning classifications of R-3 Single-family high density residential district to the properties within said Service District No. 4 being annexed to the City of Great Falls, as depicted on the zoning map attached hereto as Exhibit "A" and by this reference made a part hereof.

WHEREAS, notice of assigning zoning classifications of R-3 Single-family high density, to the portion of Service District No. 4 within the Upper/Lower River Road Water Sewer District being annexed to the City, was published in the Great Falls Tribune advising that a public hearing on this zoning designation would be held on the 18th day of October, 2011, before final passage of said Ordinance herein; and,

WHEREAS, following said public hearing, it was found and recommended that the said zoning designations be made,

NOW THEREFORE, BE IT ORDAINED BY THE COMMISSION OF THE CITY OF GREAT FALLS, STATE OF MONTANA:

Section 1. It is determined that the herein described zoning designation will meet the criteria and guidelines cited in Section 76-2-304 Montana Code Annotated, and Section 17.16.40.030 of the Unified Land Development Code of the City of Great Falls.

Section 2. That the zoning of Service District No. 4 of the Upper/Lower River Road Water & Sewer District, be designated as R-3 Single-family high density district as depicted on the attached Exhibit "A".

Section 3. This ordinance shall be in full force and effect either thirty (30) days after its passage and adoption by the City Commission or upon filing in the office of the Cascade County Clerk and Recorder the resolution annexing Service District No. 4 of the Upper/Lower River Road Water & Sewer

District, into the corporate limits of the City of Great Falls, Montana, whichever event shall occur later.

APPROVED by the City Commission of the City of Great Falls, Montana, on first reading September 20, 2011.

Michael J. Winters, Mayor

ATTEST:

Lisa Kunz, City Clerk

(CITY SEAL)

APPROVED FOR LEGAL CONTENT:

James W. Santoro, City Attorney

State of Montana)
County of Cascade : ss
City of Great Falls)

I, Lisa Kunz, City Clerk of the City of Great Falls, Montana, do hereby certify that I did post, as required by law and as prescribed and directed by the City Commission, Ordinance 3081 in three conspicuous places within the limits of said City to-wit:

- On the Bulletin Board, first floor, Civic Center Building;
- On the Bulletin Board, first floor, Cascade County Court House;
- On the Bulletin Board, Great Falls Public Library

(CITY SEAL)

Lisa Kunz, City Clerk

Exhibit A

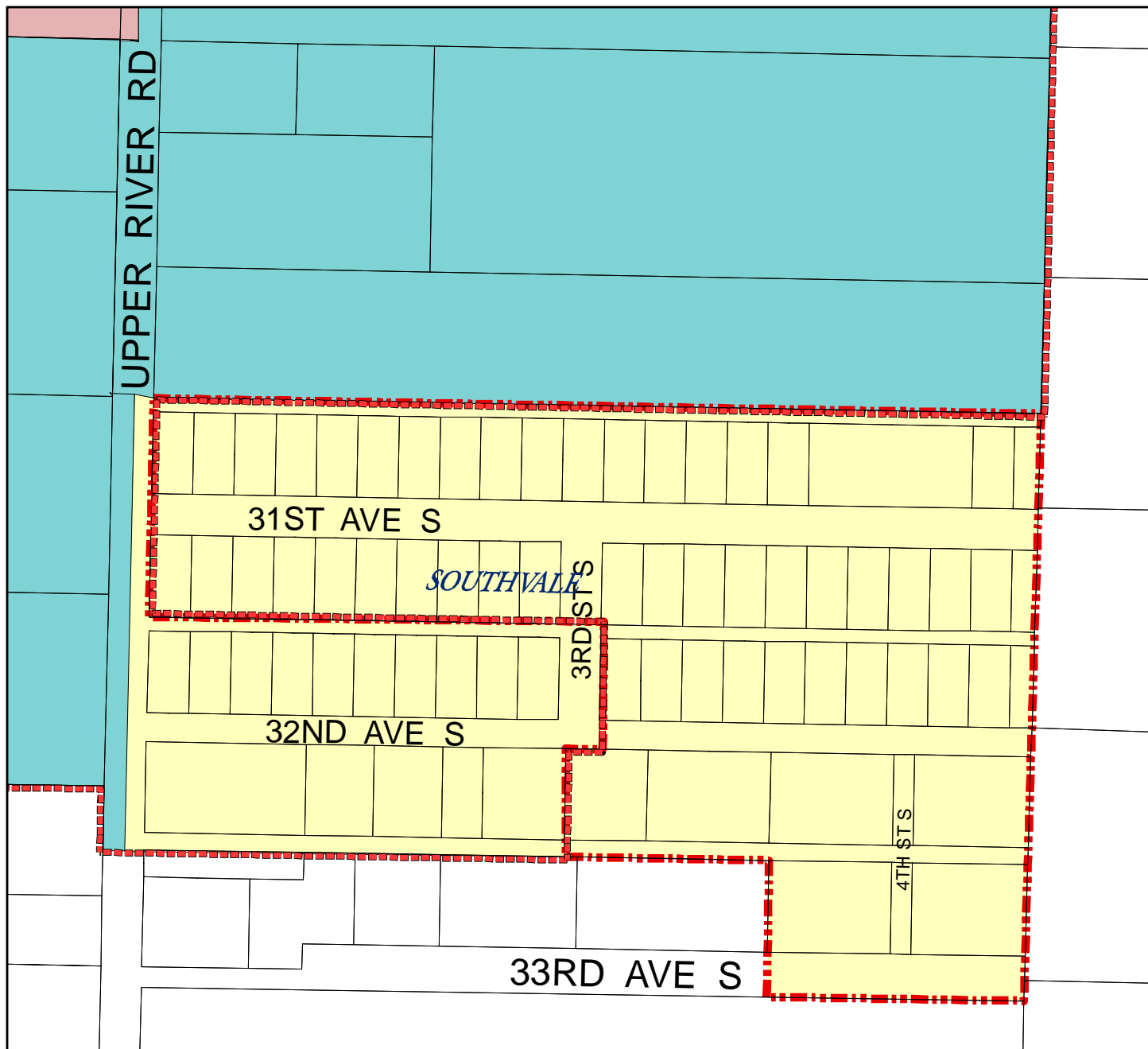

160 80 0 160 Feet



--- City Limits

ULRRWSD 4

ZONING

AI Airport Industrial

C-1 Neighborhood commercial

C-2 General commercial

C-3 Highway commercial

C-4 Central business core

C-5 Central business periphery

I-1 Light industrial

I-2 Heavy industrial

M-1 Mixed-use district

M-2 Mixed-use transitional

PLI Public lands institutional

POS Park Open Space

PUD Planned unit development

R-1 Single-family suburban

R-2 Single-family medium density

R-3 Single-family high density

R-5 Multi-family medium density

R-6 Multi-family high density

R-9 Mixed residential

R-10 Mobile home park

Unincorporated Enclave

Vicinity/Zoning Map

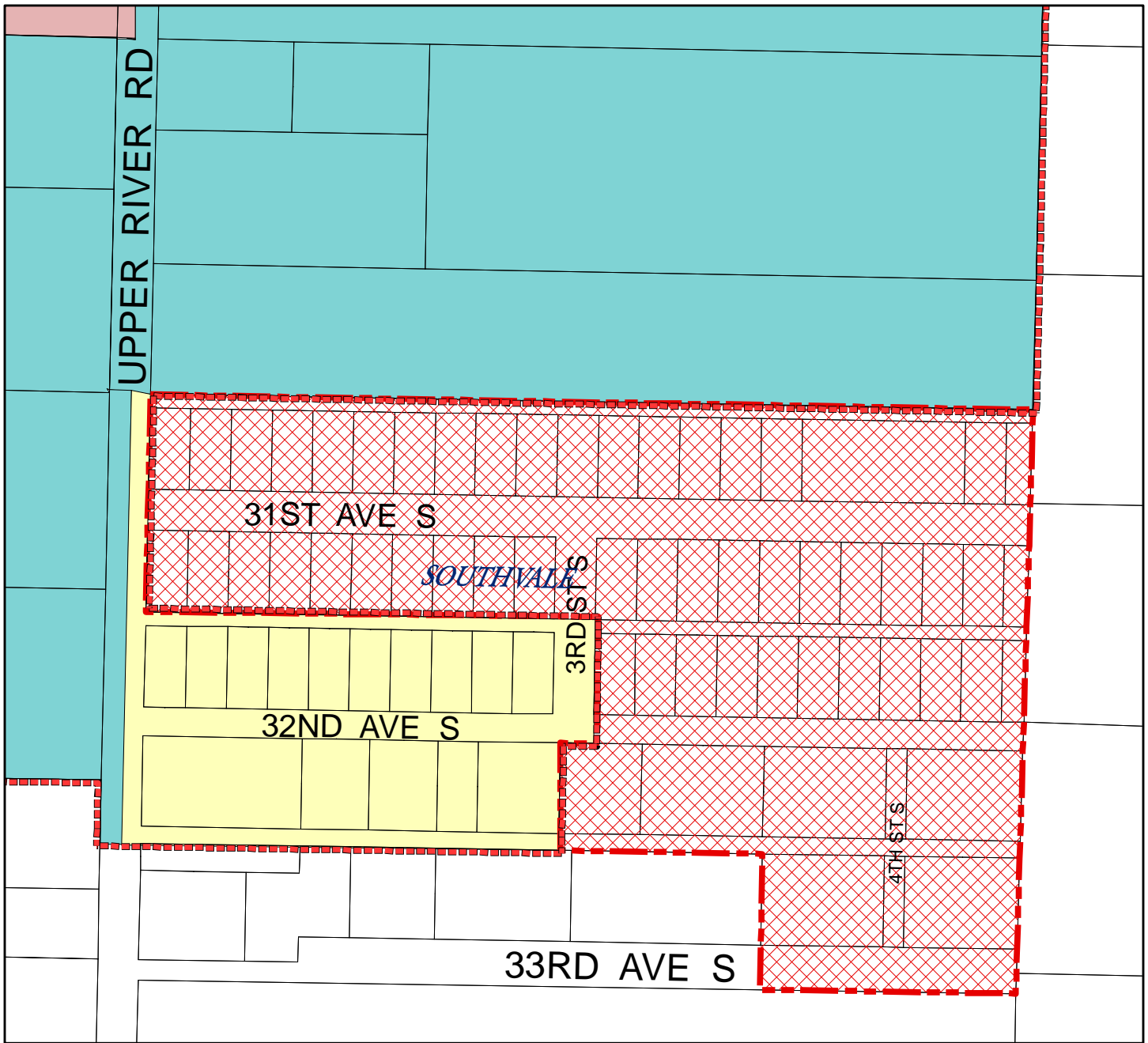

160 80 0 160 Feet



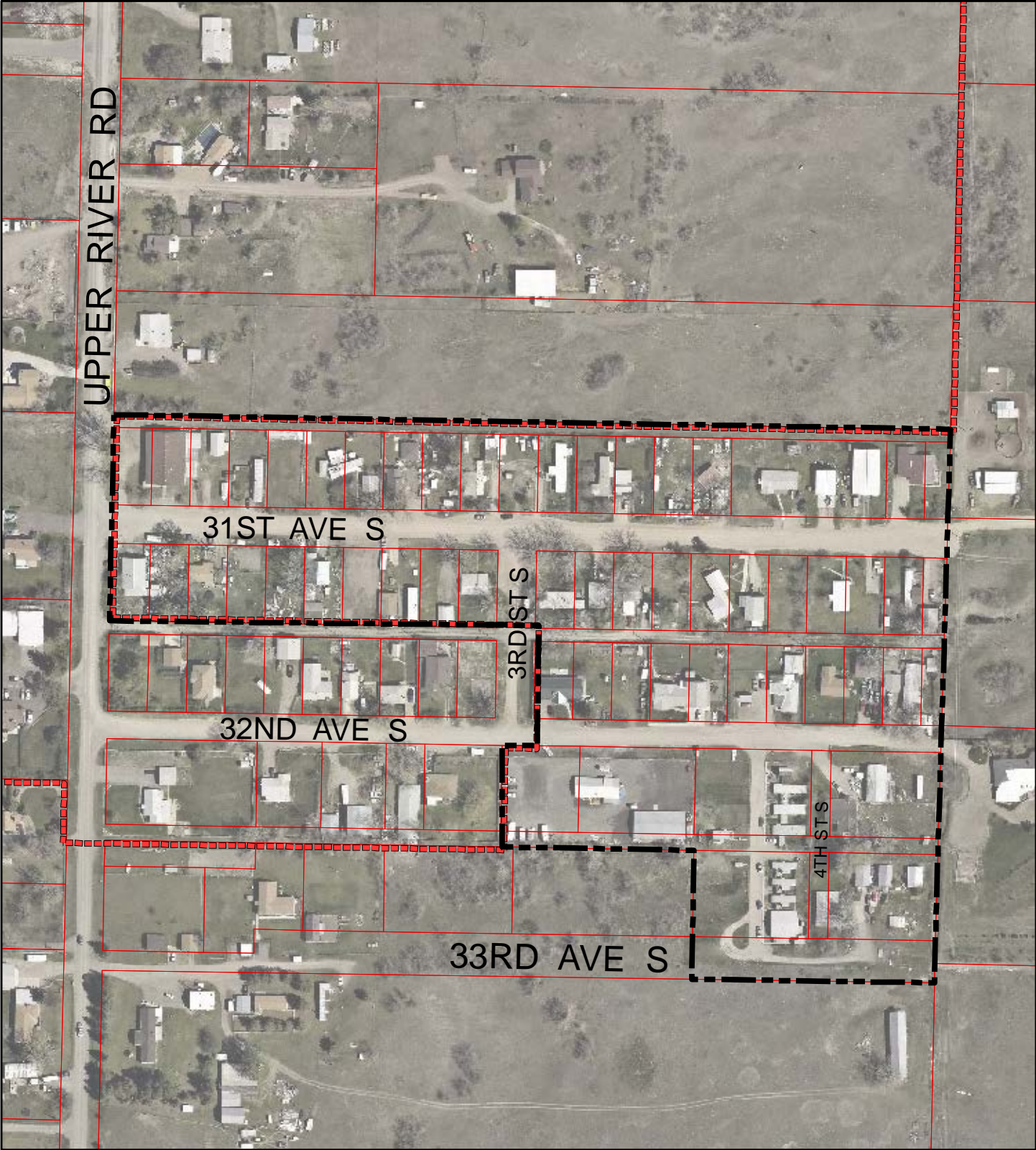

- | | | |
|---|--|--|
|  District 4 Boundary |  I-1 Light industrial |  R-2 Single-family medium density |
| ZONING |  I-2 Heavy industrial |  R-3 Single-family high density |
|  AI Airport Industrial |  M-1 Mixed-use district |  R-5 Multi-family medium density |
|  C-1 Neighborhood commercial |  M-2 Mixed-use transitional |  R-6 Multi-family high density |
|  C-2 General commercial |  PLI Public lands institutional |  R-9 Mixed residential |
|  C-3 Highway commercial |  POS Park Open Space |  R-10 Mobile home park |
|  C-4 Central business core |  PUD Planned unit development |  Unincorporated Enclave |
|  C-5 Central business periphery |  R-1 Single-family suburban | |

Aerial Photo



Aerial Photo: May, 2009

 District 4 Boundary
 Tracts of Land



Regular City Commission Meeting

Mayor Winters presiding

CALL TO ORDER: 7:00 PM

PLEDGE OF ALLEGIANCE – Vets4Vets

MOMENT OF SILENCE

ROLL CALL: City Commissioners present: Michael Winters, Bill Bronson, Fred Burow, Mary Jolley and Bob Jones. Also present were the City Manager, Deputy City Manager, City Attorney, Directors of Fiscal Services, Planning and Community Development, and Public Works, Deputy Director of Park and Recreation, Executive Director of the Housing Authority, Fire Chief, Police Chief and the City Clerk.

PROCLAMATIONS: Mayor Winters read proclamations for Constitution Week and Vets4Vets. Commissioner Jones read a proclamation for National Preparedness Month, and Commissioner Bronson read a proclamation for the 10th Anniversary of 9/11 National Day of Service and Remembrance.

**** Action Minutes of the Great Falls City Commission. Please refer to the audio recording of this meeting for additional detail. ****

NEIGHBORHOOD COUNCILS

1. SWEARING IN CEREMONY.

Mayor Winters swore in Rudolf Tankink as a representative of Neighborhood Council 4.

2. MISCELLANEOUS REPORTS AND ANNOUNCEMENTS.

Richard Calsetta, NC 3, discussed the agenda topics of the council's recent meeting. He encouraged support of the RSVP and senior services programs. Mr. Calsetta expressed disappointment that the old, unsafe playground equipment was removed from JC Park, Elks Riverside Park and Skyline Optimist Park without first informing neighborhood residents of the safety deficiencies found with the equipment and being given the opportunity to possibly make repairs to bring the equipment back up to safety standards acceptable by the inspector pending replacement.

Deputy Director of Park and Recreation Patty Rearden commented staff deemed that no repairs could be made to make the equipment safe. When it failed the safety inspection, staff met with the City's risk manager. City staff determined there was no alternative but to remove the equipment.

City Manager Greg Doyon commented that he advised the Commission to hold off until mid-year before taking any action on the additional assessed property revenue. One set of playground equipment has been replaced. Staff will be making a determination regarding the second set of equipment and will make an effort to get it restored as quickly as possible.

Mr. Calsetta encouraged City staff to attend meetings to keep the neighborhood councils informed.

Jack Stimac, NC 3, asked the Commission to keep in mind the large area that Riverview Park serves when considering the budget and replacing equipment.

BOARDS & COMMISSIONS

3. **AMENDED PLAT, LOT 1A, BLOCK 2, B.N. CAR SHOP ADDITION, GENERALLY LOCATED EAST OF 6TH STREET SW, NORTH AND WEST OF CRESCENT CIRCLE.**

Planning and Community Development Director Mike Haynes reported that this is a request to approve an amended plat for property that contains the former Buttrey Warehouse located on the east side of 6th Street SW at Crescent Circle. The property is zoned I-1 (Light Industrial).

The applicant/owner is proposing to subdivide the ±12.86-acre property into five lots. Four new lots – Lots 2 through 5 – totaling 1.45 acres would be created along the south boundary of the property adjacent to Ryan's Station with access from Crescent Circle. Lot 1 would be the remaining 11.41 acres that encompasses the existing warehouse building and the surface parking areas. A shared parking agreement will be required to ensure adequate off-street parking will be available for employees, customers and visitors to the existing warehouse and future new development.

The Planning Advisory Board recommended that the City Commission approve the amended plat at a public hearing held on August 9, 2011.

Commissioner Bronson moved, seconded by Commissioner Jones, that the City Commission approve the Amended Plat of Lot 1A, Block 2, B.N. Car Shop Addition, a subdivision in the W½ Section 11, T20N, R3E, P.M.M., Cascade County, Montana, and accept the Findings of Fact.

Mayor Winters asked if there was any discussion amongst the Commissioners or inquiries from the public. Hearing none, Mayor Winters called for the vote.

Motion carried 5-0.

4. **MISCELLANEOUS REPORTS AND ANNOUNCEMENTS.**

Cyndi Baker, 500 Montana Avenue NW, member of the Police Department Citizens' Academy, announced the major donors of funds raised for two K-9 police dogs. A naming contest is being held by school children, and she requested submissions by members of the community.

PUBLIC HEARINGS

5. **AMERICAN LEGION BASEBALL CLUB LEASE.**

Deputy Park and Recreation Director Patty Rearden requested that the City Commission conduct a public hearing to consider approval of the American Legion Baseball Club Lease Agreement.

The proposed lease would be for ten (10) years with a five (5) year extension at the City's discretion. The rental rate is five hundred dollars (\$500) per year. The American Legion Baseball Club is responsible for improvements, repairs and maintenance. The City is responsible for water

costs for irrigation, up to a maximum of one thousand dollars (\$1,000) per year. This has been accepted policy with other baseball programs and is recommended in the Park and Recreation Master Plan. The Park and Recreation Master Plan also recommends that the City's responsibility should be to provide land for youth sport organizations.

Bids were not solicited for this lease since City ordinance provides an exception "where the use is to continue for a public purpose and the same is subject to a revision to the City should use ever be changed to any other purpose." In addition, the City acquired this property for the expressed use by American Legion baseball.

Staff recommends approval of the lease, and the Park and Recreation Advisory Board recommended approval at its August 8, 2011, meeting.

Mayor Winters declared the public hearing open.

No one spoke in opposition to the American Legion Baseball Club lease.

Speaking in support of the American Legion Baseball Club lease were:

Mike Witsoe, 510 11th Street South, reviewed the terms of the lease as reported by Ms. Rearden. Mr. Witsoe commented this lease is a positive for the Park and Recreation Department and the City's use of the land.

Ron Gessaman, 1006 36th Avenue NE, noted he was not speaking in favor of or in opposition to the American Legion Baseball Club lease. In response to his request for clarification, Ms. Rearden commented that this was a renewal of the lease of the same use.

There being no one else to address the Commission, Mayor Winters declared the public hearing closed.

Commissioner Jones moved, seconded by Commissioner Bronson, that the City Commission approve the American Legion Baseball Club Lease Agreement.

Mayor Winters asked if there was any discussion amongst the Commissioners.

Commission Burow commented that the lease payment should cover the cost of the water. City Manager Greg Doyon responded that the maintenance, facility improvements and lawn care by the Club probably exceeds the amount the City pays for water.

Ms. Rearden added that the Club has made significant improvements and performs all maintenance. It would cost significantly more than the \$500 difference for the City to maintain.

Mayor Winters requested that Ms. Rearden provide a cost comparison.

Motion carried 5-0.

6. **TRADE OR SALE OF CITY-OWNED PROPERTY: LOT 3, BLOCK 13, BROADWATER BAY BUSINESS PARK (YAW-KINNEY PROPERTY).**

Planning and Community Development Director Mike Haynes reported that this is the public hearing to take action on the trade or sale of the ±1.06 acre City-owned Yaw-Kinney property located behind the Civic Center at 11 River Drive South. City Code specifies procedures for the disposition of City property. The City acquired the property in 2002 for \$250,000. In the appraisal report dated May 31, 2011, McKay Rowen Associates valued the property at \$275,000. In response to an Invitation to Bid, two bids were received, both from Dahlquist Realtors on behalf of Pacific Steel. The primary offer was to trade ±2 acres of land immediately south of the Police Station, valued at \$300,000, for the Yaw-Kinney property. The second “back-up” offer was to purchase the Yaw-Kinney property for the appraised value of \$275,000. City Staff and Pacific Steel prefer the trade option which would leave the City with two acres of developable land on the Civic Center campus and allow Pacific Steel to aggregate the Yaw-Kinney property and the adjacent Big Sky Transfer property for development of new corporate headquarters.

Mayor Winters declared the public hearing open.

No one spoke in opposition to the trade or sale of City-owned Yaw-Kinney property.

Speaking in support of the trade or sale of City-owned Yaw-Kinney property were:

Stuart Lewin, 615 3rd Avenue North, inquired how the \$300,000 for the two acres was determined. Mr. Haynes responded that Pacific Steel will acquire the property from the current property owners for \$300,000 and then trade that property to the City for the Yaw-Kinney property.

Mr. Lewin inquired if Mr. Haynes had seen a contract. Mr. Doyon responded that the City did not perform an appraisal of the property that is proposed for trade. Representatives of Pacific Steel will explain how the value was determined.

Steve L’Heureux, L’Heureux Page Werner, 1826 3rd Avenue North, clarified that Pacific Steel does have a contract to purchase that property that is executable upon Commission approval of the trade of the Yaw-Kinney property.

Mike Witsoe, 510 11th Street South, questioned the timing, and then referred to this proposal as a “boondoggle.”

Mr. Doyon explained the process of the trade or sale of City property. This is a good opportunity for the City. The City is not losing property. The City is gaining land that will be made available should the community decide it needs an expanded police or justice facility. Nothing has been advanced other than a conceptual idea and a recognition that there is a need for additional space.

Mayor Winters also noted that the Yaw-Kinney building was not suitable for a museum.

Stuart Lewin, 615 3rd Avenue North, commented that staff should perform its due diligence and look at the contract.

Mr. Haynes commented that the bids specified that the owner of the property had an offer and, if the trade was approved, would close on the sale of that property.

Scott Blumfield, Dahlquist Commercial Investment, 500 Country Club Blvd., commented that he wrote the contract. Two acres will be traded for just over one acre and Pacific Steel will be paying \$300,000 for property appraised at \$275,000. Mr. Blumfield further pointed out that the County's tax value on the property is \$460,000.

Steve L'Heureux, L'Heureux Page Werner, commented that Pacific Steel's move to downtown is contingent on the Commission's decision because they need more space than they currently have. Mr. L'Heureux provided a PowerPoint presentation depicting the site and rendition of the improved property. Construction is expected to start in the spring with an approximate 10 month completion time. Mr. L'Heureux introduced Pat Kons and Tim Culliton of Pacific Steel & Recycling.

Pat Kons, Pacific Steel & Recycling Vice-President of Scrap Operations, commented that approval of the trade is great for the company, culture and heritage to be here in Great Falls. Pacific Steel has 42 branches in nine states. They have many options for a corporate office. Since Pacific Hide and Fur Depot was founded in Great Falls in the late 1800's, they think it is appropriate to renovate and keep their roots in Great Falls.

Cyndi Baker, 500 Montana Avenue NW, commented that Pacific Steel & Recycling was a sponsor of the K-9 fund raising project. She noted the large amount of plaques she observed on Pacific Steel's corporate office wall from various organizations. She concluded, "when Pacific prospers, Great Falls prospers."

There being no one else to address the Commission, Mayor Winters declared the public hearing closed.

Commissioner Bronson moved, seconded by Commissioner Burow, that the City Commission approve the trade of the City-owned Yaw-Kinney Property: Lot 3, Broadwater Bay Business Park, for the ±2 acre undeveloped property addressed as 210 1st Street South (Parcel ID 526300), and authorize the City Manager to execute the necessary documents.

Mayor Winters asked if there was any discussion amongst the Commissioners.

Commissioner Burow commented that he appreciates Mr. Lewin's comments. He believes this to be a win-win situation, and supports this project.

Motion carried 5-0.

7. RESOLUTION 9936 TO LEVY AND ASSESS PROPERTIES FOR UNPAID UTILITY SERVICES.

Fiscal Services Director Melissa Kinzler reported that properties in the City of Great Falls which had utility services provided to them prior to June 30, 2011, but remain unpaid, are subject to the City's right to assess the property for the amount owed. The Fiscal Services Department reviews the accounts annually and notifies property owners of the delinquent charges and right to assess the property. The legal owners of the properties were notified in a letter dated June 27, 2011, that

unless these charges were paid within 30 days, they would be levied as a tax against the lot or parcel. A final letter stating the date and time of the public hearing was sent to the owners of the property with charges remaining unpaid on August 19, 2011. This assessment will appear on the property tax bill received from the Cascade County Treasurer. Any payments received prior to the charges being forwarded to the Cascade County Treasurer will be removed from the assessment listing.

Mayor Winters declared the public hearing open.

Speaking in opposition to Resolution 9936 was:

Mike Witsoe, 510 11th Street South, inquired what it costs to put a lien on someone's property.

Ms. Kinzler responded that it is a per page cost to record the document. The cost of filing the lien is not passed on to the customer.

No one spoke in support of Resolution 9936.

Mayor Winters declared the public hearing closed.

Commissioner Burow moved, seconded by Commissioner Bronson, that the City Commission adopt Resolution 9936.

Mayor Winters asked if there was any discussion amongst the Commissioners.

Commissioner Burow inquired why the recording cost wasn't included in the amount owed.

Ms. Kinzler responded that hasn't been past practice, but could be looked at changing in the future.

City Clerk Lisa Kunz added that the per page fee is for recording the resolution and attachment; it is not a per property fee.

Commissioner Jolley noted that the terms assessment and lien are used. She inquired when this Resolution is recorded with the County if people see a bill on their taxes or a lien on their home.

Ms. Kinzler responded that it is a lien on the parcel of property.

Motion carried 5-0.

8. **CRESCENT DRIVE LOTS CONSISTING OF ± 13.32 ACRES LOCATED NORTH OF CRESCENT DRIVE AND WEST OF 6TH STREET SOUTHWEST.**
- A. **ORDINANCE 3080 REZONE FOUR LOTS FROM C-2 GENERAL COMMERCIAL TO I-1 LIGHT INDUSTRIAL.**
- B. **MINOR PLAT OF THAYER DEVELOPMENT AND ACCOMPANYING FINDINGS OF FACT.**

Planning and Community Development Director Mike Haynes reported that this public hearing is to consider Ordinance 3080 that would rezone four lots containing ±13.32 acres from C-2 (General Commercial) to I-1 (Light Industrial) and an amended plat to subdivide the easternmost lot - Mark 22LA - into two lots. The subject properties are located on the north side of Crescent Drive west of 6th Street SW and comprise a cell tower, storage units, a landscape business, a grain elevator and a vacant building that was formerly used for daycare.

The owner of Mark 22LA will also be required to obtain a right-of-way encroachment permit from Public Works for the vacant building that was constructed encroaching into the Crescent Drive right-of-way.

Staff is recommending approval of the rezoning based on two major factors: The industrial nature of existing uses on the subject properties, and the location of subject properties between the railroad and golf course to the north and the West Great Falls Levee to the south, that alleviate typical concerns regarding compatibility of industrial with other uses (especially residential).

At a public hearing held on July 12, 2011, the Planning Advisory Board/Zoning Commission recommended that the City Commission approve the rezoning and the minor subdivision.

Mayor Winters declared the public hearing open.

No one spoke in opposition to Ordinance 3080 and minor plat.

Speaking in support of Ordinance 3080 and minor plat was:

Gene Thayer, property owner and applicant, commented as a board member of the Great Falls Development Authority that this property has rail that the board hopes will attract businesses.

Ron Gessaman, 1006 36th Avenue NE, thanked Mr. Thayer for “showing up” to discuss his project.

Jeremiah Johnson, 1900 Whispering Ridge Drive, commented that the Great Falls Development Authority supports this re-zoning.

There being no one else to address the Commission, Mayor Winters declared the public hearing closed.

Commissioner Jones moved, seconded by Commissioner Bronson, that the City Commission adopt Ordinance 3080.

Mayor Winters asked if there was any discussion amongst the Commissioners. Hearing none, Mayor Winters called for the vote.

Motion carried 5-0.

Commissioner Bronson moved, seconded by Commissioners Jolley and Jones, that the City Commission approve the Minor Plat of Thayer Development and the accompanying Findings of Fact subject to fulfillment of conditions stipulated by the Planning Advisory Board.

Mayor Winters asked if there was any discussion amongst the Commissioners. Hearing none, Mayor Winters called for the vote.

Motion carried 5-0.

9. **1ST AVENUE NORTHWEST AND A PORTION OF RAILROAD STREET AND ASSOCIATED AMENDED PLAT.**
 - A. **RESOLUTION 9940 TO VACATE A PORTION OF 1ST AVENUE NW AND A PORTION OF RAILROAD STREET.**
 - B. **AMENDED PLAT OF LOTS 3 AND 4, BLOCK 598, AND A PORTION OF 1ST AVENUE NW, OF THE 5TH ADDITION TO GREAT FALLS, AND PARCEL NO. 2.**

Planning and Community Development Director Mike Haynes reported that this public hearing is to consider Resolution 9940 for the abandonment of public right-of-way comprising ± 0.4 acres and the related amended plat. The subject property is a portion of the 1st Avenue NW and Railroad Street rights-of-way located just north of the intersection of Central Avenue West and 3rd Street on the Talcott Properties, LLC site. The subject right-of-way is not used or needed for the street network and abandonment will allow the abutting property owner to incorporate the subject property into their site which is being developed in phases and comprises the Staybridge Suites Hotel and the recently completed commercial building that is home to Faster Basset Coffee and Crepes.

There are other property owners in the vicinity of the subject property who are not part of the application and will not be adversely affected by the abandonment.

The amended plat includes utility easements in favor of the City for underground water, sewer and stormdrain infrastructure.

On July 26, 2011, the Planning Advisory Board recommended the City Commission approve the abandonment.

Mayor Winters declared the public hearing open.

No one spoke in opposition to or in support of Resolution 9940 and the amended plat.

Mayor Winters declared the public hearing closed.

Commissioner Jolley moved, seconded by Commissioner Jones, that the City Commission adopt Resolution 9940.

Mayor Winters asked if there was any discussion amongst the Commissioners. Hearing none, Mayor Winters called for the vote.

Motion carried 5-0.

Commissioner Jolley moved, seconded by Commissioners Burow and Jones, that the City Commission approve the Amended Plat of Lots 3 and 4, Block 598, and a portion of 1st

Avenue NW, of the 5th Addition to Great Falls, and Parcel No. 2, all located in Government Lot 7 of Section 2, the NW¹/₄, and Government Lot 2 of Section 11, T20N, R3E, M.P.M., Great Falls, Cascade County, Montana.

Mayor Winters asked if there was any discussion amongst the Commissioners. Hearing none, Mayor Winters called for the vote.

Motion carried 5-0.

** Item 14 is a public hearing that was inadvertently left under Ordinances/Resolutions on the Agenda.

14. RESOLUTION 9942, NEW OR EXPANDING INDUSTRY TAX BENEFIT, 1408 52ND STREET NORTH.

Planning and Community Development Director Mike Haynes reported that this public hearing is to consider Resolution 9942 to approve Steel Etc.'s application for a New or Expanding Industry Tax Benefit for approximately \$79,000 in miscellaneous taxable personal property investments. The Department of Revenue has confirmed that equipment purchased for installation and use on that portion of the Steel Etc. property in the City, qualifies for tax abatement with tax year 2011 considered the year of acquisition.

On August 4, 2009, the City Commission approved annexation of the ±4.7 acre developed portion of the Steel Etc. property into the City. On August 17, 2010, City Commission approved the New or Expanding Industry Tax Benefit for approximately \$3.2 million worth of improvements including construction of a new business office building, steel sales building, scrap and recycling building and installation of utilities.

In June, 2011, the Cascade County Commissioners approved property tax abatement on just over \$200,000 of heavy equipment investments on the ±11.2 acre portion of the Steel Etc. property that remains in Cascade County.

The requested New or Expanding Industry Tax Benefit would provide Steel Etc. with property tax abatement on a portion of the additional city property taxes generated by the new investment. The discount on new property taxes would be 50% in years 1-5, 40% in year 6, 30% in year 7, 20% in year 8, and 10% in year 9. In year 10 and in subsequent years 100% of the additional property taxes resulting from the new development would be payable.

The City Commission established a policy to approve tax abatements for qualifying new and expanding industries in Resolution 8967, adopted in July, 1998.

Mayor Winters declared the public hearing open.

Speaking in opposition to Resolution 9942 was:

Ron Gessaman, 1006 36th Avenue NE, expressed his opposition to tax breaks to businesses by any local government.

Speaking in support of Resolution 9942 was:

Karen Grove, 1816 1st Avenue North, commented that Steel Etc. is a local business that donates back to this community. She objects to the term of “moocher” used by Mr. Gessaman.

Cyndi Baker, 500 Montana Avenue NW, commented that this will benefit the business and shows that the City values their investment in the community. Steel Etc. is a good partner in this community.

There being no one else to address the Commission, Mayor Winters declared the public hearing closed.

Commissioner Bronson moved, seconded by Commissioner Jones, that the City Commission adopt Resolution 9942.

Mayor Winters asked if there was any discussion amongst the Commissioners.

Commissioner Bronson commented that he hopes there will be many more businesses like Steel Etc. in this community in the future.

Commissioner Jolley commented that her understanding is this is a State initiated tax abatement.

Mr. Haynes responded that the City Commission passed a resolution in 1988 showing its commitment to approve these benefits. He believes it requires the approval of local governments.

Motion carried 5-0.

OLD BUSINESS

NEW BUSINESS

10. CONTRACT, CITY WEBSITE DESIGN AND CONTENT MANAGEMENT SYSTEM.

Fiscal Services Director Melissa Kinzler reported that City staff discussed the increased demand for a SQL Database Specialist at the June 7, 2011, Work Session. City Staff recommended moving the current Website Specialist into the SQL Database role, outsourcing website design, and implementing a Content Management System (CMS) which would give departments the ability to control their own web pages. Commissioners advised City Staff to move forward with the RFP process.

Nine vendors submitted proposals in response to the Request for Proposals. A group of City staff representing various departments was selected to view the vendor presentations/demos and give input/feedback. aHa Consulting was determined to not only be highly capable but also cost effective.

aHa Consulting will meet with City Staff and implement the proposed redesign and CMS over a three month period. Phase I will consist of assessing the current website and the City's needs/requirements. In Phase II, aHa Consulting will be building and designing the City website. Phase III will consist of training departmental Content Managers (those who will be updating the website) and migrating data from the old site to the new site. In the last phase, aHa will conduct testing and then the City will go live on the new website.

Commissioner Jolley moved, seconded by Commissioner Jones, that the City Commission approve the contract between the City of Great Falls and aHa Consulting, Inc. for Web Design and Content Management System for a fee not to exceed \$40,000, and authorize the City Manager to execute the Agreement.

Mayor Winters asked if there was any discussion amongst the Commissioners.

Commissioner Burow inquired if the bid was \$28,000, why was the Commission being asked to approve \$40,000.

Ms. Kinzler explained that the bid amount included 250 pages of website design. After Phase I, staff will have a better idea of how many pages will need to be converted.

Commissioner Burow commented that he would not like to see a future change order.

I.T. Manager Jon Legan added that a number of pages will be consolidated and City staff will be able to convert pages after aHa creates the template.

Mayor Winters asked if there were any inquiries from the public.

Ron Gessaman, 1006 36th Avenue NE, inquired if training costs were included.

Ms. Kinzler responded that training is included in Phase 3 and the cost is included in the \$40,000.

Commissioner Jolley provided Mr. Gessaman with a copy of the aHa proposal.

Mr. Gessaman commented that there will be ongoing costs to maintain the website.

Commissioner Jones explained that the City's full-time webmaster currently updates the site on behalf of all the departments. This company will design a new website and make it easier for upgrades. Department staff will now be responsible for keeping the site up to date.

In response to Mr. Gessaman, Mr. Doyon responded that after City staff is trained to update their own content, the webmaster will be transitioned into another role.

Mike Witsoe, 510 11th Street South, inquired where the office of aHa Consulting was located and was informed Oregon.

Motion carried 5-0.

ORDINANCES/RESOLUTIONS

11. RESOLUTION 9928 TO LEVY AND ASSESS PROPERTIES WITHIN THE TOURISM BUSINESS IMPROVEMENT DISTRICT.

Fiscal Services Director Melissa Kinzler reported that this is the final step to assess properties within the Tourism Business Improvement District (TBID). The TBID was created for the purpose of promoting tourism, conventions, trade shows and travel to the City of Great Falls.

The proposed budget and work plan were presented to the City Commission on July 19, 2011. The public hearing was held on August 2, 2011. Staff recommends that the City Commission adopt Resolution 9926 to levy and assess properties within the TBID.

Commissioner Jolley moved, seconded by Commissioners Bronson and Burow, that the City Commission adopt Resolution 9928.

Mayor Winters asked if there was any discussion amongst the Commissioners.

Commissioner Jolley inquired why some properties were exempt.

Ms. Kinzler responded that there are exemptions under state statute that has to do with the length/type of stay.

Mayor Winters asked if there were any inquiries from the public. Hearing none, Mayor Winters called for the vote.

Motion carried 5-0.

12. **RESOLUTION 9929 TO LEVY AND ASSESS PROPERTIES WITHIN THE BUSINESS IMPROVEMENT DISTRICT.**

Fiscal Services Director Melissa Kinzler reported that this is the last step to assess properties within the Business Improvement District (BID). The BID was created to improve and revitalize the downtown area. The proposed budget and work plan were presented to the City Commission on July 19, 2011. The public hearing was held on August 2, 2011. Staff recommends that the City Commission adopt Resolution 9929 to levy and assess properties within the BID.

Commissioner Bronson moved, seconded by Commissioner Jones, that the City Commission adopt Resolution 9929.

Mayor Winters asked if there was any discussion amongst the Commissioners or inquiries from the public. Hearing none, Mayor Winters called for the vote.

Motion carried 5-0.

13. **RESOLUTION 9937 TO LEVY AND ASSESS THE COST OF REMOVAL AND DISPOSAL OF NUISANCE WEEDS IN THE CITY OF GREAT FALLS FROM JUNE 1, 2010, TO MAY 30, 2011.**

Fiscal Services Director Melissa Kinzler reported from May through October of each year nuisance weed violations are reported to the Public Works Department. The Nuisance Weed Program involves investigation and notification of verified weed and grass violations. The investigation process involves an on-site inspection followed by the determination of the legal ownership of the properties. Once ownership of the properties has been established, notification letters of nuisance weed violations are prepared and mailed. Owners are given seven business days from the date of the notification letter to comply with the weed ordinance. After the allotted time has expired, properties are once again inspected. There are 55 remaining property owners who will be assessed

for a total amount of \$17,180.00, for non-payment after monthly billings.

Commissioner Burow moved, seconded by Commissioners Jolley and Jones, that the City Commission adopt Resolution 9937.

Mayor Winters asked if there was any discussion amongst the Commissioners or inquiries from the public. Hearing none, Mayor Winters called for the vote.

Motion carried 5-0.

** 14. ** Item 14 is a public hearing that was inadvertently left under Ordinances/Resolutions on the Agenda. (See Item 14 above under the title of Public Hearings.)

CONSENT AGENDA

15. Minutes, August 16, 2011, Commission meeting.
16. Total expenditures of \$3,424,297 for the period of August 5-31, 2011, to include claims over \$5,000, in the amount of \$2,998,596.
17. Contracts list.
18. Lien Release list.
19. Approve Change Order No. 1 in the amount of \$4,569 to Central Plumbing and Heating for the Boys and Girls Club of Cascade County HVAC Renovation. **OF 1620**
20. Approve Fiscal Year 2012 Traffic Signal and Sign Maintenance Agreements with the Montana Department of Transportation.
21. Award contract to Phillips Construction LLC in the amount of \$217,990 for the Northwest Storm Drain Improvements Phase 1 – Intersection 34th and 35th Avenue NE & 11th Street NE. **OF 1617.1**
22. Approve Change Order No. 1 in the amount of \$70,782.36 and Final Payment in the amount of \$74,001.77 for the 2011 Street Repairs to Great Falls Sand & Gravel Inc. and \$747.49 to the State Miscellaneous Tax Division and authorize the City Manager to make the payments. **OF 1611.1**
23. Approve Change Order No. 2 in the amount of \$19,849 to Central Plumbing and Heating, Inc. for the Montana Eggs Utility Extensions. **OF 1610**
24. Approve Final Payment in the amount of \$1,493.81 to Shumaker Trucking and Excavating Contractors, Inc. and the State Miscellaneous Tax Division for the 11th Alley North Sewer Relocation. **OF 1566.7**
25. Approve Final Payment in the amount of \$4,158.20 to Great Falls Sand & Gravel, Inc. and the State Miscellaneous Tax Division for the Broadwater Bay Park – Parking Lot Expansion. **OF 1606**
26. Approve Final Payment in the amount of \$63,370.10 to United Materials of Great Falls, Inc. and the State Miscellaneous Tax Division for the Phase II 1st Avenue and 2nd Avenue North Water Main

Replacements. **OF 1599**

27. Approve Final Payment in the amount of \$2,718.35 to Phillips Construction LLC and the State Miscellaneous Tax Division for the 11th Street North Utilities Extension/Replacement. **OF 1556**

Commissioner Burow moved, seconded by Commissioner Bronson, that the City Commission approve the Consent Agenda, with the exception of Item 19 for additional discussion.

With regard to Item 20, Commissioner Jolley thanked Public Works' staff for the summary of costs, and also inquired what the cameras were filming.

Public Works Director Jim Rearden responded that video cameras are used for motion detection to control the light operation.

Commissioner Burow requested clarification on Item 19.

Mr. Doyon referred to the agenda report that identified the add-on controller would improve the efficiency of the building.

Commissioner Jolley commented that the project had to be re-bid because the original bids came in too high. There wasn't enough money to do what they wanted. Installing the controller will make the building more efficient.

Ms. Rearden added that L'Heureux Page Werner donated their services to re-do the bid package. Bids came in low, so they had additional money to pay for the controllers.

Mr. Doyon noted that an answer would be provided when Marty Basta returns. He further clarified that the Commission was ratifying bills that may have already been paid. If the Commission doesn't want staff to pay this change order, then the Commission should note that in the motion to bring this item back at the next meeting for a vote.

Mayor Winters asked if there were any inquiries from the public.

Ron Gessaman, 1006 36th Avenue NE, inquired about the cost for the play structure listed on Item 16.

Ms. Rearden responded that approximately \$40,000 would be a sufficient amount for playground equipment at JC and Skyline Parks. Designs proposals were submitted according to a set price.

Mr. Gessaman noted that he has only seen two people playing tennis at Elks Riverside Park on one occasion this week.

Mr. Gessaman commented that the June payments to Southern amounted to \$1,090,512.28, at a cost of approximately \$74 per megawatt.

In response to Mr. Gessaman, Ms. Kinzler commented that the payment is an estimated amount for July.

Mr. Gessaman was responded to affirmatively in response to his comments that the July amount

was lower because some of the customers departed, and that the July deposit that was listed was the third installment.

Mike Witsoe, 510 11th Street South, inquired the nature of the upgrade with regard to Item 21. Public Works Director Jim Rearden explained that this item is part of the Northwest Storm Drain Study. Improvements include additional inlets and grading to direct storm drain properly away from properties.

Mr. Witsoe inquired if the storm drain pipes were adequate. Mr. Rearden responded that pipe size deficiencies are being corrected.

With regard to Item 23, Mr. Witsoe inquired the nature of the Change Order. Mr. Rearden explained that additional asphalt work will be split between Montana Eggs and the City.

Mr. Witsoe inquired about Item 25 and was informed the parking lot expansion to the north of McKenzie River would accommodate 13 trucks and boat trailers.

There being no further discussion, Mayor Winters called for the vote with regard to accepting the Consent Agenda as presented.

Motion carried 4-1 (Commissioner Burow dissenting).

PETITIONS AND COMMUNICATIONS

28. MISCELLANEOUS REPORTS AND ANNOUNCEMENTS.

Mayor Winters opened the meeting to Petitions and Communications.

- A. Jack Stimac**, 154 Riverview C, commented that Great Falls is the only place he has been denied access to park his motorcycle in the parking garages unless he buys a monthly pass. He inquired what could be done about that. Mr. Haynes responded that he would research the issue and get back to Mr. Stimac and the Commission.
- B. John Hubbard**, 615 7th Avenue South, commented that the *Tribune* misquoted him in a recent article about the amount of losses with regard to the coal plant and ECP. His solution is to hold prior elected officials and City staff accountable for misappropriation of tax dollars.
- C. Ron Gessaman**, 1006 36th Avenue NE, discussed ECP's losses. He commented that during this Commission's term, ECP has had a loss of roughly \$2.5 million that need not have occurred if the decision to end ECP's operation had occurred in January, 2010. Mr. Gessaman referred to Jon Doak's August 30, 2011, letter, and commented that he has never seen any reference to Southern Policy D-11 until now. He suggested that the City take a court reporter and videographer to Southern meetings in Billings for a record of what happens there.
- D. Mike Witsoe**, 510 11th Street South, discussed this weekend's Autism walk and other local events.

CITY MANAGER

29. MISCELLANEOUS REPORTS AND ANNOUNCEMENTS.

City Manager Greg Doyon reported that he and the Deputy City Manager will be attending a conference in Milwaukee next week. He plans on asking Mr. Santoro to be acting city manager in their absence. Mr. Doyon recommended that the Commission allow him to appoint Commissioner Jones as the Southern Board trustee. He would still attend to take notes. Mayor Winters commented that Commissioners have discussed that and he concurs with that recommendation.

Mr. Doyon also noted that City 7 is having technical difficulties and this meeting probably isn't being aired live.

Deputy City Manager Jennifer Reichelt thanked Colonel Cotton for his service to our community.

CITY COMMISSION

30. MISCELLANEOUS REPORTS AND ANNOUNCEMENTS.

Commissioner Burow thanked the Great Falls Police Officers that responded to an incident at his residence.

Mayor Winters thanked City employees for the good job they all do.

ADJOURNMENT

There being no further business to come before the regular Commission meeting, **Commissioner Bronson moved, seconded by Commissioner Jones, that the regular meeting of September 6, 2011, be adjourned at 9:42p.m.**

Motion carried 5-0.

Mayor Winters

City Clerk

Minutes Approved: September 20, 2011



ITEM: \$5,000 Report
 Invoices and Claims in Excess of \$5,000

PRESENTED BY: Fiscal Services Director

ACTION REQUESTED: Approval with Consent Agenda

LISTING OF ALL ACCOUNTS PAYABLE CHECKS ISSUED AVAILABLE ONLINE AT
www.greatfallsmt.net/people_offices/fiscal/checkregister.php

**TOTAL CHECKS ISSUED AND WIRE TRANSFERS MADE ARE NOTED BELOW WITH AN
 ITEMIZED LISTING OF ALL TRANSACTIONS GREATER THAN \$5000:**

ACCOUNTS PAYABLE CHECK RUNS FROM SEPTEMBER 01 - 14, 2011	2,069,048.64
MUNICIPAL COURT ACCOUNT CHECK RUN FOR AUGUST 26 - 31, 2011	71,144.00
MUNICIPAL COURT ACCOUNT CHECK RUN FOR SEPTEMBER 1 - 9, 2011	1,201.00
WIRE TRANSFERS FROM SEPTEMBER 1 - 7, 2011	32,087.68
WIRE TRANSFERS FROM SEPTEMBER 8 - 14, 2011	124,660.46
TOTAL: \$	2,298,141.78

GENERAL FUND

LEGAL

MOULTON BELLINGHAM PC	LEGAL FEES THROUGH MAY, 2011	19,416.05
	ECP v SME	
MOULTON BELLINGHAM PC	LEGAL FEES JUNE 2011 ECP V SME	8,646.08

POLICE

BVAC INC	AMMUNITION	14,285.00
----------	------------	-----------

SPECIAL REVENUE FUND

TAX INCREMENT

GREAT FALLS DEVELOPMENT AUTHORITY	DRAWDOWN LOAN FOR M&L RENTALS FOR DOWNTOWN REVOLVING LOAN FUND	70,000.00
--------------------------------------	---	-----------

CTEP PROJECT

LIBERTY ELECTRIC INC	PMT #1 GIBSON PARK LIGHTING INSTALLATION	18,059.82
----------------------	---	-----------

LIGHTING DISTRICT

CONSOLIDATED ELECTRICAL DIST	STERN 4 - G14WP GLOBE POLE	5,900.00
------------------------------	----------------------------	----------

SPECIAL REVENUE FUND (CONTINUED)

FIRE SPECIAL REVENUE

DETAILED CONSTRUCTION CO	PMT #1 2 ROOF TRAINING PROPS @ GFFR TRAINING CENTER	29,165.40
--------------------------	---	-----------

STREET DISTRICT

GREAT FALLS SAND & GRAVEL	PMT #3 OF 1611.1 / 2011 STREET REPAIRS REIMBURSEMENT FOR RECONSTRUCTION OF AN EXISTING PORTION OF 7TH AVE N ADJACENT TO COTTAGE GROVE ADDITION PHASE 3	222,206.37
DISCOVERY MEADOWS INC		33,780.50
UNITED MATERIALS OF GREAT FALLS	ASPHALTIC CONCRETE MATERIAL	71,770.30
NTL ENGINEERING & GEOSCIENCE	ANALYSIS ON ROAD FAILURE ON LOWER RIVER ROAD	9,000.00

NATURAL RESOURCES

DR LAWN LANDSCAPE SERVICE	REMOVAL OF 30 AMERICAN ELM TREES	20,325.00
---------------------------	----------------------------------	-----------

ENTERPRISE FUNDS

WATER

DANA KEPNER CO	664 - 3/4" SR II ECR/DM 100CF METERS	77,688.00
DANA KEPNER CO	636 - 3/4" SR II ECR/DM 100CF METERS	74,412.00
DANA KEPNER CO	50 - 1" SR II ECR/DM 100 CF METERS	7,750.00
DANA KEPNER CO	50 - 3/4" PMM ECR DM 100CF METERS	5,450.00
UNITED MATERIALS OF GREAT FALLS	FINAL OF 1599 PHASE II 1ST & 2ND AVE N WATER MAIN REPLACEMENT	62,736.40

SEWER

ARCADIS US INC	OF 1627 INDUSTRIAL WASTEWATER RATE STUDY	6,126.00
----------------	--	----------

STORM DRAIN

THOMAS DEAN & HOSKINS INC	OF 1617.1 NW GF SD IMPROVEMENTS PHASES 1-6 DESIGN & BIDDING	87,390.00
---------------------------	---	-----------

SANITATION

BISON MOTOR CO	2011 FORD F250 W/STAKE BODY	27,432.22
----------------	-----------------------------	-----------

ELECTRIC

SOUTHERN	BAL OF ENERGY SUPPLY EXPENSE JUL 11	11,776.01
DORSEY & WHITNEY LLP	PMT #22 OF 24 BOND COUNSEL SERVICES INCURRED PRIOR TO OCT 2007 NOW DUE	6,581.02

SWIM POOLS

WELLS FARGO CORPORATE TRUST	MITCHELL POOL DEBT SERVICE PMT	167,935.09
-----------------------------	--------------------------------	------------

INTERNAL SERVICES FUND

HEALTH & BENEFITS

BLUE CROSS/BLUE SHIELD	HEALTH INS CLAIMS AUGUST 30 - 31, 2011	34,100.61
BLUE CROSS/BLUE SHIELD	HEALTH INS CLAIMS SEPT 1 - 5, 2011	36,323.08
BLUE CROSS/BLUE SHIELD	HEALTH INS CLAIMS SEPT 6 - 12, 2011	111,748.47

INSURANCE & SAFETY

MONTANA MUNICIPAL INTERLOCAL AUTHORITY	AUGUST 2011 GENERAL LIABILITY DEDUCTIBLE RECOVERIES	8,784.41
---	--	----------

INFORMATION TECHNOLOGY

HEWLETT PACKARD CO	DL380G7 FOR CC VIRTUAL ENVIRONMENT FOR EXCHANGE 2010 UPGRADE	15,181.28
--------------------	---	-----------

CENTRAL GARAGE

MOUNTAIN VIEW CO-OP	FUEL	75,389.69
SUPERIOR TIRE INC	TIRES	16,210.40

TRUST AND AGENCY

COURT TRUST MUNICIPAL COURT

CITY OF GREAT FALLS	FINES & FORFEITURES COLLECTIONS	53,519.50
CASCADE COUNTY TREASURER	FINES & FORFEITURES COLLECTIONS	9,941.00

PAYROLL CLEARING

STATE TREASURER	MONTANA TAXES	40,862.00
ICMA RETIREMENT TRUST	EMPLOYEE CONTRIBUTIONS	11,110.55
FIREFIGHTER RETIREMENT	FIREFIGHTER RETIREMENT EMPLOYEE & EMPLOYER CONTRIBUTIONS	44,446.78
STATEWIDE POLICE RESERVE FUND	POLICE RETIREMENT EMPLOYEE & EMPLOYER CONTRIBUTIONS	53,656.23
PUBLIC EMPLOYEE RETIREMENT	PUBLIC EMPLOYEE RETIREMENT EMPLOYEE & EMPLOYER CONTRIBUTIONS	101,783.11
1ST INTERSTATE BANK	FEDERAL TAXES, FICA & MEDICARE	190,696.41
AFLAC	EMPLOYEE CONTRIBUTIONS	12,335.94
LABORERS INTERNATIONAL UNION	EMPLOYEE CONTRIBUTIONS	20,447.90
WESTERN CONF OF TEAMSTERS	EMPLOYEE CONTRIBUTIONS	15,682.55
MONTANA OE - CI TRUST FUND	EMPLOYEE CONTRIBUTIONS	18,334.82

UTILITY BILLS

NORTHWESTERN ENERGY	JULY 2011 CHARGES	31,315.83
MONTANA WASTE SYSTEMS INC	AUGUST 2011 CHARGES	85,004.25
ENERGY WEST RESOURCES	AUGUST 2011 CHARGES	14,326.46

CLAIMS OVER \$5000 TOTAL: \$ 2,059,032.53

City of Great Falls

Check Details Report (Date: 09/14/2011)

Account#	Check#	VendorName	Vendor#	Invoice#	Amount
6080-71-761-42230	217659	NORTHWEST PIPE FITTINGS INC	142	I12-003161	\$ 13.93
6080-71-761-42230	217659	NORTHWEST PIPE FITTINGS INC	142	I12-003162	\$ 45.48
6080-71-761-43420	217660	NORTHWESTERN ENERGY	82	I12-002877	\$ 42.90
6080-71-761-43420	217660	NORTHWESTERN ENERGY	82	I12-003079	\$ 1,664.05
6080-71-761-43415	217706	VERIZON WIRELESS	10858	I12-002928	\$ 22.61
6080-71-761-42230	217717	ACE HARDWARE	4876	I12-003369	\$ 29.98
6080-71-761-42230	217755	CASCADE MACHINE & SUPPLY	12753	I12-002819	\$ 4.95
6080-71-761-43430	217784	ENERGY WEST RESOURCES INC	83	I11-007335	\$ 243.83
6080-71-761-42230	217796	GERBERS OF MONTANA INC	66	I12-002818	\$ 4.49
6080-71-761-42230	217831	MONTANA BROOM & BRUSH COMPANY	7828	I12-003462	\$ 379.02

5735-64-646-43420	217660	NORTHWESTERN ENERGY	82	I12-002877	\$ 9.10
					Fund(6080) Total\$2,451.24

5310-31-565-49310	217560	ARCADIS US INC	13630	I12-002980	\$ 2,658.00
					Fund(5735) Total\$9.10
5310-31-565-49310	217560	ARCADIS US INC	13630	I12-002982	\$ 6,126.00
5310-31-565-49310	217624	HDR ENGINEERING INC	10970	I12-002971	\$ 2,000.00
5310-31-565-49310	217624	HDR ENGINEERING INC	10970	I12-002972	\$ 2,703.89
5310-31-565-42290	217635	JOHNSON MADISON LUMBER INC	9	I12-002941	\$ 29.98
5310-31-565-42120	217669	PICKWICK'S OFFICE WORKS INC	367	I12-002789	\$ 11.49
5310-31-565-43110	217684	SHIP-IT	137	I12-002792	\$ 33.05
5310-31-565-49310	217688	STELLING ENGINEERS INC	7872	I12-002929	\$ 738.28
5310-31-565-42340	217703	UNITED MATERIALS OF GREAT FALLS INC	121	I12-002798	\$ 145.75
5310-31-565-43415	217706	VERIZON WIRELESS	10858	I12-003191	\$ 193.05
5310-31-565-43590	217753	CASCADE COUNTY CLERK & RECORDER	130	I12-003440	\$ 14.00
5310-31-565-43590	217753	CASCADE COUNTY CLERK & RECORDER	130	I12-003440	\$ 14.00
5310-31-565-43445	217834	MONTANA WASTE SYSTEMS INC	8467	I12-003290	\$ 344.20
5310-31-565-49310	217840	MT DEPT OF REVENUE 1% WITHHOLDING	136	I12-003523	\$ 5.28
5310-31-565-49310	217840	MT DEPT OF REVENUE 1% WITHHOLDING	136	I12-003525	\$ 14.94
5310-31-565-49310	217859	PHILLIPS CONSTRUCTION	9122	I12-003521	\$ 523.07
5310-31-565-49310	217884	SHUMAKER TRUCKING & EXCAVATING	1096	I12-003524	\$ 1,478.87

City of Great Falls

Check Details Report (Date: 09/14/2011)

Account#	Check#	VendorName	Vendor#	Invoice#	Amount
CONT					

5710-32-195-43790	217641	MASTERCARD PROCESSING CENTER	8270	Fund(5310) Total I12-002496	\$17,033.85 \$ 343.17
5710-10-031-46320	217773	DORSEY & WHITNEY LLP (MINNESOTA)	3104	I12-003270	\$ 6,581.02
5710-32-195-43790	217820	JONES BOB	13639	I12-003539	\$ 244.20
5710-32-195-43590	217826	LAQUINTA INNS & SUITES GTF	11343	I12-003340	\$ 83.39
5710-32-195-43590	217826	LAQUINTA INNS & SUITES GTF	11343	I12-003342	\$ 83.39
5710-32-195-43790	217830	MASTERCARD PROCESSING CENTER	8270	I12-003526	\$ 95.30
5710-32-195-43590	217837	MOULTON BELLINGHAM PC	13512	I12-003481	\$ 1,871.54

5711-10-031-46150	0	WELLS FARGO CORPORATE TRUST SERVICES	13613	Fund(5710) Total I12-003395	\$9,302.01 \$ 121,713.05
5711-10-031-46250	0	WELLS FARGO CORPORATE TRUST SERVICES	13613	I12-003395	\$ 46,222.04
5711-64-671-43640	217554	ACE HARDWARE	4876	I12-002866	\$ 16.97
5711-64-673-42330	217580	CASCADE MACHINE & SUPPLY	12753	I12-002867	\$ 56.25
5711-64-673-42350	217635	JOHNSON MADISON LUMBER INC	9	I12-002869	\$ 138.89
5711-64-671-43340	217637	LAMAR COMPANIES (THE)	8380	I12-003008	\$ 500.00
5711-64-673-42350	217640	MASCO JANITORIAL SUPPLY	198	I12-002870	\$ 345.39
5711-64-673-42350	217640	MASCO JANITORIAL SUPPLY	198	I12-002872	\$ 5.94
5711-64-673-42290	217640	MASCO JANITORIAL SUPPLY	198	I12-002874	\$ 30.00
5711-64-671-43420	217660	NORTHWESTERN ENERGY	82	I12-002877	\$ 1,312.70
5711-64-673-43420	217660	NORTHWESTERN ENERGY	82	I12-003079	\$ 303.03
5711-64-673-43415	217706	VERIZON WIRELESS	10858	I12-003167	\$ 60.20
5711-64-671-42390	217717	ACE HARDWARE	4876	I12-003407	\$ 7.49
5711-64-673-42350	217717	ACE HARDWARE	4876	I12-003409	\$ 28.97
5711-64-671-42330	217717	ACE HARDWARE	4876	I12-003411	\$ 10.77
5711-64-671-42390	217717	ACE HARDWARE	4876	I12-003415	\$ 5.99
5711-64-671-42330	217717	ACE HARDWARE	4876	I12-003419	\$ 32.90
5711-64-673-42350	217764	CONSOLIDATED ELECTRICAL DIST INC	52	I12-003421	\$ 45.06
5711-64-673-42350	217764	CONSOLIDATED ELECTRICAL DIST INC	52	I12-003422	\$ 2.99

City of Great Falls

Check Details Report (Date: 09/14/2011)

Account#	Check#	VendorName	Vendor#	Invoice#	Amount
5711-64-671-43430	217784	ENERGY WEST RESOURCES INC	83	I11-007335	\$ 5,697.69
5711-64-673-43430	217784	ENERGY WEST RESOURCES INC	83	I11-007335	\$ 1,944.09
5711-64-675-43430	217784	ENERGY WEST RESOURCES INC	83	I11-007335	\$ 2,500.03
5711-64-673-42350	217798	GLACIER STATE ELECTRIC SUPPLY	67	I12-003308	\$ 17.00
5711-64-673-43610	217798	GLACIER STATE ELECTRIC SUPPLY	67	I12-003309	\$ 62.75
5711-64-673-43610	217818	JOHNSON MADISON LUMBER INC	9	I12-003429	\$ 11.15
5711-64-673-42350	217850	NORTHWEST PIPE FITTINGS INC	142	I12-003425	\$ 267.78
5711-64-673-42350	217850	NORTHWEST PIPE FITTINGS INC	142	I12-003428	\$ 21.67
5711-64-675-43420	217851	NORTHWESTERN ENERGY	82	I12-003253	\$ 243.72
5711-64-671-42190	217860	PICKWICK'S OFFICE WORKS INC	367	I12-003404	\$ 1.30
5711-64-673-42350	217865	PROBUILD	25	I12-003405	\$ 47.96

				Fund(5711) Total	\$181,653.77
2251-71-711-42190	217641	MASTERCARD PROCESSING CENTER	8270	I12-003117	\$ 1,120.71
2251-71-711-43590	217679	SANDERS, RION	12726	I12-003148	\$ 67.50
2251-71-711-43310	217692	TAYLOR & FRANCIS GROUP LLC CT	12361	I12-002935	\$ 411.00
2251-71-711-43310	217697	THOMSON WEST	7571	I12-002932	\$ 198.96
2251-71-711-43590	217711	WICKS DOUG	6030	I12-002946	\$ 2,000.00
2251-71-711-43330	217753	CASCADE COUNTY CLERK & RECORDER	130	I12-003440	\$ 14.00
2251-71-717-43590	217806	HIGH PLAINS ARCHITECTS PC	13631	I12-003358	\$ 2,550.03
2251-71-711-42190	217830	MASTERCARD PROCESSING CENTER	8270	I12-003414	\$ 13.65
2251-71-711-42190	217864	PRINTING CENTER	117	I12-003365	\$ 34.33

				Fund(2251) Total	\$6,410.18
5210-31-555-42390	217557	AMERICAN WELDING & GAS INC (VALLEY)	72	I12-002955	\$ 19.86
5210-31-556-42140	217572	BIG SKY FIRE/AFFIRMED MEDICAL	2129	I12-002936	\$ 46.20
5210-31-555-42390	217593	CRESCENT ELECTRIC SUPPLY CO	405	I12-002963	\$ 68.73
5210-31-556-49610	217594	DANA KEPNER COMPANY INC BILLINGS	4982	I12-002944	\$ 7,750.00
5210-31-556-49610	217594	DANA KEPNER COMPANY INC BILLINGS	4982	I12-002947	\$ 77,688.00
5210-31-556-49610	217594	DANA KEPNER COMPANY INC BILLINGS	4982	I12-002950	\$ 3,550.00
5210-31-556-49610	217594	DANA KEPNER COMPANY INC BILLINGS	4982	I12-002951	\$ 5,450.00

City of Great Falls

Check Details Report (Date: 09/14/2011)

Account#	Check#	VendorName	Vendor#	Invoice#	Amount
5210-31-556-49610	217594	DANA KEPNER COMPANY INC BILLINGS	4982	I12-002988	\$ 74,412.00
5210-31-555-42220	217601	DPC INDUSTRIES INC	301	I12-002964	\$ 3,688.80
5210-31-555-42220	217601	DPC INDUSTRIES INC	301	I12-002965	\$ 1,800.00
5210-00-000-21430	217604	EKERT, DUSTI, LAURIE & DON	1679	I12-003072	\$ 53.86
5210-31-555-42390	217608	FASTENAL COMPANY	7664	I12-002966	\$ 30.92
5210-31-555-42390	217608	FASTENAL COMPANY	7664	I12-002968	\$ 83.73
5210-31-555-42390	217608	FASTENAL COMPANY	7664	I12-002969	\$ 2.60
5210-31-553-43110	217610	FEDERAL EXPRESS CORPORATION	127	I12-002975	\$ 57.86
5210-00-000-21430	217612	FIRST INTERSTATE BANK	1679	I12-003183	\$ 7.35
5210-00-000-21430	217618	GRAY, JARED & AMBER	1679	I12-003182	\$ 93.50
5210-31-556-42290	217620	GREAT FALLS PAPER & SUPPLY CO	549	I12-002799	\$ 280.51
5210-31-556-42360	217623	HD SUPPLY WATERWORKS LTD	10091	I12-002934	\$ 2,174.26
5210-00-000-21430	217642	MCKEOWN, JAN	1679	I12-003181	\$ 44.31
5210-31-555-42390	217655	NAPA AUTO PARTS OF GREAT FALLS	68	I12-002979	\$ 53.78
5210-31-555-42390	217659	NORTHWEST PIPE FITTINGS INC	142	I12-002981	\$ 106.76
5210-31-555-43420	217660	NORTHWESTERN ENERGY	82	I12-002877	\$ 27.88
5210-31-555-43420	217660	NORTHWESTERN ENERGY	82	I12-003079	\$ 23,662.77
5210-31-556-42120	217669	PICKWICK'S OFFICE WORKS INC	367	I12-002938	\$ 223.99
5210-31-556-43210	217671	PRINTING CENTER	117	I12-002933	\$ 345.77
5210-31-553-43690	217673	QUALITY CONTROL SERVICES INC	1621	I12-002983	\$ 230.50
5210-31-556-42260	217683	SHINING MOUNTAIN IMAGES INC	6767	I12-002790	\$ 18.00
5210-31-556-43110	217684	SHIP-IT	137	I12-002793	\$ 13.88
5210-31-556-43110	217684	SHIP-IT	137	I12-002794	\$ 58.72
5210-31-556-49310	217688	STELLING ENGINEERS INC	7872	I12-002929	\$ 738.27
5210-31-555-42220	217694	THATCHER COMPANY OF MONTANA	2003	I12-002990	\$ 4,491.34
5210-31-556-42290	217701	TOOL BOX INC	2886	I12-002797	\$ 72.67
5210-31-556-42410	217701	TOOL BOX INC	2886	I12-002940	\$ 52.95
5210-31-556-42340	217702	TRIANGLE TURF FARMS INC	10824	I12-002796	\$ 352.50
5210-31-556-43412	217704	UTILITIES UNDERGROUND LOCATION CTR	3566	I12-002801	\$ 533.52
5210-31-555-43415	217706	VERIZON WIRELESS	10858	I12-003191	\$ 185.56

City of Great Falls

Check Details Report (Date: 09/14/2011)

Account#	Check#	VendorName	Vendor#	Invoice#	Amount
5210-31-556-43415	217706	VERIZON WIRELESS	10858	I12-003191	\$ 102.67
5210-31-556-42370	217707	VIRGINIA RUBBER CORPORATION	13321	I12-002930	\$ 14.36
5210-31-556-42370	217707	VIRGINIA RUBBER CORPORATION	13321	I12-002931	\$ 13.40
5210-31-555-42290	217717	ACE HARDWARE	4876	I12-003450	\$ 7.98
5210-31-555-43410	217726	AVAYA INC	6776	I12-003311	\$ 183.63
5210-31-555-43690	217729	BENTLEY SYSTEMS INC	11592	I12-003318	\$ 240.00
5210-31-555-42290	217745	BRODY CHEMICAL	6891	I12-003320	\$ 136.47
5210-31-555-42290	217745	BRODY CHEMICAL	6891	I12-003323	\$ 216.21
5210-31-555-42390	217765	CRESCENT ELECTRIC SUPPLY CO	405	I12-003324	\$ 107.10
5210-31-555-42350	217765	CRESCENT ELECTRIC SUPPLY CO	405	I12-003416	\$ 695.55
5210-31-555-42220	217776	DPC INDUSTRIES INC	301	I12-003430	\$ 6,496.80
5210-31-555-42220	217776	DPC INDUSTRIES INC	301	I12-003432	\$ -6,496.80
5210-31-555-42220	217776	DPC INDUSTRIES INC	301	I12-003433	\$ 3,688.80
5210-31-555-42220	217776	DPC INDUSTRIES INC	301	I12-003434	\$ 900.00
5210-31-555-43430	217784	ENERGY WEST RESOURCES INC	83	I11-007335	\$ 810.47
5210-31-555-42390	217785	FASTENAL COMPANY	7664	I12-003435	\$ 4.70
5210-31-555-42290	217786	FASTENERS INC	62	I12-003437	\$ 50.51
5210-31-555-42410	217786	FASTENERS INC	62	I12-003437	\$ 54.89
5210-31-553-43110	217787	FEDERAL EXPRESS CORPORATION	127	I12-003441	\$ 7.48
5210-31-555-42380	217794	GENERAL DISTRIBUTING CO	65	I12-003442	\$ 381.96
5210-31-555-42290	217794	GENERAL DISTRIBUTING CO	65	I12-003443	\$ 35.96
5210-31-555-42410	217798	GLACIER STATE ELECTRIC SUPPLY	67	I12-003444	\$ 10.49
5210-31-555-42290	217800	GREAT FALLS PAPER & SUPPLY CO	549	I12-003451	\$ 94.31
5210-31-555-42290	217812	INDUSTRIAL TOWEL & COVER SUPPLY CO	104	I12-003453	\$ 12.93
5210-31-555-42330	217830	MASTERCARD PROCESSING CENTER	8270	I12-003447	\$ 541.38
5210-31-556-49310	217839	MT DEPT OF ENVIRONMENTAL QUALITY WA	6873	I12-003282	\$ 805.00
5210-31-556-49310	217840	MT DEPT OF REVENUE 1% WITHHOLDING	136	I12-003523	\$ 8.77
5210-31-556-49310	217840	MT DEPT OF REVENUE 1% WITHHOLDING	136	I12-003528	\$ 633.70
5210-31-555-42290	217846	NATIONAL LAUNDRY	388	I12-003454	\$ 117.36

City of Great Falls

Check Details Report (Date: 09/14/2011)

Account#	Check#	VendorName	Vendor#	Invoice#	Amount
5210-31-555-42390	217850	NORTHWEST PIPE FITTINGS INC	142	I12-003455	\$ 110.10
5210-31-555-43420	217851	NORTHWESTERN ENERGY	82	I12-003253	\$ 8.82
5210-31-556-49310	217859	PHILLIPS CONSTRUCTION	9122	I12-003521	\$ 867.80
5210-31-555-42330	217861	POLYCHEM SYSTEMS	13343	I12-003456	\$ 1,441.14
5210-31-555-42290	217865	PROBUILD	25	I12-003459	\$ 11.98
5210-31-556-43735	217868	PROSPECTOR RESTAURANT BE	6520	I12-003255	\$ 9.95
5210-31-556-43735	217868	PROSPECTOR RESTAURANT BE	6520	I12-003255	\$ 10.94
5210-31-556-43735	217868	PROSPECTOR RESTAURANT BE	6520	I12-003255	\$ 10.94
5210-31-556-43735	217868	PROSPECTOR RESTAURANT BE	6520	I12-003255	\$ 11.45
5210-31-556-43735	217868	PROSPECTOR RESTAURANT BE	6520	I12-003255	\$ 10.94
5210-31-556-43735	217868	PROSPECTOR RESTAURANT BE	6520	I12-003255	\$ -1.99
5210-31-555-42330	217885	SIEMENS INDUSTRY INC	13634	I12-003237	\$ 1,555.73
5210-31-555-42390	217887	SMITH EQUIPMENT CO	2317	I12-003461	\$ 8.50
5210-00-000-21430	217890	SOUTHPARK HOMEOWNERS ASSN INC	1679	I12-003516	\$ 10.98
5210-31-555-42220	217898	THATCHER COMPANY OF MONTANA	2003	I12-003464	\$ 4,402.66
5210-31-555-42410	217906	TOOL BOX INC	2886	I12-003465	\$ 43.40
5210-31-555-42410	217906	TOOL BOX INC	2886	I12-003468	\$ 63.00
5210-31-556-49310	217909	UNITED MATERIALS OF GREAT FALLS INC	121	I12-003527	\$ 62,736.40

2310-15-211-47360	217619	GREAT FALLS DEVELOPMENT AUTHORITY	3314	Fund(5210) Total I12-003184	\$289,660.17 \$ 70,000.00

4001-64-621-49310	217801	GREAT FALLS SAND & GRAVEL INC	99	Fund(2310) Total I12-003530	\$70,000.00 \$ 4,116.62
4001-64-621-49310	217840	MT DEPT OF REVENUE 1% WITHHOLDING	136	I12-003531	\$ 41.58

2320-71-761-43430	217784	ENERGY WEST RESOURCES INC	83	Fund(4001) Total I11-007335	\$4,158.20 \$ 17.00

5010-64-653-43510	217555	ALARM SERVICE INC	177	Fund(2320) Total I12-003124	\$17.00 \$ 50.00
5010-64-651-43510	217555	ALARM SERVICE INC	177	I12-003130	\$ 50.00
5010-00-000-15121	217561	ARCANE EYEWEAR	13628	I12-002884	\$ 513.00

City of Great Falls

Check Details Report (Date: 09/14/2011)

Account#	Check#	VendorName	Vendor#	Invoice#	Amount
5010-64-651-43410	217585	CENTURYLINK - QWEST CORPORATION	81	I12-003142	\$ 193.46
5010-64-653-43410	217585	CENTURYLINK - QWEST CORPORATION	81	I12-003143	\$ 219.12
5010-64-652-43620	217600	DOORS & HARDWARE UNLIMITED INC	6731	I12-002921	\$ 45.00
5010-64-652-42290	217613	FLEET SUPPLY COMPANY	64	I12-002915	\$ 8.97
5010-00-000-15121	217614	FOOTJOY	12664	I12-002881	\$ 1,395.94
5010-64-653-43210	217617	Golf Scorecards, Inc.	12646	I12-002886	\$ 271.70
5010-64-653-42350	217635	JOHNSON MADISON LUMBER INC	9	I12-002998	\$ 14.95
5010-64-651-43210	217637	LAMAR COMPANIES (THE)	8380	I12-003006	\$ 325.00
5010-64-653-43210	217637	LAMAR COMPANIES (THE)	8380	I12-003006	\$ 325.00
5010-64-651-43210	217637	LAMAR COMPANIES (THE)	8380	I12-003008	\$ 250.00
5010-64-653-43210	217637	LAMAR COMPANIES (THE)	8380	I12-003008	\$ 250.00
5010-64-653-42230	217640	MASCO JANITORIAL SUPPLY	198	I12-002996	\$ 312.47
5010-64-651-42230	217640	MASCO JANITORIAL SUPPLY	198	I12-003001	\$ 49.98
5010-64-653-42230	217640	MASCO JANITORIAL SUPPLY	198	I12-003004	\$ 53.55
5010-64-654-42330	217644	MIDLAND IMPLEMENT COMPANY INC	106	I12-002916	\$ 288.78
5010-64-654-42330	217644	MIDLAND IMPLEMENT COMPANY INC	106	I12-002918	\$ 11.05
5010-64-654-43430	217652	MOUNTAIN VIEW CO-OP	972	I12-003173	\$ 55.00
5010-64-651-42230	217657	NATIONAL LAUNDRY	388	I12-002992	\$ 25.13
5010-64-653-42230	217657	NATIONAL LAUNDRY	388	I12-002993	\$ 90.84
5010-64-652-43420	217660	NORTHWESTERN ENERGY	82	I12-002877	\$ 2.09
5010-64-654-43420	217660	NORTHWESTERN ENERGY	82	I12-002877	\$ 1,054.06
5010-64-652-42290	217672	PROBUILD	25	I12-002914	\$ 28.97
5010-64-654-42220	217685	SOUTHWEST TURF INC	12075	I12-002920	\$ 364.03
5010-64-651-42350	217693	TC GLASS DISTRIBUTOR INC	34	I12-002907	\$ 752.72
5010-00-000-15121	217695	The Resourceful Bean, LLC	12646	I12-002888	\$ 428.04
5010-64-653-42330	217698	TIRE FACTORY	9864	I12-002991	\$ 15.00
5010-00-000-15121	217700	TITLEIST	6713	I12-002883	\$ 434.91
5010-64-652-43415	217706	VERIZON WIRELESS	10858	I12-003167	\$ 45.26
5010-64-654-43415	217706	VERIZON WIRELESS	10858	I12-003167	\$ 72.26
5010-64-653-43415	217706	VERIZON WIRELESS	10858	I12-003167	\$ 37.54

City of Great Falls

Check Details Report (Date: 09/14/2011)

Account#	Check#	VendorName	Vendor#	Invoice#	Amount
5010-64-651-43415	217706	VERIZON WIRELESS	10858	I12-003167	\$ 37.53
5010-64-654-42220	217712	WILBUR-ELLIS COMPANY	1652	I12-002922	\$ 80.00
5010-64-654-42220	217712	WILBUR-ELLIS COMPANY	1652	I12-002986	\$ 270.50
5010-64-654-42220	217712	WILBUR-ELLIS COMPANY	1652	I12-002986	\$ 351.40
5010-00-000-15121	217748	CALLAWAY GOLF SALES CO	13615	I12-003234	\$ 384.00
5010-00-000-15121	217748	CALLAWAY GOLF SALES CO	13615	I12-003241	\$ 837.00
5010-64-651-43430	217784	ENERGY WEST RESOURCES INC	83	I11-007335	\$ 17.00
5010-64-652-43430	217784	ENERGY WEST RESOURCES INC	83	I11-007335	\$ 44.24
5010-64-653-43430	217784	ENERGY WEST RESOURCES INC	83	I11-007335	\$ 20.44
5010-64-654-43420	217851	NORTHWESTERN ENERGY	82	I12-003248	\$ 769.70
5010-64-652-43420	217851	NORTHWESTERN ENERGY	82	I12-003248	\$ 1,278.06
5010-64-652-43420	217851	NORTHWESTERN ENERGY	82	I12-003248	\$ 673.58
5010-64-652-43420	217851	NORTHWESTERN ENERGY	82	I12-003248	\$ 258.18
5010-64-654-43420	217851	NORTHWESTERN ENERGY	82	I12-003253	\$ 248.61
5010-64-654-43420	217851	NORTHWESTERN ENERGY	82	I12-003253	\$ 135.83
5010-64-653-42290	217853	O & M GOLF - THRIFTY GOLF SUPPLY	13163	I12-003243	\$ 374.68
5010-00-000-15121	217853	O & M GOLF - THRIFTY GOLF SUPPLY	13163	I12-003243	\$ 595.97
5010-00-000-15121	217853	O & M GOLF - THRIFTY GOLF SUPPLY	13163	I12-003581	\$ 543.13
5010-00-000-15121	217893	SUN MOUNTAIN	11790	I12-003582	\$ 453.76

6065-15-261-43410	217585	CENTURYLINK - QWEST CORPORATION	81	Fund(5010) Total I12-002822	\$15,407.43 \$ 22.17
6065-15-264-43410	217585	CENTURYLINK - QWEST CORPORATION	81	I12-002822	\$ 22.17
6065-15-261-43630	217589	COMPUTER SOFTWARE ASSOCIATES INC	12645	I12-003025	\$ 406.00
6065-15-264-43110	217629	INNOVATIVE POSTAL SERVICE INC	7796	I12-002908	\$ 10.16
6065-15-264-43210	217629	INNOVATIVE POSTAL SERVICE INC	7796	I12-002908	\$ 5.89
6065-15-268-43110	217629	INNOVATIVE POSTAL SERVICE INC	7796	I12-003026	\$ 55.35
6065-15-268-43110	217629	INNOVATIVE POSTAL SERVICE INC	7796	I12-003027	\$ 91.66
6065-15-268-43110	217629	INNOVATIVE POSTAL SERVICE INC	7796	I12-003028	\$ 205.00
6065-15-268-43110	217629	INNOVATIVE POSTAL SERVICE INC	7796	I12-003029	\$ 129.28
6065-15-268-43110	217629	INNOVATIVE POSTAL SERVICE INC	7796	I12-003030	\$ 74.50

City of Great Falls

Check Details Report (Date: 09/14/2011)

Account#	Check#	VendorName	Vendor#	Invoice#	Amount
6065-15-261-42190	217669	PICKWICK'S OFFICE WORKS INC	367	I12-002909	\$ 14.31
6065-15-262-42190	217669	PICKWICK'S OFFICE WORKS INC	367	I12-002909	\$ 14.31
6065-15-264-42190	217669	PICKWICK'S OFFICE WORKS INC	367	I12-002909	\$ 1.59
6065-15-268-43590	217677	RICK'S DELIVERY LLC	13373	I12-002953	\$ 820.00
6065-15-268-43590	217677	RICK'S DELIVERY LLC	13373	I12-002953	\$ 49.20
6065-15-261-43590	217753	CASCADE COUNTY CLERK & RECORDER	130	I12-003440	\$ 35.00
6065-15-264-43590	217793	GARDA CL NORTHWEST INC	12759	I12-003344	\$ 902.54
6065-15-264-43110	217813	INNOVATIVE POSTAL SERVICE INC	7796	I12-003345	\$ 16.77
6065-15-264-43210	217813	INNOVATIVE POSTAL SERVICE INC	7796	I12-003345	\$ 4.94
6065-15-268-43110	217813	INNOVATIVE POSTAL SERVICE INC	7796	I12-003626	\$ 195.13
6065-15-268-43110	217813	INNOVATIVE POSTAL SERVICE INC	7796	I12-003627	\$ 107.36
6065-15-268-43110	217813	INNOVATIVE POSTAL SERVICE INC	7796	I12-003628	\$ 150.21
6065-15-268-43110	217813	INNOVATIVE POSTAL SERVICE INC	7796	I12-003629	\$ 79.35
6065-15-268-43110	217813	INNOVATIVE POSTAL SERVICE INC	7796	I12-003630	\$ 191.28

2440-31-536-43690	217908	UNITED ELECTRIC LLC	12906	Fund(6065) Total I12-003492	\$3,604.17 \$ 778.43

2956-71-712-49310	217828	LIBERTY ELECTRIC INC	5408	Fund(2440) Total I12-003203	\$778.43 \$ 18,059.82
2956-71-712-49310	217840	MT DEPT OF REVENUE 1% WITHHOLDING	136	I12-003204	\$ 182.42

6060-21-151-43410	217674	QWEST COMMUNICATIONS COMPANY LLC	9903	Fund(2956) Total I12-002863	\$18,242.24 \$ 503.56

5740-64-691-42290	217641	MASTERCARD PROCESSING CENTER	8270	Fund(6060) Total I12-003022	\$503.56 \$ 23.60
5740-64-691-42190	217641	MASTERCARD PROCESSING CENTER	8270	I12-003023	\$ 51.98
5740-64-693-43980	217657	NATIONAL LAUNDRY	388	I12-003017	\$ 167.90
5740-64-691-42290	217672	PROBUILD	25	I12-003020	\$ 38.13
5740-00-000-21480	217681	Shawn Hertel & Kristal Coltran	12731	I12-003018	\$ 143.25
5740-00-000-21480	217682	Shelly Christiaens	12731	I12-003019	\$ 85.00
5740-64-691-43415	217706	VERIZON WIRELESS	10858	I12-003021	\$ 39.03

City of Great Falls

Check Details Report (Date: 09/14/2011)

Account#	Check#	VendorName	Vendor#	Invoice#	Amount
5740-64-691-42290	217774	DOUBLE G ENGRAVING & AWARDS	5178	I12-003501	\$ 68.40
5740-64-693-43980	217846	NATIONAL LAUNDRY	388	I12-003505	\$ 77.19
5740-64-691-42190	217891	STAPLES ADVANTAGE	13227	I12-003509	\$ 5.23
5740-64-691-42190	217891	STAPLES ADVANTAGE	13227	I12-003511	\$ 38.72

					Fund(5740) Total\$738.43
4510-71-721-43590	217753	CASCADE COUNTY CLERK & RECORDER	130	I12-003440	\$ 6.25

					Fund(4510) Total\$6.25
2855-21-311-43590	217554	ACE HARDWARE	4876	I12-002856	\$ 106.81
2855-21-318-43415	217910	VERIZON WIRELESS	10858	I12-003272	\$ 137.16
2855-21-391-43590	217910	VERIZON WIRELESS	10858	I12-003272	\$ 1,441.21
2855-21-391-43590	217910	VERIZON WIRELESS	10858	I12-003274	\$ 287.98
2855-21-318-43415	217910	VERIZON WIRELESS	10858	I12-003275	\$ 74.58

					Fund(2855) Total\$2,047.74
2398-71-727-42290	217830	MASTERCARD PROCESSING CENTER	8270	I12-003414	\$ 8.66

					Fund(2398) Total\$8.66
2520-31-531-42290	217554	ACE HARDWARE	4876	I12-002804	\$ 74.99
2520-31-536-43410	217585	CENTURYLINK - QWEST CORPORATION	81	I12-003024	\$ 50.81
2520-31-531-43410	217585	CENTURYLINK - QWEST CORPORATION	81	I12-003024	\$ 50.81
2520-31-531-42290	217588	COLUMBIA PAINT & COATINGS	50	I12-002809	\$ 49.47
2520-31-531-43690	217590	CONCRETE DOCTOR INC	10508	I12-002802	\$ 645.00
2520-31-531-43690	217599	DISCOVERY MEADOWS INC	13633	I12-003185	\$ 33,780.50
2520-31-531-49310	217621	GREAT FALLS SAND & GRAVEL INC	99	I12-003033	\$ 222,206.37
2520-31-531-42290	217635	JOHNSON MADISON LUMBER INC	9	I12-002805	\$ 15.95
2520-31-531-49310	217653	MT DEPT OF REVENUE 1% WITHHOLDING	136	I12-003034	\$ 2,244.51
2520-31-531-43630	217657	NATIONAL LAUNDRY	388	I12-003126	\$ 21.49
2520-31-531-42290	217658	NORMONT EQUIPMENT CO	15	I12-002806	\$ 40.00
2520-31-531-42290	217658	NORMONT EQUIPMENT CO	15	I12-003192	\$ 30.00
2520-31-531-43420	217660	NORTHWESTERN ENERGY	82	I12-002877	\$ 17.18
2520-31-536-43420	217660	NORTHWESTERN ENERGY	82	I12-002877	\$ 192.90
2520-31-531-49325	217661	NTL ENGINEERING & GEOSCIENCE	3546	I12-003123	\$ 9,000.00

City of Great Falls

Check Details Report (Date: 09/14/2011)

Account#	Check#	VendorName	Vendor#	Invoice#	Amount
2520-31-536-42430	217664	PACIFIC INNOVATIONS ENTERPRISE	13629	I12-002868	\$ 179.75
2520-31-536-42430	217664	PACIFIC INNOVATIONS ENTERPRISE	13629	I12-002868	\$ 21.95
2520-31-536-42430	217664	PACIFIC INNOVATIONS ENTERPRISE	13629	I12-002868	\$ 43.90
2520-31-536-42430	217664	PACIFIC INNOVATIONS ENTERPRISE	13629	I12-002868	\$ 41.45
2520-31-536-42190	217669	PICKWICK'S OFFICE WORKS INC	367	I12-003187	\$ 5.85
2520-31-531-42190	217669	PICKWICK'S OFFICE WORKS INC	367	I12-003187	\$ 5.86
2520-31-531-42290	217670	POWER PRO EQUIPMENT CO	8197	I12-003179	\$ 52.80
2520-31-531-43690	217678	S & H ALUMINUM PRODUCTS INC	3725	I12-002808	\$ 946.94
2520-31-531-42390	217703	UNITED MATERIALS OF GREAT FALLS INC	121	I12-003180	\$ 8,801.26
2520-31-531-42390	217703	UNITED MATERIALS OF GREAT FALLS INC	121	I12-003180	\$ 483.00
2520-31-531-42390	217703	UNITED MATERIALS OF GREAT FALLS INC	121	I12-003195	\$ 14,683.20
2520-31-531-42390	217703	UNITED MATERIALS OF GREAT FALLS INC	121	I12-003195	\$ 313.95
2520-31-531-42390	217703	UNITED MATERIALS OF GREAT FALLS INC	121	I12-003197	\$ 12,859.20
2520-31-531-42390	217703	UNITED MATERIALS OF GREAT FALLS INC	121	I12-003197	\$ 169.05
2520-31-531-42390	217703	UNITED MATERIALS OF GREAT FALLS INC	121	I12-003200	\$ 8,185.20
2520-31-531-42390	217703	UNITED MATERIALS OF GREAT FALLS INC	121	I12-003202	\$ 7,774.80
2520-31-531-42390	217703	UNITED MATERIALS OF GREAT FALLS INC	121	I12-003202	\$ 193.20
2520-31-531-43415	217706	VERIZON WIRELESS	10858	I12-003191	\$ 210.97
2520-31-536-43415	217706	VERIZON WIRELESS	10858	I12-003191	\$ 143.94
2520-31-536-42290	217717	ACE HARDWARE	4876	I12-003494	\$ 9.98
2520-31-531-42290	217732	BIG SKY FIRE/AFFIRMED MEDICAL	2129	I12-003495	\$ 191.37
2520-31-536-43630	217732	BIG SKY FIRE/AFFIRMED MEDICAL	2129	I12-003579	\$ 5.29
2520-31-531-42290	217732	BIG SKY FIRE/AFFIRMED MEDICAL	2129	I12-003579	\$ 5.30
2520-31-531-42290	217736	BLENDS COPY SHOP INC	43	I12-003490	\$ 26.00
2520-31-531-42290	217736	BLENDS COPY SHOP INC	43	I12-003491	\$ 35.00
2520-31-531-43590	217753	CASCADE COUNTY CLERK & RECORDER	130	I12-003440	\$ 14.00
2520-31-536-42290	217762	COLUMBIA PAINT & COATINGS	50	I12-003493	\$ 46.00
2520-31-536-42435	217838	MOUNTAIN VIEW CO-OP	972	I12-003489	\$ 29.37
2520-31-531-42290	217849	NORMONT EQUIPMENT CO	15	I12-003567	\$ 618.00
2520-31-531-43420	217851	NORTHWESTERN ENERGY	82	I12-003253	\$ 18.08

City of Great Falls

Check Details Report (Date: 09/14/2011)

Account#	Check#	VendorName	Vendor#	Invoice#	Amount
2520-31-536-42190	217860	PICKWICK'S OFFICE WORKS INC	367	I12-003449	\$ 12.66
2520-31-531-42190	217860	PICKWICK'S OFFICE WORKS INC	367	I12-003449	\$ 12.67
2520-31-536-42290	217860	PICKWICK'S OFFICE WORKS INC	367	I12-003540	\$ 89.99
2520-31-531-42290	217862	POWER PRO EQUIPMENT CO	8197	I12-003211	\$ 8.00
2520-31-531-43690	217892	STROBELS RENTALS INC	32	I12-003209	\$ 225.00
2520-31-531-43690	217892	STROBELS RENTALS INC	32	I12-003210	\$ 225.00
2520-31-531-49325	217899	THOMAS DEAN & HOSKINS INC	119	I12-003460	\$ 211.50
2520-31-531-42390	217909	UNITED MATERIALS OF GREAT FALLS INC	121	I12-003543	\$ 5,289.60
2520-31-531-42390	217909	UNITED MATERIALS OF GREAT FALLS INC	121	I12-003543	\$ 241.50
2520-31-531-42390	217909	UNITED MATERIALS OF GREAT FALLS INC	121	I12-003544	\$ 12,186.60
2520-31-531-42390	217909	UNITED MATERIALS OF GREAT FALLS INC	121	I12-003544	\$ 589.74

3101-10-031-46310	0	U S BANK NATIONAL ASSOCIATION	13539	Fund(2520) Total I12-003399	\$343,626.90 \$ 300.00

2220-61-611-42390	217554	ACE HARDWARE	4876	Fund(3101) Total I12-003153	\$300.00 \$ 3.99
2220-61-611-43320	217563	BAKER & TAYLOR INC	4335	I12-003081	\$ 23.16
2220-61-611-43320	217564	BARNES & NOBLE BOOKSELLERS INC	5643	I12-003086	\$ 139.17
2220-61-611-43320	217564	BARNES & NOBLE BOOKSELLERS INC	5643	I12-003087	\$ 12.76
2220-61-611-43320	217578	BRODART COMPANY	92	I12-002997	\$ 13.89
2220-61-611-43320	217578	BRODART COMPANY	92	I12-002999	\$ 90.91
2220-61-611-43320	217578	BRODART COMPANY	92	I12-003000	\$ 13.15
2220-61-611-43320	217578	BRODART COMPANY	92	I12-003003	\$ 17.19
2220-61-611-43320	217578	BRODART COMPANY	92	I12-003005	\$ 31.69
2220-61-611-43320	217578	BRODART COMPANY	92	I12-003007	\$ 62.41
2220-61-611-43320	217578	BRODART COMPANY	92	I12-003009	\$ 85.09
2220-61-611-43320	217578	BRODART COMPANY	92	I12-003011	\$ 100.09
2220-61-611-43320	217578	BRODART COMPANY	92	I12-003015	\$ 127.29
2220-61-611-43320	217578	BRODART COMPANY	92	I12-003015	\$ 38.94
2220-61-611-43320	217578	BRODART COMPANY	92	I12-003082	\$ 153.87
2220-61-611-43320	217578	BRODART COMPANY	92	I12-003133	\$ 113.72

City of Great Falls

Check Details Report (Date: 09/14/2011)

Account#	Check#	VendorName	Vendor#	Invoice#	Amount
2220-61-611-43320	217578	BRODART COMPANY	92	I12-003135	\$ 66.37
2220-61-611-43320	217578	BRODART COMPANY	92	I12-003136	\$ 37.62
2220-61-611-43320	217578	BRODART COMPANY	92	I12-003138	\$ 49.16
2220-61-611-43320	217578	BRODART COMPANY	92	I12-003139	\$ 33.26
2220-61-611-43320	217578	BRODART COMPANY	92	I12-003141	\$ 63.99
2220-61-611-43412	217581	CELLULAR ONE	10650	I12-003169	\$ 15.00
2220-61-611-43320	217582	CENTER POINT PUBLISHING	8335	I12-003088	\$ 40.48
2220-61-611-43410	217585	CENTURYLINK - QWEST CORPORATION	81	I12-003176	\$ 347.77
2220-61-611-42110	217598	DEMCO INC	277	I12-003154	\$ 296.85
2220-61-611-43620	217605	ENTERPRISE ELECTRIC INC	2370	I12-003155	\$ 634.86
2220-61-611-43320	217615	GALE GROUP	2250	I12-002994	\$ 44.99
2220-61-611-43320	217615	GALE GROUP	2250	I12-002995	\$ 181.46
2220-61-611-43320	217615	GALE GROUP	2250	I12-003012	\$ 19.47
2220-61-611-43210	217636	KELLY'S SIGNS	3426	I12-003146	\$ 28.00
2220-61-611-42390	217640	MASCO JANITORIAL SUPPLY	198	I12-003158	\$ 108.33
2220-61-611-42190	217641	MASTERCARD PROCESSING CENTER	8270	I12-003177	\$ 60.89
2220-61-611-43790	217641	MASTERCARD PROCESSING CENTER	8270	I12-003177	\$ 23.74
2220-61-611-43320	217641	MASTERCARD PROCESSING CENTER	8270	I12-003177	\$ 65.36
2220-61-611-43320	217641	MASTERCARD PROCESSING CENTER	8270	I12-003177	\$ 145.31
2220-61-611-42390	217657	NATIONAL LAUNDRY	388	I12-003151	\$ 19.55
2220-61-611-43620	217659	NORTHWEST PIPE FITTINGS INC	142	I12-003145	\$ 22.70
2220-61-611-43420	217660	NORTHWESTERN ENERGY	82	I12-003079	\$ 1,243.15
2220-61-611-42110	217686	STAPLES CREDIT PLAN-2414	8657	I12-003150	\$ 99.54
2220-61-611-43320	217696	THOMAS BOUREGY & CO INC	8263	I12-003085	\$ 34.40
2220-61-611-42390	217720	AMSAN	47	I12-003368	\$ 97.98
2220-61-611-43320	217744	BRODART COMPANY	92	I12-003013	\$ 242.96
2220-61-611-43320	217744	BRODART COMPANY	92	I12-003013	\$ 33.91
2220-61-611-43320	217744	BRODART COMPANY	92	I12-003482	\$ 45.18
2220-61-611-43320	217744	BRODART COMPANY	92	I12-003483	\$ 242.06
2220-61-611-43320	217744	BRODART COMPANY	92	I12-003484	\$ 199.50

City of Great Falls

Check Details Report (Date: 09/14/2011)

Account#	Check#	VendorName	Vendor#	Invoice#	Amount
2220-61-611-43320	217744	BRODART COMPANY	92	I12-003486	\$ 18.09
2220-61-611-43320	217744	BRODART COMPANY	92	I12-003587	\$ 45.20
2220-61-611-43320	217744	BRODART COMPANY	92	I12-003589	\$ 24.38
2220-61-611-43320	217744	BRODART COMPANY	92	I12-003590	\$ 34.14
2220-61-611-43320	217744	BRODART COMPANY	92	I12-003591	\$ 146.96
2220-61-611-43320	217744	BRODART COMPANY	92	I12-003595	\$ 110.10
2220-61-611-43320	217744	BRODART COMPANY	92	I12-003610	\$ 33.54
2220-61-611-43320	217744	BRODART COMPANY	92	I12-003613	\$ 130.79
2220-61-611-43320	217744	BRODART COMPANY	92	I12-003614	\$ 13.90
2220-61-611-43320	217744	BRODART COMPANY	92	I12-003615	\$ 106.93
2220-61-611-43320	217744	BRODART COMPANY	92	I12-003616	\$ 35.09
2220-61-611-43320	217761	CHOTEAU ACANTHA PUBLISHING INC	9755	I12-003618	\$ 37.00
2220-61-611-42390	217763	Concepts Unlimited, Inc	12978	I12-003609	\$ 243.00
2220-61-611-43630	217767	DAVIS BUSINESS MACHINES	293	I12-003620	\$ 217.00
2220-61-611-43430	217784	ENERGY WEST RESOURCES INC	83	I11-007335	\$ 132.80
2220-61-611-42190	217830	MASTERCARD PROCESSING CENTER	8270	I12-003585	\$ 162.41
2220-61-611-43350	217833	Montana Library Association	12978	I12-003374	\$ 80.00
2220-61-611-42390	217862	POWER PRO EQUIPMENT CO	8197	I12-003370	\$ 16.35
2220-61-611-42390	217862	POWER PRO EQUIPMENT CO	8197	I12-003619	\$ 40.10
2220-61-611-42120	217867	PROPERTY & SUPPLY BUREAU ST OF MT	621	I12-003366	\$ 142.50
2220-61-611-43412	217889	SOFTWORX INC	5124	I12-003621	\$ 188.00
2220-61-611-43320	217900	THRASHER MAGAZINE	12978	I12-003617	\$ 17.95

Fund(2220) Total					\$7,547.39
2394-71-728-43415	217706	VERIZON WIRELESS	10858	I12-002928	\$ 300.31
2394-71-728-43415	217706	VERIZON WIRELESS	10858	I12-003166	\$ 245.48
2394-71-728-42290	217716	A TO Z LOCK & KEY	1849	I12-003463	\$ 3.55
2394-71-728-42290	217830	MASTERCARD PROCESSING CENTER	8270	I12-003414	\$ 15.50
2394-71-728-43390	217832	MONTANA INTERACTIVE LLC	12485	I12-003379	\$ 33.75
2394-71-728-42290	217864	PRINTING CENTER	117	I12-003365	\$ 34.33

Fund(2394) Total					\$632.92

City of Great Falls

Check Details Report (Date: 09/14/2011)

Account#	Check#	VendorName	Vendor#	Invoice#	Amount
2221-61-613-43320	217563	BAKER & TAYLOR INC	4335	I12-003080	\$ 101.32
2221-61-613-43320	217563	BAKER & TAYLOR INC	4335	I12-003089	\$ 94.55
2221-61-613-43320	217564	BARNES & NOBLE BOOKSELLERS INC	5643	I12-003087	\$ 11.96
2221-61-613-43320	217564	BARNES & NOBLE BOOKSELLERS INC	5643	I12-003087	\$ 47.08
2221-61-613-43320	217578	BRODART COMPANY	92	I12-002997	\$ 13.89
2221-61-613-43320	217578	BRODART COMPANY	92	I12-003002	\$ 193.75
2221-61-613-43320	217578	BRODART COMPANY	92	I12-003003	\$ 15.13
2221-61-613-43320	217578	BRODART COMPANY	92	I12-003005	\$ 64.87
2221-61-613-43320	217578	BRODART COMPANY	92	I12-003007	\$ 86.22
2221-61-613-43320	217578	BRODART COMPANY	92	I12-003083	\$ 156.56
2221-61-613-43320	217578	BRODART COMPANY	92	I12-003084	\$ 127.88
2221-61-613-43320	217578	BRODART COMPANY	92	I12-003133	\$ 56.77
2221-61-613-43320	217578	BRODART COMPANY	92	I12-003139	\$ 16.91
2221-61-613-43320	217578	BRODART COMPANY	92	I12-003141	\$ 125.13
2221-61-613-43945	217603	EASTER SEALS/GOODWILL NORTHERN ROCK	4028	I12-003168	\$ 83.70
2221-61-613-43945	217641	MASTERCARD PROCESSING CENTER	8270	I12-003177	\$ 60.00
2221-61-613-43945	217645	MIDTOWN PERKINS / MOTEL	5516	I12-003156	\$ 58.78
2221-61-613-43945	217668	Pexagon Technology	12978	I12-003147	\$ 237.00
2221-61-613-43945	217676	RECORDED BOOKS LLC	10204	I12-003159	\$ 33.00
2221-61-613-43945	217676	RECORDED BOOKS LLC	10204	I12-003164	\$ 33.00
2221-61-613-43945	217676	RECORDED BOOKS LLC	10204	I12-003165	\$ 33.00
2221-61-613-43320	217744	BRODART COMPANY	92	I12-003013	\$ 171.62
2221-61-613-43320	217744	BRODART COMPANY	92	I12-003482	\$ 161.53
2221-61-613-43320	217744	BRODART COMPANY	92	I12-003483	\$ 24.65
2221-61-613-43320	217744	BRODART COMPANY	92	I12-003484	\$ 89.85
2221-61-613-43320	217744	BRODART COMPANY	92	I12-003485	\$ 35.30
2221-61-613-43320	217744	BRODART COMPANY	92	I12-003486	\$ 18.09
2221-61-613-43320	217744	BRODART COMPANY	92	I12-003487	\$ 58.90
2221-61-613-43320	217744	BRODART COMPANY	92	I12-003488	\$ 51.98

City of Great Falls

Check Details Report (Date: 09/14/2011)

Account#	Check#	VendorName	Vendor#	Invoice#	Amount
2221-61-613-43320	217744	BRODART COMPANY	92	I12-003586	\$ 19.00
2221-61-613-43320	217744	BRODART COMPANY	92	I12-003588	\$ 18.90
2221-61-613-43320	217744	BRODART COMPANY	92	I12-003590	\$ 120.04
2221-61-613-43320	217744	BRODART COMPANY	92	I12-003591	\$ 70.94
2221-61-613-43320	217744	BRODART COMPANY	92	I12-003592	\$ 20.66
2221-61-613-43320	217744	BRODART COMPANY	92	I12-003595	\$ 34.32
2221-61-613-43320	217744	BRODART COMPANY	92	I12-003610	\$ 54.84
2221-61-613-43320	217744	BRODART COMPANY	92	I12-003611	\$ 81.90
2221-61-613-43320	217744	BRODART COMPANY	92	I12-003612	\$ 54.98
2221-61-613-43320	217744	BRODART COMPANY	92	I12-003613	\$ 33.67
2221-61-613-43320	217744	BRODART COMPANY	92	I12-003614	\$ 78.10
2221-61-613-43320	217744	BRODART COMPANY	92	I12-003615	\$ 54.79
2221-61-613-43320	217744	BRODART COMPANY	92	I12-003616	\$ 65.71
2221-61-613-43590	217883	SHORTGRASS WEB DEVELOPMENT	13638	I12-003596	\$ 1,950.00

				Fund(2221) Total	\$4,920.27
6070-31-521-43930	217583	CENTRAL LOCK & KEY PLUS SAFE INC	3805	I12-003193	\$ 156.00
6070-31-521-43412	217585	CENTURYLINK - QWEST CORPORATION	81	I12-002893	\$ 43.12
6070-31-521-43410	217585	CENTURYLINK - QWEST CORPORATION	81	I12-002894	\$ 157.23
6070-31-521-43630	217597	DAVIS BUSINESS MACHINES	293	I12-002887	\$ 43.88
6070-31-521-43630	217657	NATIONAL LAUNDRY	388	I12-003131	\$ 42.47
6070-31-521-42190	217669	PICKWICK'S OFFICE WORKS INC	367	I12-002885	\$ 43.95
6070-31-521-42190	217669	PICKWICK'S OFFICE WORKS INC	367	I12-003031	\$ 13.43
6070-31-521-42190	217669	PICKWICK'S OFFICE WORKS INC	367	I12-003032	\$ 33.98
6070-31-521-42190	217669	PICKWICK'S OFFICE WORKS INC	367	I12-003194	\$ 19.72
6070-31-521-42190	217669	PICKWICK'S OFFICE WORKS INC	367	I12-003196	\$ 8.28
6070-31-521-43415	217706	VERIZON WIRELESS	10858	I12-003191	\$ 357.16
6070-31-521-42190	217717	ACE HARDWARE	4876	I12-003273	\$ 27.44
6070-31-521-43630	217732	BIG SKY FIRE/AFFIRMED MEDICAL	2129	I12-003579	\$ 10.59
6070-31-521-42190	217768	DAY-TIMERS INC	8361	I12-003321	\$ 147.45
6070-31-521-43630	217846	NATIONAL LAUNDRY	388	I12-003517	\$ 5.50

City of Great Falls

Check Details Report (Date: 09/14/2011)

Account#	Check#	VendorName	Vendor#	Invoice#	Amount
6070-31-521-42190	217860	PICKWICK'S OFFICE WORKS INC	367	I12-003319	\$ 51.53
6070-31-521-42190	217860	PICKWICK'S OFFICE WORKS INC	367	I12-003398	\$ 27.00
6070-31-521-49310	217901	TILLERAAS LANDSCAPE NURSERY	3355	I12-003238	\$ 1,360.00

5410-16-513-49410	217575	BISON MOTOR CO INC	42	I12-002904	Fund(6070) Total \$2,548.73 \$ 27,432.22
5410-31-584-43410	217585	CENTURYLINK - QWEST CORPORATION	81	I12-003024	\$ 50.81
5410-31-585-43410	217585	CENTURYLINK - QWEST CORPORATION	81	I12-003024	\$ 50.81
5410-31-585-43560	217587	CHEMNET CONSORTIUM INC (THE)	11998	I12-002942	\$ 198.00
5410-31-588-43560	217587	CHEMNET CONSORTIUM INC (THE)	11998	I12-002942	\$ 49.50
5410-31-584-42390	217588	COLUMBIA PAINT & COATINGS	50	I12-003201	\$ 324.84
5410-31-584-43630	217657	NATIONAL LAUNDRY	388	I12-003126	\$ 10.74
5410-31-585-43630	217657	NATIONAL LAUNDRY	388	I12-003126	\$ 10.74
5410-31-588-43420	217660	NORTHWESTERN ENERGY	82	I12-003079	\$ 113.79
5410-31-584-42190	217669	PICKWICK'S OFFICE WORKS INC	367	I12-003187	\$ 5.85
5410-31-585-42190	217669	PICKWICK'S OFFICE WORKS INC	367	I12-003187	\$ 5.86
5410-31-584-43415	217706	VERIZON WIRELESS	10858	I12-003186	\$ 44.82
5410-31-585-43415	217706	VERIZON WIRELESS	10858	I12-003186	\$ 44.82
5410-31-588-43415	217706	VERIZON WIRELESS	10858	I12-003186	\$ 9.96
5410-31-584-43415	217706	VERIZON WIRELESS	10858	I12-003191	\$ 18.88
5410-31-585-43415	217706	VERIZON WIRELESS	10858	I12-003191	\$ 18.88
5410-31-588-43415	217706	VERIZON WIRELESS	10858	I12-003191	\$ 30.51
5410-31-584-42290	217732	BIG SKY FIRE/AFFIRMED MEDICAL	2129	I12-003495	\$ 17.74
5410-31-585-42290	217732	BIG SKY FIRE/AFFIRMED MEDICAL	2129	I12-003495	\$ 17.74
5410-31-584-42290	217732	BIG SKY FIRE/AFFIRMED MEDICAL	2129	I12-003579	\$ 5.30
5410-31-585-42290	217732	BIG SKY FIRE/AFFIRMED MEDICAL	2129	I12-003579	\$ 5.29
5410-31-585-43410	217771	DEX MEDIA WEST INC	11442	I12-003212	\$ 84.16
5410-31-588-43410	217771	DEX MEDIA WEST INC	11442	I12-003212	\$ 18.70
5410-31-584-43410	217771	DEX MEDIA WEST INC	11442	I12-003212	\$ 84.16
5410-31-588-43430	217784	ENERGY WEST RESOURCES INC	83	I11-007335	\$ 100.92
5410-31-584-43445	217834	MONTANA WASTE SYSTEMS INC	8467	I12-003290	\$ 25,705.40

City of Great Falls

Check Details Report (Date: 09/14/2011)

Account#	Check#	VendorName	Vendor#	Invoice#	Amount
5410-31-585-43445	217834	MONTANA WASTE SYSTEMS INC	8467	I12-003290	\$ 50,135.45
5410-31-588-43445	217834	MONTANA WASTE SYSTEMS INC	8467	I12-003290	\$ 8,458.70
5410-31-584-42190	217860	PICKWICK'S OFFICE WORKS INC	367	I12-003449	\$ 12.66
5410-31-585-42190	217860	PICKWICK'S OFFICE WORKS INC	367	I12-003449	\$ 12.67

Fund(5410) Total					\$113,079.92
6075-31-511-43420	217660	NORTHWESTERN ENERGY	82	I12-002877	\$ 9.69
6075-31-511-43420	217660	NORTHWESTERN ENERGY	82	I12-003079	\$ 792.56
6075-31-511-43415	217706	VERIZON WIRELESS	10858	I12-003191	\$ 76.09
6075-31-511-43430	217784	ENERGY WEST RESOURCES INC	83	I11-007335	\$ 338.99

Fund(6075) Total					\$1,217.33
5720-21-313-43790	217649	MONTANA LAW ENFORCEMENT ACADEMY	1972	I12-002849	\$ 200.00
5720-21-313-43790	217649	MONTANA LAW ENFORCEMENT ACADEMY	1972	I12-002851	\$ 200.00
5720-21-313-43790	217649	MONTANA LAW ENFORCEMENT ACADEMY	1972	I12-002852	\$ 444.00
5720-21-313-43420	217660	NORTHWESTERN ENERGY	82	I12-003079	\$ 240.67
5720-21-313-43790	217675	RATLIFF ANGELLA	13490	I12-003206	\$ 43.01
5720-21-313-43417	217714	3 RIVERS TELEPHONE COOPERATIVE INC	1343	I12-003277	\$ 93.74
5720-21-313-43417	217714	3 RIVERS TELEPHONE COOPERATIVE INC	1343	I12-003278	\$ 93.74
5720-21-313-43417	217714	3 RIVERS TELEPHONE COOPERATIVE INC	1343	I12-003279	\$ 105.00
5720-21-313-43417	217714	3 RIVERS TELEPHONE COOPERATIVE INC	1343	I12-003280	\$ 343.95
5720-21-313-42190	217747	CALL ONE INC	11726	I12-003265	\$ 309.00
5720-21-313-43630	217767	DAVIS BUSINESS MACHINES	293	I12-002845	\$ 45.55
5720-21-313-43430	217784	ENERGY WEST RESOURCES INC	83	I11-007335	\$ 29.59
5720-21-313-43415	217910	VERIZON WIRELESS	10858	I12-003272	\$ 33.01

Fund(5720) Total					\$2,181.26
2890-24-411-42260	217554	ACE HARDWARE	4876	I12-003093	\$ 27.99
2890-24-411-43790	217596	DAVIDSON TRAVEL INC	4813	I12-002937	\$ 515.80
2890-24-411-43790	217596	DAVIDSON TRAVEL INC	4813	I12-002943	\$ 602.80
2890-24-411-43790	217596	DAVIDSON TRAVEL INC	4813	I12-002945	\$ 1,667.40

City of Great Falls

Check Details Report (Date: 09/14/2011)

Account#	Check#	VendorName	Vendor#	Invoice#	Amount
2890-24-411-43590	217770	DETAILED CONSTRUCTION CO	13556	I12-003297	\$ 29,165.40
2890-24-411-43590	217840	MT DEPT OF REVENUE 1% WITHHOLDING	136	I12-003298	\$ 294.60

5725-71-725-43690	217622	GREENUP LAWN AND SPRINKLERS INC	11268	Fund(2890) Total I12-002939	\$32,273.99 \$ 67.75
5725-71-725-43420	217660	NORTHWESTERN ENERGY	82	I12-002877	\$ 375.33
5725-71-725-43420	217660	NORTHWESTERN ENERGY	82	I12-003079	\$ 439.72
5725-71-725-42290	217672	PROBUILD	25	I12-003157	\$ 17.97
5725-71-725-42290	217764	CONSOLIDATED ELECTRICAL DIST INC	52	I12-003377	\$ 222.56
5725-71-725-42290	217765	CRESCENT ELECTRIC SUPPLY CO	405	I12-003375	\$ 193.44
5725-71-725-43690	217778	DUNCAN PARKING TECHNOLOGIES INC	7193	I12-003372	\$ 6.75
5725-71-725-42290	217830	MASTERCARD PROCESSING CENTER	8270	I12-003414	\$ 868.95
5725-71-725-42190	217864	PRINTING CENTER	117	I12-003365	\$ 34.32

2940-71-742-43590	217556	ALR CONTRACTING LLC	13608	Fund(5725) Total I12-003171	\$2,226.79 \$ 4,250.00
2940-71-742-43590	217569	BEST VALUE PLUMBING & ROOTER SERV	585	I12-003188	\$ 446.85
2940-71-742-43590	217574	BILL LEWIS CONTRACTOR	13621	I12-003170	\$ 4,695.10
2940-71-742-43590	217691	T & B CONSTRUCTION INC	13619	I12-003010	\$ 4,166.00
2940-71-741-43415	217706	VERIZON WIRELESS	10858	I12-002928	\$ 22.61
2940-71-742-47330	217715	A T KLEMENS INC	84	I12-003232	\$ 302.40
2940-71-742-43590	217735	BILL LEWIS CONTRACTOR	13621	I12-003381	\$ 1,200.00
2940-71-742-43590	217753	CASCADE COUNTY CLERK & RECORDER	130	I12-003440	\$ 21.00
2940-71-742-47330	217792	FUSION ARCHITECTURE & DESIGN PC	12988	I12-003233	\$ 400.00
2940-71-742-49310	217802	GREGOIRE CONSTRUCTION	4917	I12-003242	\$ 4,368.53
2940-71-742-43590	217821	JTR CONSTRUCTION	13592	I12-003380	\$ 4,000.00
2940-71-741-42190	217830	MASTERCARD PROCESSING CENTER	8270	I12-003414	\$ 234.99
2940-71-742-49310	217840	MT DEPT OF REVENUE 1% WITHHOLDING	136	I12-003245	\$ 44.13

5730-64-662-43590	217555	ALARM SERVICE INC	177	Fund(2940) Total I12-003137	\$24,151.61 \$ 50.00
5730-64-662-43640	217591	CONSOLIDATED ELECTRICAL DIST INC	52	I12-002891	\$ 86.55
5730-64-662-42350	217593	CRESCENT ELECTRIC SUPPLY CO	405	I12-002889	\$ 30.23

City of Great Falls

Check Details Report (Date: 09/14/2011)

Account#	Check#	VendorName	Vendor#	Invoice#	Amount
5730-64-662-43590	217640	MASCO JANITORIAL SUPPLY	198	I12-002890	\$ 1,050.00
5730-64-662-43420	217660	NORTHWESTERN ENERGY	82	I12-003079	\$ 790.89
5730-64-662-43415	217706	VERIZON WIRELESS	10858	I12-003167	\$ 45.24
5730-64-662-43620	217764	CONSOLIDATED ELECTRICAL DIST INC	52	I12-003601	\$ 13.90
5730-64-662-49220	217764	CONSOLIDATED ELECTRICAL DIST INC	52	I12-003602	\$ 5.36
5730-64-662-42350	217765	CRESCENT ELECTRIC SUPPLY CO	405	I12-003307	\$ 86.01
5730-64-662-43430	217784	ENERGY WEST RESOURCES INC	83	I11-007335	\$ 301.08
5730-64-662-43590	217797	GETTEN CHAD A	12364	I12-003301	\$ 268.00
5730-64-662-42350	217798	GLACIER STATE ELECTRIC SUPPLY	67	I12-003603	\$ 23.00
5730-64-662-43590	217799	GRAHAM JEFFREY	12544	I12-003300	\$ 268.00
5730-64-662-42350	217829	MASCO JANITORIAL SUPPLY	198	I12-003304	\$ 12.12
5730-64-662-42230	217846	NATIONAL LAUNDRY	388	I12-003448	\$ 124.75
5730-64-662-43590	217863	PRESTON MICHELLE	9924	I12-003302	\$ 330.00
5730-64-662-42290	217877	RYANS CASH & CARRY	191	I12-003303	\$ 20.94
5730-64-662-42290	217880	SAMS CLUB	4909	I12-003305	\$ 154.73
5730-64-662-43590	217897	TEMP TRACK LLC	3182	I12-003532	\$ 378.80
5730-64-662-43590	217897	TEMP TRACK LLC	3182	I12-003533	\$ 378.80
5730-64-662-43590	217912	WESTERN OFFICE EQUIPMENT	74	I12-003306	\$ 37.50

6055-14-181-43790	217643	Michael Dahlem	13388	Fund(5730) Total I12-003175	\$4,455.90 \$ 100.00

					Fund(6055) Total\$100.00
7910-00-000-20902	0	1ST INTERSTATE BANK	5320	I12-003060	\$ 94,880.54
7910-00-000-20905	0	1ST INTERSTATE BANK	5320	I12-003061	\$ 95,815.87
7910-00-000-20947	0	CITY OF GREAT FALLS HEALTH	5319	I12-003059	\$ 238,822.50
7910-00-000-10100	0	CITY OF GREAT FALLS HEALTH	5319	I12-003059	\$ -238,822.50
7910-00-000-20908	0	FIREFIGHTER RETIREMENT SYS	4271	I12-003055	\$ 44,446.78
7910-00-000-20944	0	ICMA RETIREMENT TRUST-457	4245	I12-003040	\$ 11,110.55
7910-00-000-20945	0	NATIONWIDE RETIREMENT SOLUTIONS	13276	I12-003069	\$ 3,503.63
7910-00-000-20907	0	PUBLIC EMPLOYEE RETIREMENT SYS	4273	I12-003057	\$ 101,783.11
7910-00-000-20906	0	STATEWIDE POLICE RESERVE FUND	4272	I12-003056	\$ 53,656.23

City of Great Falls

Check Details Report (Date: 09/14/2011)

Account#	Check#	VendorName	Vendor#	Invoice#	Amount
7910-00-000-20915	217530	8TH DISTRICT ELECTRICAL	4256	I12-002238	\$ 816.08
7910-00-000-20915	217530	8TH DISTRICT ELECTRICAL	4256	I12-003049	\$ 804.27
7910-00-000-20953	217531	AFLAC	6735	I12-003062	\$ 5,012.09
7910-00-000-20955	217531	AFLAC	6735	I12-003063	\$ 5,640.10
7910-00-000-20958	217531	AFLAC	6735	I12-003064	\$ 426.58
7910-00-000-20959	217531	AFLAC	6735	I12-003065	\$ 1,257.17
7910-00-000-20941	217532	IAFF LOCAL #8 INT'L ASSOC FIRE FIG	4299	I12-003058	\$ 2,100.00
7910-00-000-20935	217533	IAM & AW LOCAL #88	4249	I12-003043	\$ 185.00
7910-00-000-20920	217534	IAM NATIONAL PENSION FUND	9514	I12-002258	\$ 668.80
7910-00-000-20920	217534	IAM NATIONAL PENSION FUND	9514	I12-003066	\$ 729.60
7910-00-000-20937	217535	IBEW LOCAL 233	4251	I12-002234	\$ 345.33
7910-00-000-20937	217535	IBEW LOCAL 233	4251	I12-003045	\$ 170.94
7910-00-000-20917	217536	IBPAT PENSION FUND	4269	I12-002244	\$ 228.00
7910-00-000-20917	217536	IBPAT PENSION FUND	4269	I12-003054	\$ 230.40
7910-00-000-20938	217537	INT'L BROTHERHOOD TEAMSTERS LOCAL 2	4259	I12-003052	\$ 25.00
7910-00-000-20950	217538	LINCOLN NATIONAL LIFE INS CO	11479	I12-002259	\$ 759.29
7910-00-000-20950	217538	LINCOLN NATIONAL LIFE INS CO	11479	I12-003067	\$ 1,663.62
7910-00-000-20912	217540	LIUNA NATIONAL (INDUSTRIAL)	4248	I12-002232	\$ 9,730.60
7910-00-000-20912	217540	LIUNA NATIONAL (INDUSTRIAL)	4248	I12-003042	\$ 10,717.30
7910-00-000-20914	217541	MONTANA CHAPTER NECA INC	4255	I12-002237	\$ 320.64
7910-00-000-20914	217541	MONTANA CHAPTER NECA INC	4255	I12-003048	\$ 341.90
7910-00-000-20916	217542	MONTANA OE - CI TRUST FUND	4257	I12-002239	\$ 8,813.38
7910-00-000-20916	217542	MONTANA OE - CI TRUST FUND	4257	I12-003050	\$ 9,521.44
7910-00-000-20949	217543	MONTANA POLICE PROTECTIVE ASSO	4258	I12-003051	\$ 2,733.75
7910-00-000-20904	217545	MT STATE TREASURER PAYROLL	4244	I12-003039	\$ 40,862.00
7910-00-000-20934	217546	PAINTERS LOCAL 260	4247	I12-002231	\$ 69.80
7910-00-000-20932	217547	PLUMBERS & FITTERS LOCAL 41	4237	I12-002224	\$ 584.78
7910-00-000-20932	217547	PLUMBERS & FITTERS LOCAL 41	4237	I12-003035	\$ 402.06
7910-00-000-20910	217548	PPNPF PLUMBERS & PIPEFITTERS	4239	I12-002226	\$ 2,107.00

City of Great Falls

Check Details Report (Date: 09/14/2011)

Account#	Check#	VendorName	Vendor#	Invoice#	Amount
7910-00-000-20910	217548	PPNPF PLUMBERS & PIPEFITTERS	4239	I12-003037	\$ 2,016.00
7910-00-000-20922	217549	UNITED FUND	4264	I12-003053	\$ 464.44
7910-00-000-20913	217550	WESTERN CONF OF TEAMSTERS	4254	I12-002236	\$ 7,517.52
7910-00-000-20913	217550	WESTERN CONF OF TEAMSTERS	4254	I12-003047	\$ 8,165.03
7910-00-000-20933	217551	LIUNA LOCAL 1686	4242	I12-003038	\$ 396.00

2412-31-536-42390	217591	CONSOLIDATED ELECTRICAL DIST INC	52	I12-002803	\$ 5,900.00
					Fund(7910) Total\$531,022.62

6052-00-000-10100	0	CITY OF GREAT FALLS HEALTH	5319	I12-003059	\$ 238,822.50
					Fund(2412) Total\$5,900.00
6052-15-267-34198	0	CITY OF GREAT FALLS HEALTH	5319	I12-003059	\$ -238,822.50
6052-15-267-43590	217647	MILLIMAN INC	13465	I12-002882	\$ 2,500.00
6052-15-267-45130	217873	REYNOLDS ALEECE	13519	I12-003476	\$ 95.32

6050-15-266-42190	217669	PICKWICK'S OFFICE WORKS INC	367	I12-002909	\$ 1.59
					Fund(6052) Total\$2,595.32
6050-15-266-45110	217803	HAAS & WILKERSON HOLDINGS INC	2909	I12-003267	\$ 103.00
6050-15-266-45125	217842	MT MUNICIPAL INTERLOCAL AUTHORITY W	4238	I12-003426	\$ 8,784.41

2945-71-751-43210	217753	CASCADE COUNTY CLERK & RECORDER	130	I12-003440	\$ 7.00
					Fund(6050) Total\$8,889.00

5315-10-031-46310	0	U S BANK NATIONAL ASSOCIATION	13539	I12-003397	\$ 300.00
					Fund(2945) Total\$7.00
5315-31-575-42360	217611	FERGUSON ENTERPRISES INC #3201	8915	I12-002800	\$ 1,820.00
5315-31-575-49310	217840	MT DEPT OF REVENUE 1% WITHHOLDING	136	I12-003523	\$ 13.13
5315-31-575-49310	217859	PHILLIPS CONSTRUCTION	9122	I12-003521	\$ 1,300.30
5315-31-575-49325	217899	THOMAS DEAN & HOSKINS INC	119	I12-003571	\$ 87,390.00

2510-64-634-42220	217613	FLEET SUPPLY COMPANY	64	I12-003174	\$ 26.95
					Fund(5315) Total\$90,823.43
2510-64-634-42220	217613	FLEET SUPPLY COMPANY	64	I12-003178	\$ 1.99
2510-64-635-42290	217638	LAWSON PRODUCTS INC	6589	I12-003172	\$ 39.62
2510-64-634-42290	217638	LAWSON PRODUCTS INC	6589	I12-003172	\$ 39.61
2510-64-634-43590	217646	MIDWAY RENTAL AND POWER	13370	I12-002892	\$ 2,400.00

City of Great Falls

Check Details Report (Date: 09/14/2011)

Account#	Check#	VendorName	Vendor#	Invoice#	Amount
EQUIPMENT I					
2510-64-635-43415	217706	VERIZON WIRELESS	10858	I12-003163	\$ 60.92
2510-64-634-43415	217706	VERIZON WIRELESS	10858	I12-003163	\$ 60.91
2510-64-635-43590	217777	DR LAWN LANDSCAPE SERVICE	13635	I12-003213	\$ 20,325.00
2510-64-635-43445	217834	MONTANA WASTE SYSTEMS INC	8467	I12-003290	\$ 100.12
2510-64-634-42390	217862	POWER PRO EQUIPMENT CO	8197	I12-003402	\$ 74.90

6030-15-212-43412	217585	CENTURYLINK - QWEST CORPORATION	81	Fund(2510) Total I12-001958	\$23,130.02 \$ 1,154.25
6030-15-213-43350	217589	COMPUTER SOFTWARE ASSOCIATES INC	12645	I12-003025	\$ 406.00
6030-15-214-42120	217625	HEWLETT-PACKARD COMPANY	5771	I12-003078	\$ 15,181.28
6030-15-214-42120	217641	MASTERCARD PROCESSING CENTER	8270	I12-003073	\$ 199.99
6030-15-212-43690	217641	MASTERCARD PROCESSING CENTER	8270	I12-003074	\$ 210.24
6030-15-214-42120	217641	MASTERCARD PROCESSING CENTER	8270	I12-003075	\$ 149.98
6030-15-213-42190	217669	PICKWICK'S OFFICE WORKS INC	367	I12-003077	\$ 5.29
6030-15-212-43415	217706	VERIZON WIRELESS	10858	I12-003076	\$ 118.76
6030-15-213-43415	217706	VERIZON WIRELESS	10858	I12-003076	\$ 19.40
6030-15-214-42120	217758	CDW GOVERNMENT INC	8296	I12-003353	\$ 874.30
6030-15-212-43630	217795	GEOGRAPHIC TECHNOLOGIES GROUP INC	13452	I12-003355	\$ 2,000.00
6030-15-212-42190	217860	PICKWICK'S OFFICE WORKS INC	367	I12-003357	\$ 42.73
6030-15-212-43630	217866	PRODATA COMPUTER SERVICES INC	7744	I12-003349	\$ 510.00

1000-64-633-42290	217552	2M COMPANY INC (RD RR9)	195	Fund(6030) Total I12-002899	\$20,872.22 \$ 1,500.00
1000-24-411-43620	217553	A T KLEMENS INC	84	I12-002961	\$ 755.82
1000-24-411-43620	217553	A T KLEMENS INC	84	I12-002962	\$ 707.46
1000-64-633-42290	217554	ACE HARDWARE	4876	I12-002528	\$ 79.98
1000-24-411-42230	217554	ACE HARDWARE	4876	I12-003097	\$ 4.27
1000-24-411-42230	217554	ACE HARDWARE	4876	I12-003098	\$ 13.99
1000-24-411-43620	217554	ACE HARDWARE	4876	I12-003100	\$ 24.23
1000-64-633-43590	217555	ALARM SERVICE INC	177	I12-003134	\$ 50.00
1000-00-000-21421	217558	ANIMAL MEDICAL CLINIC	506	I12-002911	\$ 45.00

City of Great Falls

Check Details Report (Date: 09/14/2011)

Account#	Check#	VendorName	Vendor#	Invoice#	Amount
1000-00-000-21421	217559	Ann Lacock	12707	I12-003016	\$ 15.00
1000-14-141-34410	217559	Ann Lacock	12707	I12-003016	\$ 55.00
1000-00-000-21421	217562	ASSOCIATED VETERINARY SERVICES	162	I12-002923	\$ 15.00
1000-21-312-43560	217565	BENEFIS HEALTH SYSTEM (TESTING)	6751	I12-002844	\$ 300.00
1000-14-141-32330	217567	BEST FRIENDS ANIMAL HOSPITAL PC	9117	I12-002924	\$ 36.00
1000-00-000-21421	217568	BEST FRIENDS ANIMAL HOSPITAL PC	9117	I12-002925	\$ 60.00
1000-64-633-42290	217570	BIG R STORES (CSWW INC)	40	I12-002901	\$ 19.98
1000-24-411-42330	217570	BIG R STORES (CSWW INC)	40	I12-002970	\$ 109.96
1000-00-000-21421	217571	BIG SKY ANIMAL MEDICAL CENTER	12915	I12-002926	\$ 120.00
1000-24-411-43640	217572	BIG SKY FIRE/AFFIRMED MEDICAL	2129	I12-002957	\$ 455.00
1000-24-411-43640	217572	BIG SKY FIRE/AFFIRMED MEDICAL	2129	I12-002958	\$ 450.00
1000-24-412-42190	217576	BLENDS COPY SHOP INC	43	I12-002956	\$ 103.15
1000-24-411-42220	217577	BOUND TREE MEDICAL LLC	10455	I12-003091	\$ 88.49
1000-64-633-42290	217579	CASCADE COUNTY WEED CONTROL DIST	12332	I12-003014	\$ 47.25
1000-00-000-21421	217584	CENTRAL WEST ANIMAL CLINIC	1599	I12-002927	\$ 15.00
1000-15-281-43410	217585	CENTURYLINK - QWEST CORPORATION	81	I12-002917	\$ 49.68
1000-64-622-43410	217585	CENTURYLINK - QWEST CORPORATION	81	I12-003129	\$ 148.57
1000-64-621-43410	217585	CENTURYLINK - QWEST CORPORATION	81	I12-003144	\$ 221.70
1000-00-000-21400	217586	CHANDLER COMMUNICATIONS	3702	I12-002733	\$ 694.00
1000-00-000-21422	217592	COUNTRY HAVEN VETERINARY CLINIC PC	12966	I12-002973	\$ 420.00
1000-00-000-21421	217592	COUNTRY HAVEN VETERINARY CLINIC PC	12966	I12-002974	\$ 60.00
1000-00-000-21421	217592	COUNTRY HAVEN VETERINARY CLINIC PC	12966	I12-002985	\$ 15.00
1000-00-000-12400	217595	DARBY, DEVIN	13626	I12-003208	\$ 757.20
1000-15-283-43520	217602	E. LEE LEVEQUE	3702	I12-002912	\$ 230.00
1000-64-633-42290	217606	FAGENSTROM CO (THE)	731	I12-002898	\$ 127.50
1000-64-622-42520	217607	FARCOUNTRY PRESS	9962	I12-003132	\$ 53.96
1000-21-311-43110	217609	FEDERAL EXPRESS CORPORATION	127	I12-002860	\$ 91.76
1000-00-000-21421	217628	INDIAN HAMMER VETERINARY SVC	8699	I12-002976	\$ 15.00

City of Great Falls

Check Details Report (Date: 09/14/2011)

Account#	Check#	VendorName	Vendor#	Invoice#	Amount
1000-15-283-43520	217630	JAMES DONAHUE	3702	I12-002910	\$ 250.00
1000-15-283-43520	217631	JAMES F GARDNER	3702	I12-002906	\$ 100.00
1000-00-000-21422	217632	James Weber	12707	I12-003140	\$ 200.00
1000-14-141-34416	217633	Jennifer Thomas	12707	I12-003127	\$ 205.00
1000-64-633-42330	217634	JOHNSON DISTRIBUTING	8	I12-002618	\$ 566.00
1000-21-311-42290	217639	LEHRKINDS INC	6173	I12-002847	\$ 284.05
1000-64-633-42230	217640	MASCO JANITORIAL SUPPLY	198	I12-002903	\$ 789.15
1000-21-325-43790	217641	MASTERCARD PROCESSING CENTER	8270	I12-002857	\$ 46.55
1000-21-325-43790	217641	MASTERCARD PROCESSING CENTER	8270	I12-002857	\$ 23.10
1000-21-391-43590	217641	MASTERCARD PROCESSING CENTER	8270	I12-002857	\$ 1,329.57
1000-64-621-42190	217641	MASTERCARD PROCESSING CENTER	8270	I12-002949	\$ 19.96
1000-24-412-43790	217641	MASTERCARD PROCESSING CENTER	8270	I12-003114	\$ 158.00
1000-24-412-42140	217641	MASTERCARD PROCESSING CENTER	8270	I12-003114	\$ 262.50
1000-24-411-43620	217641	MASTERCARD PROCESSING CENTER	8270	I12-003114	\$ 289.88
1000-24-411-42190	217641	MASTERCARD PROCESSING CENTER	8270	I12-003114	\$ 15.26
1000-24-411-43210	217641	MASTERCARD PROCESSING CENTER	8270	I12-003114	\$ 151.48
1000-64-622-42520	217648	MONTANA FLAG AND POLE CO	12702	I12-002704	\$ 100.00
1000-15-281-43790	217650	MONTANA SUPREME COURT	2119	I12-003198	\$ 250.00
1000-15-283-43790	217650	MONTANA SUPREME COURT	2119	I12-003199	\$ 300.00
1000-14-173-43520	217651	MOULTON BELLINGHAM PC	13512	I12-002457	\$ 19,416.05
1000-21-323-43420	217660	NORTHWESTERN ENERGY	82	I12-002877	\$ 8.46
1000-21-341-43420	217660	NORTHWESTERN ENERGY	82	I12-002877	\$ 204.81
1000-64-622-43420	217660	NORTHWESTERN ENERGY	82	I12-002877	\$ 80.40
1000-64-633-43420	217660	NORTHWESTERN ENERGY	82	I12-002877	\$ 509.55
1000-21-311-43420	217660	NORTHWESTERN ENERGY	82	I12-003079	\$ 962.68
1000-24-411-43420	217660	NORTHWESTERN ENERGY	82	I12-003079	\$ 708.85
1000-64-621-43420	217660	NORTHWESTERN ENERGY	82	I12-003079	\$ 319.30
1000-64-633-43420	217660	NORTHWESTERN ENERGY	82	I12-003079	\$ 74.37
1000-24-411-43630	217662	OFFICE CENTER INC (THE)	2499	I12-003090	\$ 52.50
1000-64-633-43710	217666	PARKER, PAISLEY	13569	I12-002523	\$ 75.48

City of Great Falls

Check Details Report (Date: 09/14/2011)

Account#	Check#	VendorName	Vendor#	Invoice#	Amount
1000-00-000-21422	217667	Paula Andersen	12707	I12-003125	\$ 200.00
1000-64-621-42190	217669	PICKWICK'S OFFICE WORKS INC	367	I12-002513	\$ 8.80
1000-15-281-42190	217669	PICKWICK'S OFFICE WORKS INC	367	I12-002913	\$ 254.18
1000-24-411-42110	217669	PICKWICK'S OFFICE WORKS INC	367	I12-002954	\$ 52.52
1000-15-281-42190	217669	PICKWICK'S OFFICE WORKS INC	367	I12-002987	\$ 4.19
1000-64-633-42330	217670	POWER PRO EQUIPMENT CO	8197	I12-002900	\$ 27.40
1000-64-633-42330	217670	POWER PRO EQUIPMENT CO	8197	I12-002902	\$ 15.50
1000-64-633-42290	217680	SELSTAD'S SOD FARM	9248	I12-002633	\$ 27.00
1000-64-633-42290	217680	SELSTAD'S SOD FARM	9248	I12-002634	\$ -24.00
1000-15-283-43520	217687	STATE LAW LIBRARY OF MONTANA	4295	I12-002919	\$ 625.00
1000-15-283-43520	217690	SUTTON MEGHAN	11443	I12-002989	\$ 200.00
1000-24-412-42260	217701	TOOL BOX INC	2886	I12-002967	\$ 97.20
1000-64-633-42290	217703	UNITED MATERIALS OF GREAT FALLS INC	121	I12-002905	\$ 62.43
1000-64-633-42290	217703	UNITED MATERIALS OF GREAT FALLS INC	121	I12-002905	\$ 64.63
1000-64-633-42290	217703	UNITED MATERIALS OF GREAT FALLS INC	121	I12-002905	\$ -6.37
1000-24-411-43415	217706	VERIZON WIRELESS	10858	I12-002948	\$ 23.28
1000-24-412-43415	217706	VERIZON WIRELESS	10858	I12-002948	\$ 23.28
1000-24-461-43415	217706	VERIZON WIRELESS	10858	I12-002948	\$ 170.64
1000-24-411-43415	217706	VERIZON WIRELESS	10858	I12-002952	\$ 255.20
1000-24-412-43415	217706	VERIZON WIRELESS	10858	I12-002952	\$ 93.57
1000-24-461-43415	217706	VERIZON WIRELESS	10858	I12-002952	\$ 82.28
1000-64-633-43415	217706	VERIZON WIRELESS	10858	I12-003149	\$ 125.21
1000-64-633-43415	217706	VERIZON WIRELESS	10858	I12-003152	\$ 125.21
1000-64-633-43415	217706	VERIZON WIRELESS	10858	I12-003160	\$ 125.21
1000-64-621-43415	217706	VERIZON WIRELESS	10858	I12-003167	\$ 252.94
1000-00-000-21421	217708	Waylon Blackwell	12707	I12-003122	\$ 15.00
1000-00-000-21422	217708	Waylon Blackwell	12707	I12-003122	\$ 100.00
1000-14-141-32330	217709	WESTSIDE ANIMAL CLINIC	3378	I12-002978	\$ 10.00
1000-00-000-21421	217710	WESTSIDE ANIMAL CLINIC	3378	I12-002984	\$ 30.00
1000-24-411-42220	217713	ZOLL MEDICAL CORP	10314	I12-002959	\$ 1,080.00

City of Great Falls

Check Details Report (Date: 09/14/2011)

Account#	Check#	VendorName	Vendor#	Invoice#	Amount
1000-24-411-42220	217713	ZOLL MEDICAL CORP	10314	I12-002960	\$ 1,756.00
1000-14-141-42290	217717	ACE HARDWARE	4876	I12-003281	\$ 49.99
1000-14-141-42290	217717	ACE HARDWARE	4876	I12-003283	\$ 107.87
1000-14-141-42290	217717	ACE HARDWARE	4876	I12-003284	\$ 102.97
1000-14-141-42290	217717	ACE HARDWARE	4876	I12-003285	\$ 115.03
1000-21-391-42120	217718	ALCOPRO INC	5133	I12-003189	\$ 3,534.00
1000-14-141-43590	217721	ANIMAL MEDICAL CLINIC	506	I12-003466	\$ 150.00
1000-14-141-43590	217721	ANIMAL MEDICAL CLINIC	506	I12-003469	\$ 60.00
1000-14-141-43590	217721	ANIMAL MEDICAL CLINIC	506	I12-003470	\$ 124.00
1000-14-141-43590	217721	ANIMAL MEDICAL CLINIC	506	I12-003472	\$ 35.00
1000-14-141-43590	217721	ANIMAL MEDICAL CLINIC	506	I12-003473	\$ 105.00
1000-14-141-43590	217721	ANIMAL MEDICAL CLINIC	506	I12-003474	\$ 25.00
1000-14-141-43590	217721	ANIMAL MEDICAL CLINIC	506	I12-003475	\$ 75.00
1000-14-141-43590	217721	ANIMAL MEDICAL CLINIC	506	I12-003477	\$ 60.00
1000-14-141-43590	217721	ANIMAL MEDICAL CLINIC	506	I12-003478	\$ 75.00
1000-14-141-43590	217721	ANIMAL MEDICAL CLINIC	506	I12-003479	\$ 25.00
1000-14-141-43590	217721	ANIMAL MEDICAL CLINIC	506	I12-003480	\$ 75.00
1000-21-322-43350	217722	ANIMAL MEDICAL CLINIC	506	I12-003313	\$ 57.00
1000-00-000-21421	217723	Apex Animal Hospital	12707	I12-003260	\$ 15.00
1000-00-000-21422	217724	ASSOCIATED VETERINARY SERVICES	162	I12-003263	\$ 109.00
1000-00-000-21421	217725	Aubrei Harris	12707	I12-003246	\$ 15.00
1000-64-622-42520	217727	BELTER PAT	12408	I12-003580	\$ 57.00
1000-21-312-43560	217728	BENEFIS HEALTH SYSTEM (TESTING)	6751	I12-003276	\$ 300.00
1000-21-327-42290	217734	BIG SKY IMPRINTS	5262	I12-003312	\$ 273.00
1000-00-000-21421	217737	Bobbi Porro	12707	I12-003247	\$ 15.00
1000-14-111-42290	217738	BOYD COFFEE COMPANY	3264	I12-003518	\$ 156.76
1000-00-000-21422	217739	Brandi Monks	12707	I12-003258	\$ 200.00
1000-00-000-12400	217741	BREKKE CHRIS	13348	I12-003500	\$ 103.90
1000-00-000-12400	217742	BRINKMAN PAT	8060	I12-003207	\$ 1,207.40
1000-21-323-42250	217746	BVAC INC	12985	I12-003268	\$ 14,285.00

City of Great Falls

Check Details Report (Date: 09/14/2011)

Account#	Check#	VendorName	Vendor#	Invoice#	Amount
1000-00-000-12400	217749	CALVERT CHRIS	12013	I12-003514	\$ 435.96
1000-21-314-43640	217751	CAPITAL COMMUNICATIONS	13091	I12-003347	\$ 32.50
1000-14-141-43590	217752	CAREER QUEST	13466	I12-003362	\$ 278.80
1000-14-141-43590	217752	CAREER QUEST	13466	I12-003367	\$ 610.90
1000-14-141-43590	217752	CAREER QUEST	13466	I12-003373	\$ 3,089.35
1000-14-141-43590	217752	CAREER QUEST	13466	I12-003376	\$ 610.90
1000-14-141-43590	217752	CAREER QUEST	13466	I12-003378	\$ 2,117.65
1000-00-000-21461	217756	Casey Heavy Runner	12646	I12-003452	\$ 50.00
1000-00-000-21422	217757	Cassie Wilson	12707	I12-003256	\$ 200.00
1000-00-000-21421	217759	Charolette Stewart	12707	I12-003257	\$ 15.00
1000-00-000-21422	217759	Charolette Stewart	12707	I12-003257	\$ 200.00
1000-64-633-43710	217760	CHENOWETH, CARLY	13567	I12-003439	\$ 94.35
1000-00-000-12400	217766	DALKE LONNIE	11352	I12-003497	\$ 178.90
1000-21-311-43630	217767	DAVIS BUSINESS MACHINES	293	I12-002845	\$ 60.73
1000-21-312-43630	217767	DAVIS BUSINESS MACHINES	293	I12-002845	\$ 54.66
1000-21-314-43630	217767	DAVIS BUSINESS MACHINES	293	I12-002845	\$ 27.33
1000-21-315-43630	217767	DAVIS BUSINESS MACHINES	293	I12-002845	\$ 88.03
1000-21-324-43630	217767	DAVIS BUSINESS MACHINES	293	I12-002845	\$ 3.04
1000-21-325-43630	217767	DAVIS BUSINESS MACHINES	293	I12-002845	\$ 21.26
1000-21-326-43630	217767	DAVIS BUSINESS MACHINES	293	I12-002845	\$ 1.52
1000-21-342-43630	217767	DAVIS BUSINESS MACHINES	293	I12-002845	\$ 1.52
1000-21-311-42190	217767	DAVIS BUSINESS MACHINES	293	I12-003266	\$ 69.00
1000-00-000-21422	217769	Deb Bourgeois	12707	I12-003262	\$ 91.00
1000-00-000-12400	217775	DOYON GREGORY T	12958	I12-003538	\$ 1,152.30
1000-00-000-12400	217779	DUNLOP DAVID	5103	I12-003507	\$ 435.96
1000-15-283-43520	217780	E. LEE LEVEQUE	3702	I12-003625	\$ 130.00
1000-14-141-43590	217781	ECOLAB PEST ELIMINATION	4334	I12-003295	\$ 52.00
1000-00-000-21422	217782	Elizabeth Casselli	12707	I12-003249	\$ 200.00
1000-14-141-34415	217782	Elizabeth Casselli	12707	I12-003249	\$ -19.00
1000-21-311-43430	217784	ENERGY WEST RESOURCES INC	83	I11-007335	\$ 118.36

City of Great Falls

Check Details Report (Date: 09/14/2011)

Account#	Check#	VendorName	Vendor#	Invoice#	Amount
1000-21-341-43430	217784	ENERGY WEST RESOURCES INC	83	I11-007335	\$ 814.25
1000-24-411-43430	217784	ENERGY WEST RESOURCES INC	83	I11-007335	\$ 863.37
1000-64-621-43430	217784	ENERGY WEST RESOURCES INC	83	I11-007335	\$ 116.35
1000-64-622-43430	217784	ENERGY WEST RESOURCES INC	83	I11-007335	\$ 22.08
1000-64-633-43430	217784	ENERGY WEST RESOURCES INC	83	I11-007335	\$ 193.88
1000-00-000-12400	217788	FILLIATER, TAMMY	13571	I12-003502	\$ 320.00
1000-64-633-43710	217789	FISHER DENNIS	13428	I12-003436	\$ 26.36
1000-14-141-42290	217790	FLEET SUPPLY COMPANY	64	I12-003294	\$ 24.19
1000-64-633-43710	217791	FLOERCHINGER, KARISSA	13568	I12-003445	\$ 92.13
1000-00-000-12400	217804	HABEL PAT	9326	I12-003513	\$ 644.09
1000-64-633-43710	217805	HEARD, KRYSTAL	13566	I12-003438	\$ 138.20
1000-00-000-12400	217807	HOLLAND RON	9897	I12-003508	\$ 435.96
1000-14-141-42290	217814	J & V RESTAURANT & FIRE SUPPLY	6109	I12-003287	\$ 38.80
1000-00-000-21400	217815	JAMES TALLEY	3702	I12-003467	\$ 570.00
1000-00-000-21422	217816	James Thompson	12707	I12-003259	\$ 200.00
1000-00-000-12400	217817	JANIKULA STEFFEN	13514	I12-003498	\$ 103.90
1000-14-141-42290	217818	JOHNSON MADISON LUMBER INC	9	I12-003289	\$ 7.44
1000-00-000-12400	217819	JOHNSON RICK	2270	I12-003506	\$ 435.96
1000-00-000-12400	217822	JUDGE MIKE	8696	I12-003515	\$ 435.96
1000-00-000-21422	217823	Kelli Engelhardt	12707	I12-003254	\$ 200.00
1000-00-000-21421	217824	Kirk Neels	12707	I12-003240	\$ 15.00
1000-64-633-42290	217827	LAWSON PRODUCTS INC	6589	I12-003561	\$ 267.48
1000-14-114-42190	217830	MASTERCARD PROCESSING CENTER	8270	I12-003252	\$ 33.77
1000-14-141-42290	217830	MASTERCARD PROCESSING CENTER	8270	I12-003299	\$ 24.40
1000-14-141-42290	217830	MASTERCARD PROCESSING CENTER	8270	I12-003299	\$ 199.50
1000-14-141-42230	217830	MASTERCARD PROCESSING CENTER	8270	I12-003299	\$ 235.36
1000-14-141-42290	217830	MASTERCARD PROCESSING CENTER	8270	I12-003299	\$ 216.64
1000-14-141-42230	217830	MASTERCARD PROCESSING CENTER	8270	I12-003299	\$ 27.96
1000-14-141-42290	217830	MASTERCARD PROCESSING CENTER	8270	I12-003299	\$ 3.09
1000-14-141-42290	217830	MASTERCARD PROCESSING CENTER	8270	I12-003299	\$ 89.94

City of Great Falls

Check Details Report (Date: 09/14/2011)

Account#	Check#	VendorName	Vendor#	Invoice#	Amount
1000-14-141-42230	217830	MASTERCARD PROCESSING CENTER	8270	I12-003299	\$ 30.25
1000-14-141-42290	217830	MASTERCARD PROCESSING CENTER	8270	I12-003299	\$ 16.99
1000-14-141-42190	217830	MASTERCARD PROCESSING CENTER	8270	I12-003299	\$ 221.95
1000-14-141-42190	217830	MASTERCARD PROCESSING CENTER	8270	I12-003299	\$ 32.42
1000-14-141-42230	217830	MASTERCARD PROCESSING CENTER	8270	I12-003299	\$ 30.29
1000-14-141-42230	217830	MASTERCARD PROCESSING CENTER	8270	I12-003299	\$ 28.82
1000-14-141-42290	217830	MASTERCARD PROCESSING CENTER	8270	I12-003299	\$ 149.97
1000-14-141-42120	217830	MASTERCARD PROCESSING CENTER	8270	I12-003299	\$ 60.95
1000-14-141-42290	217830	MASTERCARD PROCESSING CENTER	8270	I12-003299	\$ 32.85
1000-14-141-42290	217830	MASTERCARD PROCESSING CENTER	8270	I12-003299	\$ 52.47
1000-14-141-42190	217830	MASTERCARD PROCESSING CENTER	8270	I12-003299	\$ 72.76
1000-14-141-42290	217830	MASTERCARD PROCESSING CENTER	8270	I12-003299	\$ 9.88
1000-14-141-42290	217830	MASTERCARD PROCESSING CENTER	8270	I12-003299	\$ 66.99
1000-14-141-42190	217830	MASTERCARD PROCESSING CENTER	8270	I12-003299	\$ 49.99
1000-14-141-42290	217830	MASTERCARD PROCESSING CENTER	8270	I12-003299	\$ 66.96
1000-14-141-42290	217830	MASTERCARD PROCESSING CENTER	8270	I12-003299	\$ 33.82
1000-21-327-42290	217830	MASTERCARD PROCESSING CENTER	8270	I12-003314	\$ 5.37
1000-21-327-42290	217830	MASTERCARD PROCESSING CENTER	8270	I12-003314	\$ 114.61
1000-21-326-42240	217830	MASTERCARD PROCESSING CENTER	8270	I12-003356	\$ 104.96
1000-21-391-43590	217830	MASTERCARD PROCESSING CENTER	8270	I12-003431	\$ 957.00
1000-21-391-43590	217830	MASTERCARD PROCESSING CENTER	8270	I12-003496	\$ 19.28
1000-15-281-43320	217832	MONTANA INTERACTIVE LLC	12485	I12-003555	\$ 25.00
1000-64-633-43445	217834	MONTANA WASTE SYSTEMS INC	8467	I12-003290	\$ 260.38
1000-14-173-43520	217837	MOULTON BELLINGHAM PC	13512	I12-003529	\$ 8,646.08
1000-21-326-43350	217841	MT LAW ENFORCEMENT TESTING CONSORTIUM	12647	I12-003354	\$ 150.00
1000-14-114-43590	217843	MUNICIPAL CODE CORPORATION	13485	I12-003250	\$ 1,796.06
1000-15-281-43526	217844	MUNICIPAL SERVICES BUREAU	9283	I12-003534	\$ 552.40
1000-00-000-21421	217847	Neal Martin	12707	I12-003251	\$ 15.00
1000-00-000-21422	217847	Neal Martin	12707	I12-003251	\$ 100.00

City of Great Falls

Check Details Report (Date: 09/14/2011)

Account#	Check#	VendorName	Vendor#	Invoice#	Amount
1000-21-311-43590	217848	NEW WORLD SYSTEMS CORPORATION	7183	I12-003271	\$ 1,519.16
1000-64-621-43420	217851	NORTHWESTERN ENERGY	82	I12-003253	\$ 21.08
1000-64-621-43350	217852	NRPA	4422	I12-003583	\$ 150.00
1000-64-633-43710	217856	PARKER, PAISLEY	13569	I12-003446	\$ 107.67
1000-00-000-12400	217858	PERMANN KEN	13506	I12-003499	\$ 103.90
1000-21-315-42190	217860	PICKWICK'S OFFICE WORKS INC	367	I12-003269	\$ 159.80
1000-21-311-42190	217860	PICKWICK'S OFFICE WORKS INC	367	I12-003269	\$ 27.32
1000-14-141-42190	217860	PICKWICK'S OFFICE WORKS INC	367	I12-003291	\$ 29.25
1000-14-141-42290	217860	PICKWICK'S OFFICE WORKS INC	367	I12-003292	\$ 152.76
1000-14-171-42190	217860	PICKWICK'S OFFICE WORKS INC	367	I12-003413	\$ 16.20
1000-14-171-42190	217860	PICKWICK'S OFFICE WORKS INC	367	I12-003457	\$ 20.96
1000-21-315-42190	217860	PICKWICK'S OFFICE WORKS INC	367	I12-003471	\$ -159.80
1000-14-111-42190	217860	PICKWICK'S OFFICE WORKS INC	367	I12-003519	\$ 8.50
1000-14-111-42190	217860	PICKWICK'S OFFICE WORKS INC	367	I12-003522	\$ 915.00
1000-15-281-42190	217860	PICKWICK'S OFFICE WORKS INC	367	I12-003537	\$ 42.00
1000-14-141-43412	217869	QWEST COMMUNICATIONS COMPANY LLC	9903	I12-003286	\$ 310.41
1000-00-000-12400	217870	RAPPE RANDY	7327	I12-003512	\$ 495.96
1000-00-000-21422	217871	Rebekah Wipf	12707	I12-003244	\$ 200.00
1000-00-000-12400	217872	REICHEL T JENNIFER	13443	I12-003535	\$ 1,162.30
1000-00-000-12400	217876	RODGER SCOTT	4493	I12-003503	\$ 568.22
1000-21-314-43590	217878	S & C AUTO INC	289	I12-003341	\$ 365.00
1000-21-314-43590	217878	S & C AUTO INC	289	I12-003343	\$ 220.00
1000-00-000-21421	217881	Sherri Clark	12707	I12-003239	\$ 15.00
1000-00-000-21422	217881	Sherri Clark	12707	I12-003239	\$ 200.00
1000-14-141-43110	217882	SHIP-IT	137	I12-003296	\$ 20.64
1000-14-141-42290	217887	SMITH EQUIPMENT CO	2317	I12-003288	\$ 101.00
1000-00-000-12400	217888	SNEDIGAR HENRY	11086	I12-003504	\$ 320.00
1000-64-633-42290	217892	STROBELS RENTALS INC	32	I12-003550	\$ 5.00
1000-15-283-43520	217895	SUTTON MEGHAN	11443	I12-003536	\$ 170.00

City of Great Falls

Check Details Report (Date: 09/14/2011)

Account#	Check#	VendorName	Vendor#	Invoice#	Amount
1000-00-000-21422	217905	Tom Halloran	12707	I12-003261	\$ 200.00
1000-21-311-43415	217910	VERIZON WIRELESS	10858	I12-003272	\$ 33.03
1000-21-312-43415	217910	VERIZON WIRELESS	10858	I12-003272	\$ 167.08
1000-21-314-43415	217910	VERIZON WIRELESS	10858	I12-003272	\$ 135.30
1000-21-315-43415	217910	VERIZON WIRELESS	10858	I12-003272	\$ 666.70
1000-21-324-43415	217910	VERIZON WIRELESS	10858	I12-003272	\$ 35.24
1000-21-325-43415	217910	VERIZON WIRELESS	10858	I12-003272	\$ 66.40
1000-21-341-43412	217910	VERIZON WIRELESS	10858	I12-003272	\$ 132.46
1000-14-171-43410	217910	VERIZON WIRELESS	10858	I12-003458	\$ 156.48
1000-14-111-43415	217910	VERIZON WIRELESS	10858	I12-003520	\$ 123.08
1000-14-112-43415	217910	VERIZON WIRELESS	10858	I12-003520	\$ 61.56
1000-15-281-43410	217911	VISION NET INC	11369	I12-003624	\$ 249.00
1000-64-633-42290	217913	WILBUR-ELLIS COMPANY	1652	I12-003553	\$ 760.00
1000-64-633-42290	217913	WILBUR-ELLIS COMPANY	1652	I12-003553	\$ 20.20
1000-64-633-42290	217913	WILBUR-ELLIS COMPANY	1652	I12-003554	\$ 608.00
1000-64-633-42290	217913	WILBUR-ELLIS COMPANY	1652	I12-003557	\$ 64.00

				Fund(1000) Total	\$104,744.56
6010-31-513-42320	217573	BIG SKY HYDRAULICS & MACHINING INC	11168	I12-003099	\$ 1,777.67
6010-31-513-42320	217573	BIG SKY HYDRAULICS & MACHINING INC	11168	I12-003101	\$ 7.96
6010-31-513-42320	217573	BIG SKY HYDRAULICS & MACHINING INC	11168	I12-003102	\$ 4.14
6010-31-513-42320	217573	BIG SKY HYDRAULICS & MACHINING INC	11168	I12-003103	\$ 22.30
6010-31-513-43410	217585	CENTURYLINK - QWEST CORPORATION	81	I12-003024	\$ 101.62
6010-31-513-43560	217587	CHEMNET CONSORTIUM INC (THE)	11998	I12-002942	\$ 49.50
6010-31-513-42320	217613	FLEET SUPPLY COMPANY	64	I12-003105	\$ 29.70
6010-31-513-42320	217616	GLACIER STATE ELECTRIC SUPPLY	67	I12-003107	\$ 15.75
6010-31-513-42320	217626	HOVEN EQUIPMENT COMPANY	2095	I12-003104	\$ 20.18
6010-31-513-42320	217626	HOVEN EQUIPMENT COMPANY	2095	I12-003108	\$ 606.67
6010-31-513-42320	217627	I STATE TRUCK CENTER INC	11353	I12-003109	\$ 53.61
6010-31-513-42320	217627	I STATE TRUCK CENTER INC	11353	I12-003110	\$ 92.00
6010-31-513-42320	217627	I STATE TRUCK CENTER INC	11353	I12-003111	\$ 105.92

City of Great Falls

Check Details Report (Date: 09/14/2011)

Account#	Check#	VendorName	Vendor#	Invoice#	Amount
6010-31-513-42320	217627	I STATE TRUCK CENTER INC	11353	I12-003112	\$ 305.29
6010-00-000-15110	217655	NAPA AUTO PARTS OF GREAT FALLS	68	I12-003071	\$ 499.82
6010-31-513-42320	217655	NAPA AUTO PARTS OF GREAT FALLS	68	I12-003094	\$ 137.57
6010-31-513-42320	217655	NAPA AUTO PARTS OF GREAT FALLS	68	I12-003095	\$ 4.31
6010-31-513-42320	217656	NATIONAL COATINGS & SUPPLIES	13264	I12-003113	\$ 48.94
6010-31-513-45390	217657	NATIONAL LAUNDRY	388	I12-003128	\$ 85.57
6010-31-513-45390	217657	NATIONAL LAUNDRY	388	I12-003131	\$ 42.47
6010-31-513-42320	217663	OREILLY AUTO PARTS	12052	I12-002572	\$ 3.99
6010-31-513-42320	217663	OREILLY AUTO PARTS	12052	I12-003092	\$ 45.98
6010-31-513-42320	217665	PACIFIC STEEL	22	I12-003115	\$ 21.94
6010-31-513-42190	217669	PICKWICK'S OFFICE WORKS INC	367	I12-003187	\$ 11.72
6010-31-513-42320	217670	POWER PRO EQUIPMENT CO	8197	I12-003116	\$ 16.40
6010-31-513-42320	217689	SUPERIOR TIRE INC	10829	I12-003118	\$ 1,550.00
6010-31-513-43640	217689	SUPERIOR TIRE INC	10829	I12-003119	\$ 139.50
6010-31-513-42320	217689	SUPERIOR TIRE INC	10829	I12-003120	\$ 656.82
6010-31-513-42320	217699	TITAN MACHINERY INC	75	I12-003121	\$ 62.31
6010-31-513-42320	217705	VALLEY MOTOR SUPPLY CO INC	71	I12-002579	\$ 9.43
6010-31-513-43415	217706	VERIZON WIRELESS	10858	I12-003191	\$ 129.12
6010-31-513-42320	217717	ACE HARDWARE	4876	I12-003220	\$ 13.50
6010-31-513-42320	217717	ACE HARDWARE	4876	I12-003221	\$ 20.97
6010-31-513-42290	217717	ACE HARDWARE	4876	I12-003221	\$ 28.97
6010-31-513-42320	217717	ACE HARDWARE	4876	I12-003351	\$ 29.99
6010-31-513-42320	217717	ACE HARDWARE	4876	I12-003351	\$ 29.99
6010-31-513-42320	217717	ACE HARDWARE	4876	I12-003352	\$ 39.37
6010-31-513-42410	217719	AMERICAN WELDING & GAS INC (VALLEY)	72	I12-003359	\$ 8.03
6010-00-000-15110	217730	BEST OIL DISTRIBUTING	8163	I12-003337	\$ 2,467.50
6010-31-513-42410	217731	BIG R STORES (CSWW INC)	40	I12-003360	\$ 7.99
6010-31-513-42320	217732	BIG SKY FIRE/AFFIRMED MEDICAL	2129	I12-003412	\$ 193.99
6010-31-513-42290	217732	BIG SKY FIRE/AFFIRMED MEDICAL	2129	I12-003579	\$ 10.58

City of Great Falls

Check Details Report (Date: 09/14/2011)

Account#	Check#	VendorName	Vendor#	Invoice#	Amount
6010-31-513-42320	217733	BIG SKY HYDRAULICS & MACHINING INC	11168	I12-003361	\$ 734.51
6010-31-513-42320	217733	BIG SKY HYDRAULICS & MACHINING INC	11168	I12-003363	\$ 51.76
6010-31-513-42320	217733	BIG SKY HYDRAULICS & MACHINING INC	11168	I12-003364	\$ 99.72
6010-31-513-42320	217733	BIG SKY HYDRAULICS & MACHINING INC	11168	I12-003546	\$ 25.72
6010-31-513-42320	217733	BIG SKY HYDRAULICS & MACHINING INC	11168	I12-003547	\$ 55.80
6010-31-513-42290	217740	BREEN OIL COMPANY	10408	I12-003325	\$ 24.30
6010-31-513-42320	217743	BROCK WHITE COMPANY LLC	10555	I12-003382	\$ 1,955.87
6010-31-513-43620	217750	CALVERTS OVERHEAD DOOR SERVICE	11134	I12-003264	\$ 204.00
6010-31-513-42320	217751	CAPITAL COMMUNICATIONS	13091	I12-003326	\$ 1,785.00
6010-31-513-43355	217754	CASCADE COUNTY TREASURER	1239	I12-003568	\$ 25.00
6010-31-513-42320	217772	DIRECT AUTOMOTIVE DISTRIBUTING	13156	I12-003222	\$ -60.00
6010-31-513-42320	217772	DIRECT AUTOMOTIVE DISTRIBUTING	13156	I12-003223	\$ 257.99
6010-31-513-42320	217772	DIRECT AUTOMOTIVE DISTRIBUTING	13156	I12-003224	\$ 66.58
6010-00-000-15110	217772	DIRECT AUTOMOTIVE DISTRIBUTING	13156	I12-003339	\$ 801.10
6010-31-513-42320	217772	DIRECT AUTOMOTIVE DISTRIBUTING	13156	I12-003383	\$ 19.59
6010-31-513-42320	217772	DIRECT AUTOMOTIVE DISTRIBUTING	13156	I12-003384	\$ 87.54
6010-31-513-42320	217772	DIRECT AUTOMOTIVE DISTRIBUTING	13156	I12-003385	\$ 13.38
6010-31-513-42320	217783	ENERGY EQUIPMENT & SUPPLY INC	13419	I12-003548	\$ 559.35
6010-31-513-42320	217785	FASTENAL COMPANY	7664	I12-003225	\$ 10.67
6010-31-513-42290	217785	FASTENAL COMPANY	7664	I12-003386	\$ 64.54
6010-31-513-42320	217790	FLEET SUPPLY COMPANY	64	I12-003226	\$ 21.18
6010-31-513-42320	217790	FLEET SUPPLY COMPANY	64	I12-003387	\$ 15.40
6010-31-513-42290	217794	GENERAL DISTRIBUTING CO	65	I12-003227	\$ 26.97
6010-31-513-42290	217794	GENERAL DISTRIBUTING CO	65	I12-003388	\$ 72.30
6010-31-513-42290	217794	GENERAL DISTRIBUTING CO	65	I12-003389	\$ 66.00
6010-31-513-42290	217794	GENERAL DISTRIBUTING CO	65	I12-003390	\$ 36.87
6010-31-513-42320	217808	HOVEN EQUIPMENT COMPANY	2095	I12-003391	\$ 10.62
6010-31-513-42320	217808	HOVEN EQUIPMENT COMPANY	2095	I12-003392	\$ 66.26
6010-31-513-42320	217809	HUGHES FIRE EQUIPMENT INC	6714	I12-003393	\$ 240.08
6010-31-513-42320	217809	HUGHES FIRE EQUIPMENT INC	6714	I12-003394	\$ 152.01

City of Great Falls

Check Details Report (Date: 09/14/2011)

Account#	Check#	VendorName	Vendor#	Invoice#	Amount
6010-31-513-42320	217810	I STATE TRUCK CENTER INC	11353	I12-003228	\$ 68.72
6010-31-513-42320	217810	I STATE TRUCK CENTER INC	11353	I12-003400	\$ 93.12
6010-31-513-42320	217810	I STATE TRUCK CENTER INC	11353	I12-003401	\$ 59.40
6010-31-513-42320	217810	I STATE TRUCK CENTER INC	11353	I12-003403	\$ 82.21
6010-31-513-42320	217810	I STATE TRUCK CENTER INC	11353	I12-003578	\$ 83.58
6010-00-000-15110	217810	I STATE TRUCK CENTER INC	11353	I12-003649	\$ 46.68
6010-00-000-15110	217810	I STATE TRUCK CENTER INC	11353	I12-003650	\$ 121.44
6010-00-000-15110	217810	I STATE TRUCK CENTER INC	11353	I12-003651	\$ 378.48
6010-31-513-42290	217811	IBS INC	9419	I12-003396	\$ 221.25
6010-00-000-15110	217825	KOIS BROTHERS EQUIPMENT CO	643	I12-003333	\$ 164.55
6010-31-513-43690	217835	MOSCH ELECTRIC MOTORS INC	118	I12-003542	\$ 8.00
6010-31-513-42320	217836	MOTOR POWER GREAT FALLS INC	9731	I12-003417	\$ 122.38
6010-00-000-15120	217838	MOUNTAIN VIEW CO-OP	972	I12-003334	\$ 23,401.30
6010-00-000-15120	217838	MOUNTAIN VIEW CO-OP	972	I12-003335	\$ 18,965.70
6010-00-000-15120	217838	MOUNTAIN VIEW CO-OP	972	I12-003336	\$ 8,694.94
6010-00-000-15120	217838	MOUNTAIN VIEW CO-OP	972	I12-003648	\$ 24,327.75
6010-31-513-42290	217845	NAPA AUTO PARTS OF GREAT FALLS	68	I12-003217	\$ 5.98
6010-31-513-42320	217845	NAPA AUTO PARTS OF GREAT FALLS	68	I12-003218	\$ 26.29
6010-31-513-42320	217845	NAPA AUTO PARTS OF GREAT FALLS	68	I12-003219	\$ -2.27
6010-31-513-42320	217845	NAPA AUTO PARTS OF GREAT FALLS	68	I12-003329	\$ 5.69
6010-31-513-42320	217845	NAPA AUTO PARTS OF GREAT FALLS	68	I12-003330	\$ 17.72
6010-31-513-42320	217845	NAPA AUTO PARTS OF GREAT FALLS	68	I12-003346	\$ 114.06
6010-31-513-42320	217845	NAPA AUTO PARTS OF GREAT FALLS	68	I12-003348	\$ 9.71
6010-00-000-15110	217845	NAPA AUTO PARTS OF GREAT FALLS	68	I12-003647	\$ 69.32
6010-31-513-45390	217846	NATIONAL LAUNDRY	388	I12-003315	\$ 75.19
6010-31-513-45390	217846	NATIONAL LAUNDRY	388	I12-003517	\$ 45.40
6010-31-513-42320	217854	OREILLY AUTO PARTS	12052	I12-003214	\$ 14.98
6010-31-513-42320	217854	OREILLY AUTO PARTS	12052	I12-003215	\$ 32.95
6010-31-513-42320	217854	OREILLY AUTO PARTS	12052	I12-003216	\$ -32.95
6010-31-513-42320	217854	OREILLY AUTO PARTS	12052	I12-003316	\$ 44.63

City of Great Falls

Check Details Report (Date: 09/14/2011)

Account#	Check#	VendorName	Vendor#	Invoice#	Amount
6010-31-513-42320	217854	OREILLY AUTO PARTS	12052	I12-003317	\$ 183.56
6010-31-513-42290	217854	OREILLY AUTO PARTS	12052	I12-003322	\$ 6.49
6010-00-000-15110	217854	OREILLY AUTO PARTS	12052	I12-003652	\$ 59.06
6010-00-000-15110	217854	OREILLY AUTO PARTS	12052	I12-003653	\$ 43.95
6010-31-513-42320	217855	PACIFIC STEEL	22	I12-003418	\$ 359.74
6010-31-513-43640	217857	PAT'S AUTO BODY	845	I12-003310	\$ 903.50
6010-31-513-42190	217860	PICKWICK'S OFFICE WORKS INC	367	I12-003449	\$ 25.32
6010-31-513-42190	217860	PICKWICK'S OFFICE WORKS INC	367	I12-003541	\$ 26.24
6010-31-513-42320	217865	PROBUILD	25	I12-003551	\$ 10.58
6010-31-513-42320	217874	RMT EQUIPMENT	13548	I12-003552	\$ 101.51
6010-31-513-42320	217875	ROCKY MOUNTAIN TRUCK SERVICE INC	9846	I12-003229	\$ 77.42
6010-31-513-42320	217875	ROCKY MOUNTAIN TRUCK SERVICE INC	9846	I12-003556	\$ 120.98
6010-31-513-42320	217879	SAFELITE FULFILLMENT INC	8371	I12-003558	\$ 360.00
6010-31-513-42320	217879	SAFELITE FULFILLMENT INC	8371	I12-003559	\$ 170.00
6010-31-513-42320	217879	SAFELITE FULFILLMENT INC	8371	I12-003560	\$ 180.00
6010-31-513-42320	217879	SAFELITE FULFILLMENT INC	8371	I12-003572	\$ 180.00
6010-31-513-42410	217886	SIX ROBBLEES INC	21	I12-003230	\$ 36.10
6010-00-000-15110	217886	SIX ROBBLEES INC	21	I12-003646	\$ 42.33
6010-31-513-42320	217887	SMITH EQUIPMENT CO	2317	I12-003406	\$ 34.00
6010-31-513-42320	217887	SMITH EQUIPMENT CO	2317	I12-003408	\$ 69.00
6010-31-513-42320	217887	SMITH EQUIPMENT CO	2317	I12-003410	\$ 3.00
6010-00-000-15110	217894	SUPERIOR TIRE INC	10829	I12-003331	\$ 16,210.40
6010-31-513-43640	217894	SUPERIOR TIRE INC	10829	I12-003420	\$ 45.50
6010-31-513-42320	217894	SUPERIOR TIRE INC	10829	I12-003423	\$ 117.97
6010-31-513-43640	217894	SUPERIOR TIRE INC	10829	I12-003573	\$ 113.90
6010-31-513-42320	217896	TAYLOR BROTHERS INC	180	I12-003574	\$ 202.81
6010-31-513-42320	217902	TIRE FACTORY	9864	I12-003350	\$ 280.00
6010-31-513-42320	217903	TITAN MACHINERY INC	75	I12-003231	\$ 488.76
6010-00-000-15110	217903	TITAN MACHINERY INC	75	I12-003332	\$ 1,842.86
6010-31-513-42320	217903	TITAN MACHINERY INC	75	I12-003424	\$ 73.22

City of Great Falls

Check Details Report (Date: 09/14/2011)

Account#	Check#	VendorName	Vendor#	Invoice#	Amount
6010-31-513-42320	217903	TITAN MACHINERY INC	75	I12-003575	\$ 1,726.43
6010-00-000-15110	217904	TNT SPRINGS INC / TNT TRUCK PARTS	12089	I12-003338	\$ 1,090.00
6010-31-513-42320	217904	TNT SPRINGS INC / TNT TRUCK PARTS	12089	I12-003427	\$ 290.90
6010-31-513-42320	217907	TRACTOR & EQUIPMENT CO	69	I12-003576	\$ 92.04
6010-31-513-42320	217907	TRACTOR & EQUIPMENT CO	69	I12-003577	\$ -63.93

Fund(6010) Total\$119,769.03

Grand Total\$2,069,048.64

CITY OF GREAT FALLS, MONTANA

AGENDA: 8

COMMUNICATION TO THE CITY COMMISSION

DATE: September 20, 2011

ITEM: CONTRACTS LIST
Itemizing contracts not otherwise approved or ratified by City Commission Action
(Listed contracts are available for inspection in the City Clerk's Office.)

PRESENTED BY: Lisa Kunz, City Clerk

ACTION REQUESTED: Ratification of Contracts through the Consent Agenda

MAYOR'S SIGNATURE: _____

CONTRACTS LIST

	DEPARTMENT	OTHER PARTY (PERSON OR ENTITY)	PERIOD	FUND	AMOUNT	PURPOSE
A	Planning and Community Development	FallsWindows and Doors	09/15/2011 – 12/15/2011	5725-71-725-43620	\$1,840	Contractor Agreement to replace a damaged door frame and door in the stairwell of the North Parking Garage.

B	Planning and Community Development	Hands, Inc.	07/01/2011 – 06/30/2011	2940	\$15,283	2011/2012 CDBG Agreement, re: provide child care scholarships for low income families.
C	Public Works – Engineering	Poncelet Landscape and Excavating	09/2011	Sanitary Sewer Improvements Other Than Buildings	\$7,250	Contractor Agreement to repair sags in existing sanitary sewer main located at the intersection of 5 th Avenue SW and 19 th Street SW; work to be done in conjunction with sanitary sewer main extension project to serve new development. OF 1563

**CITY OF GREAT FALLS, MONTANA
COMMUNICATION TO THE CITY COMMISSION**

**AGENDA: 9
DATE: September 20, 2011**

ITEM: GRANT LIST
Itemizing grants not otherwise approved or ratified by City Commission Action
(Listed grants are available for inspection in the City Clerk’s Office.)

PRESENTED BY: Lisa Kunz, City Clerk

ACTION REQUESTED: Ratification of Grants through the Consent Agenda

MAYOR’S SIGNATURE: _____

GRANTS

	DEPARTMENT	OTHER PARTY (PERSON OR ENTITY)	PERIOD	GRANT AMOUNT REQUESTED	CITY MATCH (INCLUDE FUND MATCH TO BE PAID OUT OF)	PURPOSE
A	Great Falls Fire Rescue	Department of Homeland Security	2011 – 2012	\$86,090	\$17,218	Assistance to Firefighters Grant for firefighter occupational wellness and fitness program.
B	Public Works	Montana Department of Transportation	2011	\$165,848 (Or 85.6% of the actual cost of the equipment)	\$25,707 (Or 13.42% of the actual cost of the equipment)	Montana Air and Congestion Initiative (MACI) grant project for air quality equipment.



Item: One New 2012 Tandem Axle Dump Truck
From: Tom Hugg, Vehicle Maintenance Supervisor
Initiated By: Public Works Department
Presented By: Jim Rearden, Public Works Director
Action Requested: Award Bid

Suggested Motion:

1. Commissioner moves:

“I move that the City Commission (approve/reject) the bid award for one new 2012 tandem axle dump truck to I-State Truck Center of Great Falls for \$95,871.00.”

2. Mayor calls for a second, discussion, inquiries from the public, and calls for the vote.

Staff Recommendation: Staff recommends that the City Commission approve the bid award for one new 2012 tandem axle dump truck to I-State Truck Center of Great Falls for \$95,871.00.

Background:

Purpose

This unit will be used in the Street Division Maintenance Program.

Evaluation and Selection Process

The specifications were advertised two times in the Great Falls Tribune, placed on the City of Great Falls website, and mailed to eight prospective bidders. The bids were opened on September 7, 2011 with two bidders responding, one with three bids and the other with two bids.

The vehicle being replaced will be sold at a later date. It is a 1993 Freightliner Tandem Axle Dump Truck with 106,000 miles and over 10,000 hours.

Conclusion

The bid by I-State Truck Center of Great Falls was the low bid and meets specifications for the tandem axle dump truck.

Fiscal Impact: Funds for this scheduled purchase from the ERS (Equipment Revolving Schedule) were provided in the FY 2012 Central Garage Budget.

Alternatives: Reject the bids for the purchase of one new 2012 tandem axle dump truck.

Attachments/Exhibits: Bid List, Bid Tab

Dump Truck Bid List

Tri-State Equipment
5024 Tri-Hill Frontage Road
Great Falls MT 59404

I State Truck Center
PO Box 2165
Great Falls MT 59403

Motor Power Great Falls
PO Box 2264
Great Falls MT 59403

Montana Peterbilt
PO Box 16455
Missoula, MT 59808

Tractor & Equipment
4001 River Drive North
Great Falls MT 59405

Kois Brothers Equipment
PO Box 1728
Great Falls MT 59403

HCL Equipment
2417 Old Havre Hwy
Black Eagle MT 59414

3-V Distributing, Inc.
PO Box 955
Conrad MT 59425



Item: Five New Section Snow Plows
From: Tom Hugg, Vehicle Maintenance Supervisor
Initiated By: Public Works Department
Presented By: Jim Rearden, Public Works Director
Action Requested: Award Bid

Suggested Motion:

1. Commissioner moves:

“I move that the City Commission (approve/reject) the bid award for five new section snow plows to Kois Brothers of Great Falls for \$76,425.00.”

2. Mayor calls for a second, discussion, inquiries from the public, and calls for the vote.

Staff Recommendation: Staff recommends that the City Commission approve the bid award for five new section snow plows to Kois Brothers of Great Falls for \$76,425.00.

Background:

Purpose

These units will be used in the Street Division Snow & Ice Control Program.

Evaluation and Selection Process

The specifications were advertised two times in the Great Falls Tribune, placed on the City of Great Falls website, and mailed to four prospective bidders. The bids were opened on September 7, 2011 with one bidder responding.

The snow plows being replaced have no trade-in value. There are (4) 1996 and (1) 1993. The mainframe structure and hydraulic component repair is estimated at \$8,000-\$10,000 each. They will be used for parts on the new plows. This will also allow the division to have a reserve plow ready to help cover downtime.

Conclusion

The bid by Kois Brothers of Great Falls meets specifications for the section snow plows.

Fiscal Impact: Funds for this scheduled purchase from the ERS (Equipment Revolving Schedule) were provided in the FY 2012 Central Garage Budget.

Alternatives: Reject the bids for the purchase of five new section snow plows.

Attachments/Exhibits: Bid List, Bid Tab

Snow Plow and Sanders Bid List

Kois Brothers Equipment
PO Box 1728
Great Falls MT 59403

HCL Equipment
2417 Old Havre Hwy
Black Eagle MT 59414

3-V Distributing, Inc.
PO Box 955
Conrad MT 59425

Normont Equipment Co.
1157 Wire Mill Road
Black Eagle MT 59414



Agenda # 12
Commission Meeting Date:
September 20, 2011

**CITY OF GREAT FALLS
COMMISSION AGENDA REPORT**

Item: Change Order No. 1 – 21st Avenue NE Drainage Improvements, O.F. 1573.6

From: Engineering Division

Initiated By: Public Works Department

Presented By: Jim Rearden, Public Works Director

Action Requested: Approve Change Order No. 1

Suggested Motion:

1. Commissioner moves:

"I move the City Commission approve Change Order No. 1 in the amount of \$10,112.43 for the 21st Avenue NE Drainage Improvements, O. F. 1573.6, to United Materials of Great Falls, Inc. and authorize the City Manager to execute the agreements."

2. Mayor calls for a second, discussion, inquiries from the public, and calls for the vote.

Staff Recommendation: Approve Change Order No. 1.

Background:

Significant Impacts: This change order involves additional excavation and reinforcement of the subgrade found under the road and additional concrete driveway and sodding required to better match the new curb and gutter grades.

Workload Impacts: Public Works staff designed the project, and are performing construction inspection and contract administration duties.

Purpose: This block of street had developed drainage problems due to settlements that had occurred due to poor soil conditions in the area. Curb and gutter grades no longer allowed water to flow to the existing drainage inlets intended for the road, and pools of standing water developed frequently, further undermining the curb and street. This project replaced the existing curb and gutter and adjusted the flowline grades to allow for proper road drainage. The existing road section was also replaced and reinforced with a geogrid along with a thicker base course. The new road section will better withstand traffic loads and limit settlement caused by poor subbase conditions. Due to the curb adjustments, the adjacent sidewalks and driveways needed to be replaced as well. Change Order No. 1 adds approximately 232 cubic yards of over-excavation and

replacement with large gravel base course. The work was done at the contract unit price of \$31.75 per cubic yard. The over-excavation was necessary due to large amounts of non-loadbearing clay soil found under the road section. Without replacing the clay soil and providing additional reinforcement, the new road section would have a greatly reduced lifespan. 438 square feet of driveway and 238 square feet of sod was also added to better match the new curb and gutter grades and minimize slopes. Both of these items were done at the contract unit prices as well.

Project Work Scope: Approximately 2,000 square yards of asphalt was removed and replaced along with 1,140 linear feet of curb and gutter. Geogrid fabric was installed in the new road section under 12-inches of gravel road base. 8,336 square feet of sidewalk and driveways were also replaced with this project.

Evaluation and Selection Process: Six bids were received and opened for this project on May 18, 2011. United Materials submitted the low bid of \$135,480.00. The City Commission awarded the contract June 7, 2011. This change order will increase the total contract value to \$145,592.43

Conclusion: City staff recommends approving Change Order No. 1 to United Materials in the amount of \$10,112.43.

Fiscal Impact:

The additional funding will come from street maintenance funds.

Alternatives:

The City Commission could vote to deny Change Order No. 1.

Attachments/Exhibits:

1. Change Order No. 1 is attached.

Change Order

No. 1

Date of Issuance: September 8, 2011 Effective Date: September 20, 2011

21 st Avenue NE Drainage Improvements (O.F. 1573.6)	Owner: City of Great Falls	Owner's Contract No. : O.F. 1573.6
Contractor: United Materials of Great Falls, Inc.		Date of Contract: June 7, 2011
Address: P.O. Box 1690 Great Falls, MT 59403		Project Number.: 371004

The Contract Documents are modified as follows upon execution of this Change Order:

Additional excavation and reinforcement required due to poor subgrade
Additional concrete driveways added to better match new grades

Attachments: (List documents supporting change):

<u>CHANGE IN CONTRACT PRICE:</u>	<u>CHANGE IN CONTRACT TIMES:</u>
Original Contract Price: \$ <u>135,480.00</u> [Increase] [Decrease] from previously approved Change Orders No. <u>0</u> to No. _____: \$ _____ Contract Price prior to this Change Order: \$ <u>135,480.00</u> [Increase] [Decrease] of this Change Order: \$ <u>+10,112.43</u> Contract Price incorporating this Change Order: \$ <u>145,592.43</u>	Original Contract Times: <input type="checkbox"/> Working days <input checked="" type="checkbox"/> Calendar days Substantial completion (days or date): _____ Ready for final payment (days or date): _____ [Increase] [Decrease] from previously approved Change Orders No. <u>0</u> to No. _____: Substantial completion (days): _____ Ready for final payment (days): _____ Contract Times prior to this Change Order: Substantial completion (days or date): <u>30</u> Ready for final payment (days or date): _____ [Increase] [Decrease] of this Change Order: Substantial completion (days or date): _____ Ready for final payment (days or date): _____ Contract Times with all approved Change Orders: Substantial completion (days or date): <u>30</u> Ready for final payment (days or date): _____

RECOMMENDED:	ACCEPTED:	ACCEPTED:
By: _____ Engineer (Authorized Signature)	By: _____ Owner (Authorized Signature)	By: _____ Contractor (Authorized Signature)
Date: _____	Date: _____	Date: _____
Approved by Funding Agency (if applicable): _____		Date: _____



Item: Police Department Rehabilitation CTEP Project– Change Order 1
From: Andrew Finch, Senior Planner, Planning & Community Development
Initiated By: Police Department / Planning & Community Development Department
Presented By: Mike Haynes, Planning & Community Development Director
Action Requested: Approve Change Order 1 to Dick Olson Construction

Suggested Motion:

1. Commissioner moves:

“I move that the City Commission approve Change Order 1 to Dick Olson Construction in the amount of \$6,038 and extend the contract time by 10 days for the Police Department Rehab Project, and authorize the City Manager to execute the necessary documents.”

2. Mayor calls for a second, discussion, inquiries from the public, and calls the vote.

Staff Recommendation: Approve Change Order 1.

Background: The City Commission awarded a construction contract to Dick Olson Construction, Inc. on May 17, 2011, for repair and rehabilitation of concrete features on the exterior of the Police Department Building. The project is funded by the Community Transportation Enhancement Program (CTEP), with a small percentage (13.42%) provided by the City of Great Falls as required matching dollars.

Scope of Change

A portion of the project includes demolition of the deteriorated surface of the loading dock, and then laying a new concrete surface. However, when demolition began on the ramp, a void was discovered underneath. Because the void is a threat to the structural stability of the ramp, this unanticipated deficiency must be addressed.

The void was likely caused due to settling of the subsurface material under the ramp over the 80+ years since construction. To fix this, the change order would direct the contractor to place “flowable fill” or “pumpable grout fill” underneath the ramp. This is a concrete product that is

more liquid than traditional concrete, allowing it to flow and fill the voids. Upon curing, it would provide a strong support for the ramp.

Significant Impacts

There would be no negative impact to the historic nature of the building, nor to the operation and function of the Police Department.

Workload Impacts

There would be no additional workload impacts to city staff as a result of the change order.

Concurrences: Representatives from the Police Department, the Historic Preservation Officer, the Montana Department of Transportation, and the project engineer, Lacy & Ebeling Engineering, concur in the change order.

Fiscal Impact: The adjusted contract amount, as adjusted by Change Order 1, would be as follows:

Original Contract Amount:	\$127,389.65
Change Order 1 Amount:	\$ 6,038.00 (increase)
Adjusted Contract Amount:	\$133,427.65

Change Order Distribution:

CTEP (86.58%):	\$ 5,227.70
City (13.42%):	\$ 810.30

Federal Funds provided through the CTEP program would provide 86.58% of the change order amount, with the remaining 13.42% provided by the City of Great Falls.

Alternatives: The City Commission could vote to deny Change Order 1, and the ramp would not be stabilized. However, this could adversely affect Police Department Operations that utilize it to access their facility.

Attachments/Exhibits: Change Order 1

Cc: Capt. Tim Shanks, PD
Linda Geranios, PE, L&E

CHANGE ORDER

No. 1

DATE OF ISSUANCE September 20, 2011

EFFECTIVE DATE September 20, 2011

OWNER City of Great Falls
 CONTRACTOR Dick Olson Construction, Inc.
 Contract: Police Department Rehab-GTF; STPE 5299(82)
 OWNER'S Contract No. O.F. 1567 ENGINEER'S Contract No. N/A
 ENGINEER Lacy & Ebeling Engineering, Inc.

You are directed to make the following changes in the Contract Documents:

Description: Increase contract price by \$6,038.00 to \$133,427.65.

Reason for Change Order:

1) Installation of flowable fill (i.e., pumpable grout fill) under ramp for full structural integrity, per attached. Void under ramp was not identified until demolition during contract.

CHANGE IN CONTRACT PRICE:
Original Contract Bid Price \$ <u>\$127,389.65</u>
Net Increase (Decrease) from previous Change Orders: \$ <u>0.00</u>
Contract Price prior to this Change Order: \$ <u>127,389.65</u>
Net increase (decrease) of this Change Order: \$ <u>6,038.00</u>
Contract Price with all approved Change Orders: \$ <u>133,427.65</u>

CHANGE IN CONTRACT TIMES:
Original Contract Times: Substantial Completion: <u>90 days</u> Ready for final payment: _____ (days or dates)
Net change from previous Change Orders No. <u>0</u> to No. <u>1</u> : Substantial Completion: <u>0</u> Ready for final payment: _____ (days)
Contract Times prior to this Change Order: Substantial Completion: <u>90 days</u> Ready for final payment: _____ (days or dates)
Net increase (decrease) this Change Order: Substantial Completion: <u>10</u> Ready for final payment: _____ (days)
Contract Times with all approved Change Orders: Substantial Completion: <u>100 days</u> Ready for final payment: _____ (days or dates)

RECOMMENDED:

APPROVED:

ACCEPTED:

By: _____
ENGINEER (Authorized Signature)

By: _____
OWNER (Authorized Signature)

By: _____
CONTRACTOR (Authorized Signature)

Date: _____

Date: _____

Date: _____

EJCDC 1910-8-B (1996 Edition)

Prepared by the Engineers Joint Contract Document Committee and endorsed by the Associated General Contractors of America and the Construction Specifications Institute.

SECTION 03301 – Pumpable Grout Fill

PART 1 - GENERAL

1.1 RELATED DOCUMENTS

- A. Drawings and general provisions of the Contract, including General and Supplementary Conditions and Division 1 Specification Sections, apply to this Section.

1.2 SUMMARY

- A. This Section specifies pumpable grout fills, mix design, placement procedures, and finishes.

1.3 SUBMITTALS

- A. General: Submit the following according to Conditions of the Contract and Division 1 Specification Sections.
- B. Product data for proprietary materials and items, admixtures, patching compounds, curing compounds, and others if requested by engineer.
- C. Laboratory test reports for concrete materials and mix design test.
- D. Material certificates in lieu of material laboratory test reports when permitted by Architect. Material certificates shall be signed by manufacturer and Contractor, certifying that each material item complies with or exceeds specified requirements. Provide certification from admixture manufacturers that chloride content complies with specification requirements.

PART 2 - PRODUCTS

2.1 CONCRETE MATERIALS

- A. Portland Cement: ASTM C 150, Type I.
 - 1. Use one brand of cement throughout Project unless otherwise acceptable to Architect.
- B. Fly Ash: ASTM C 618, Type F.
- C. Normal-Weight Aggregates: ASTM C 33 and as specified. Provide aggregates from a single source for exposed concrete.
 - 1. For exposed exterior surfaces, do not use fine or coarse aggregates that contain substances that cause spalling.
- D. Water: Potable.
- E. Admixtures, General: Provide concrete admixtures that contain not more than 0.1 percent chloride ions.
- F. Air-Entraining Admixture: ASTM C 260, certified by manufacturer to be compatible with other required admixtures.

1. Available Products: Subject to compliance with requirements, products that may be incorporated in the Work include, but are not limited to, the following:
 - a. Darex AEA or Daravair, W.R. Grace & Co.
 - b. MB-VR or Micro-Air, Master Builders, Inc.
 - c. Sika AER, Sika Corp.

G. Water-Reducing Admixture: ASTM C 494, Type A.

1. Available Products: Subject to compliance with requirements, products that may be incorporated in the Work include, but are not limited to, the following:
 - a. WRDA, W.R. Grace & Co.
 - b. Pozzolith Normal or Polyheed, Master Builders, Inc.
 - c. Prokrete-N, Prokrete Industries.
 - d. Plastocrete 161, Sika Corp.

H. Water-Reducing, Accelerating Admixture: ASTM C 494, Type E.

1. Available Products: Subject to compliance with requirements, products that may be incorporated in the Work include, but are not limited to, the following:
 - a. Daraset, W.R. Grace & Co.
 - b. Pozzutec 20, Master Builders, Inc.

I. Water-Reducing, Retarding Admixture: ASTM C 494, Type D.

1. Available Products: Subject to compliance with requirements, products that may be incorporated in the Work include, but are not limited to, the following:
 - a. Daratard-17, W.R. Grace & Co.
 - b. Pozzolith R, Master Builders, Inc.
 - c. Plastiment, Sika Corporation.

2.2 PROPORTIONING AND DESIGNING MIXES

A. RECOMMENDED BATCH WEIGHTS, PUMPABLE GROUT FILL (LBS/CY)

Component	SSD Aggregate	4% Free Moisture in Sand
Cement.....	190(2.0 sacks).....	190(2.0 sacks)
Fly Ash.....	90.....	90
Water.....	350(42.0 gallons).....	220(26.4 gallons)
Fine Concrete Aggregate.....	3300.....	3430
(ASTM C33)		

Note: The mix should be evaluated after initial batching for actual water demand. The water amount will likely need to be adjusted, and sand quantity should also be adjusted to maintain proper yield.

Note: The use of a high-range water reducing admixture (superplasticizer) is not called for in the mix design. The flowability of the pumpable grout fill will be adjusted by water content. The contractor may add a high-range water-reducing admixture to the mix to aid in placement if desired.

Note: The pumpable grout mix design has not been previously used. The recommended mix proportions are based upon experience with local aggregates and reflects requirements for pumpability and mineral strength. As the mix design has not been trial tested for pumpability, mix adjustments may be required if line packing/plugging occurs.

B. Water-Cement Ratio: Provide concrete for following conditions with maximum water-cement (W/C) ratios as follows:

1. W/C for pumpable grout fill per mix design, subject to increase on site.

C. Slump Limits: Proportion and design mixes to result in concrete slump at point of placement as follows:

1. Pumpable grout fill, unlimited.

D. Adjustment to Concrete Mixes: Mix design adjustments may be requested by Contractor when characteristics of materials, job conditions, weather, test results, or other circumstances warrant, as accepted by Architect. Laboratory test data for revised mix design and strength results must be submitted to and accepted by Architect before using in Work.

2.3 ADMIXTURES

A. Use water-reducing admixture or high-range water-reducing admixture (superplasticizer) in concrete, as required, for placement and workability.

B. Use high-range water-reducing admixture in pumped concrete, concrete for heavy-use industrial slabs, Architectural concrete, parking structure slabs, concrete required to be watertight, and concrete with water-cement ratios below 0.50.

C. Use air-entraining admixture in exterior exposed concrete unless otherwise indicated. Add air-entraining admixture at manufacturer's prescribed rate to result in concrete at point of placement having total air content with a tolerance of plus or minus 1-1/2 percent within the following limits:

1. Concrete structures and slabs exposed to freezing and thawing, deicer chemicals, or hydraulic pressure:

a. 5.0 percent (moderate exposure); 6.0 percent (severe exposure) for 3/4-inch maximum aggregate.

2. Other concrete not exposed to freezing, thawing, or hydraulic pressure, or to receive a surface hardener: 2 to 4 percent air.

D. Use admixtures for water reduction and set accelerating or retarding in strict compliance with manufacturer's directions.

2.4 GROUT MIXING

A. Ready-Mixed Grout: Comply with requirements of ASTM C 94, and as specified.

1. When air temperature is between 85 deg F (30 deg C) and 90 deg F (32 deg C), reduce mixing and delivery time from 1-1/2 hours to 75 minutes, and when air temperature is above 90 deg F

(32 Deg reduce mixing and delivery time to 60 minutes.

PART 3 - EXECUTION

3.1 CONCRETE PLACEMENT

- A. General: Comply with ACI 304, "Guide for Measuring, Mixing, Transporting, and Placing Concrete," and as specified.
- B. See structural sheets for flowable fill installation notes

END OF SECTION 03300

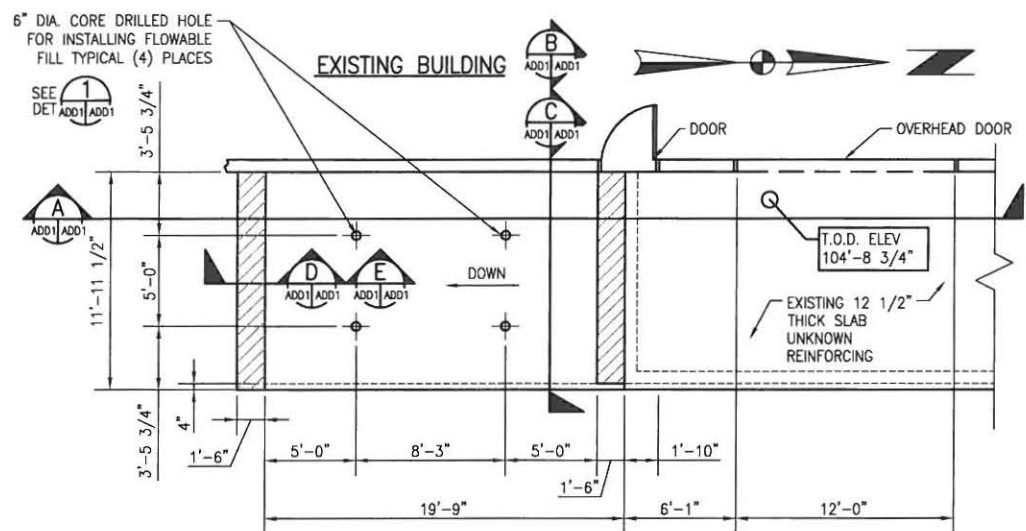

LOADING DOCK PLAN
SCALE: 3/32"=1'-0"

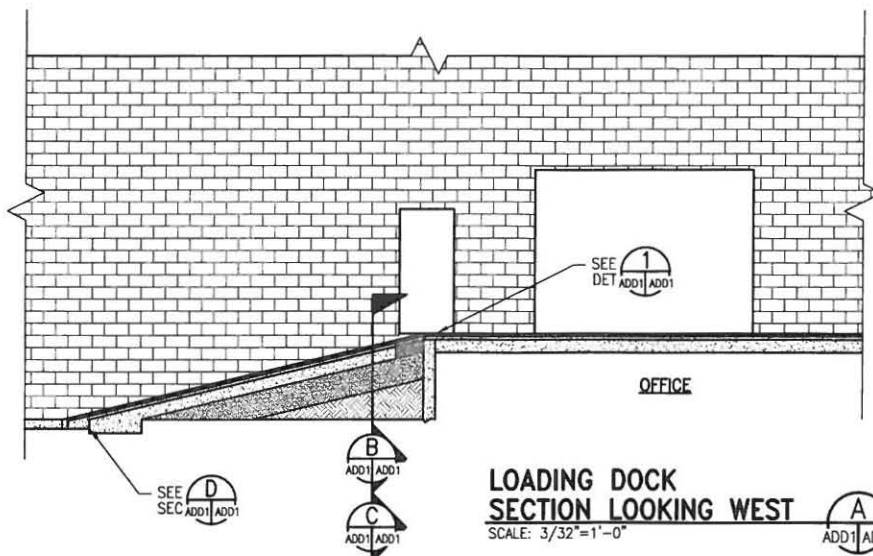

LOADING DOCK SECTION LOOKING WEST
SCALE: 3/32"=1'-0"

FLOWABLE FILL INSTALLATION NOTES

- 1) PLACE FILL IN TWO LIFTS TO REDUCE HYDROSTATIC PRESSURE ON THE ADJACENT WALLS. THE FIRST LIFT SHALL BE APPROXIMATELY 8" HIGH. THE SECOND LIFT SHALL BE INSTALLED ONLY AFTER THE FIRST LIFT HAS SET.
- 2) MECHANICALLY VIBRATE FILL AS REQUIRED TO ENSURE PLACEMENT TIGHT TO UNDERSIDE OF RAMP DECK. PRESSURIZATION OF THE FLOWABLE FILL TO AID COMPLETE FILLING OF THE PIPE CHASE SHALL NOT EXCEED THE EQUIVALENT OF 2 FEET OF FILL ABOVE THE TOP OF THE SLAB.
- 3) THE SPACING AND LOCATION OF HOLES USED FOR FILL PLACEMENT ARE THE RESPONSIBILITY OF THE CONTRACTOR. THE SMALL HOLES DESIGNATED IN THE DETAIL FOR VERIFICATION OF FILLING ARE REQUIRED TO BE INSTALLED PER THE DETAIL 2. THE CONTRACTOR SHALL CONTACT THE ENGINEER PRIOR TO THE INSTALLATION OF THE SECOND LIFT SO THAT THE INSTALLATION CAN BE OBSERVED. IF THE METHOD OF INSTALLATION CHOSEN BY THE CONTRACTOR DOES NOT CREATE A TIGHT PLACEMENT OF THE FLOWABLE FILL TO THE UNDERSIDE OF THE SLAB, THE ENGINEER SHALL CALL FOR THE FILL INSTALLATION TO BE STOPPED AT THE CONTRACTOR'S EXPENSE UNTIL THE METHOD OF INSTALLATION IS AMENDED TO ENSURE A PLACEMENT OF THE FLOWABLE FILL TIGHT TO THE UNDERSIDE OF THE SLAB.
- 4) IT IS THE RESPONSIBILITY OF THE CONTRACTOR TO INSTALL THE FLOWABLE FILL IN A MANNER THAT PREVENTS DAMAGE TO THE EXISTING STRUCTURE. ANY DAMAGE TO THE EXISTING STRUCTURE SHALL BE REPAIRED AT THE CONTRACTOR'S EXPENSE.

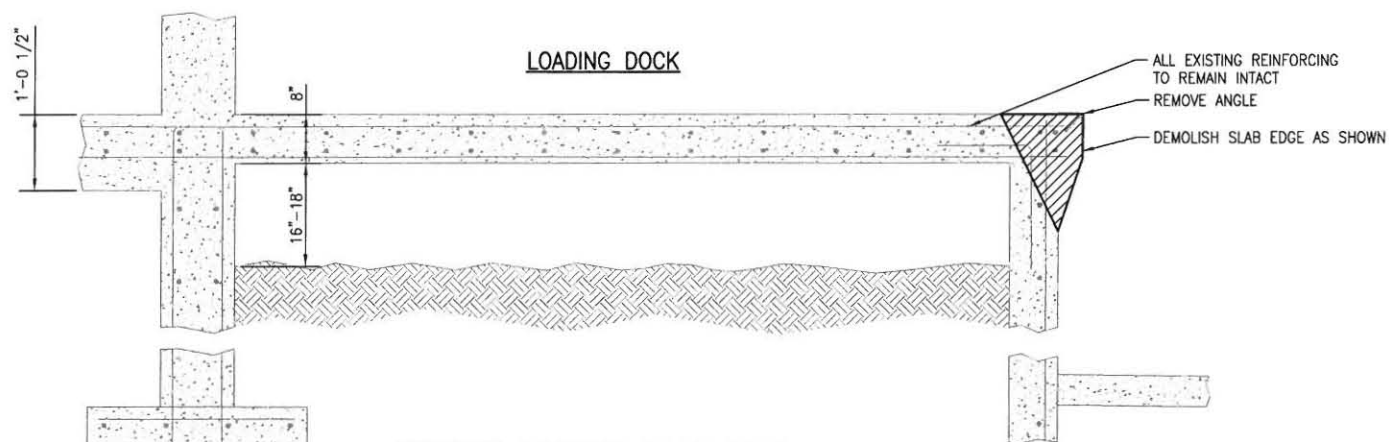

EXISTING LOADING DOCK RAMP DEMOLITION SECTION
SCALE: 3/8"=1'-0"

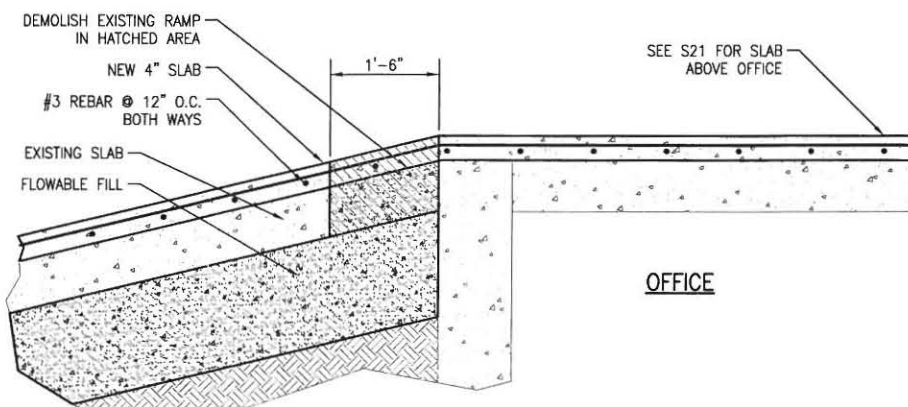

RAMP REPLACEMENT DETAIL
SCALE: 3/8"=1'-0"

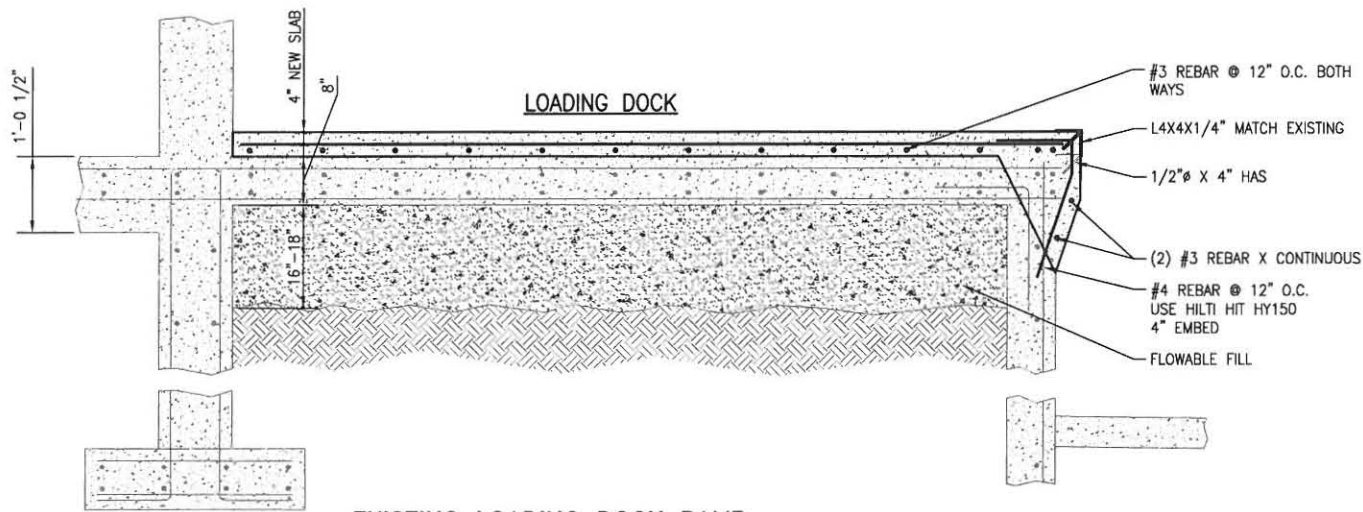
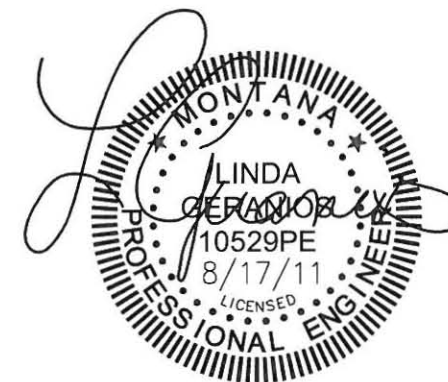

EXISTING LOADING DOCK RAMP REPLACEMENT SECTION
SCALE: 3/8"=1'-0"

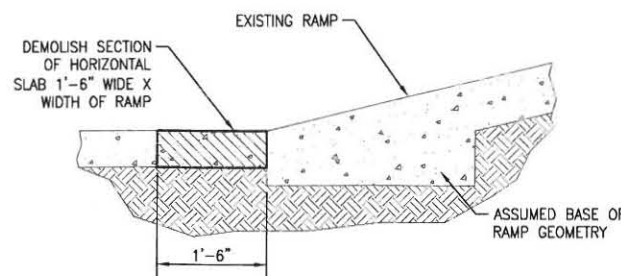

RAMP BASE DEMOLITION SECTION
SCALE: 3/8"=1'-0"

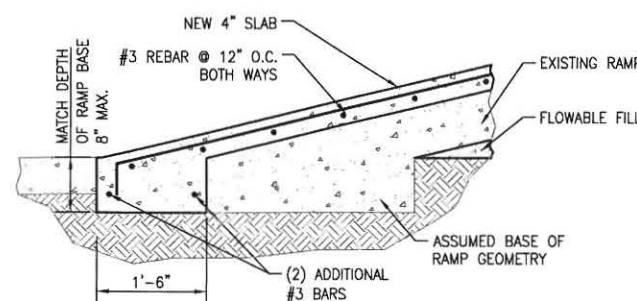

RAMP BASE SECTION
SCALE: 3/8"=1'-0"

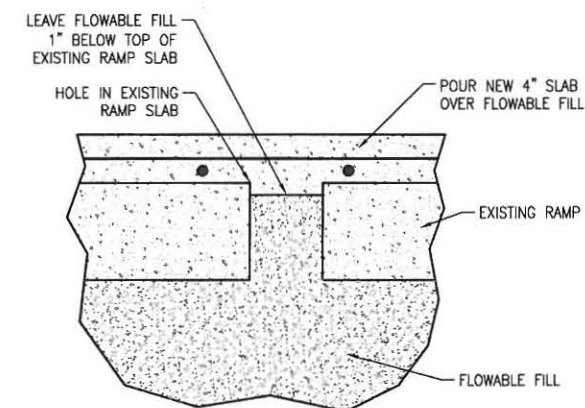

FILL HOLE DETAIL
SCALE: 3/4"=1'-0"

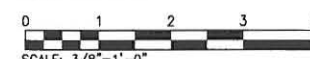
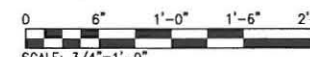
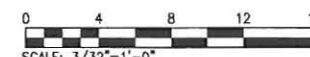

CONTRACTOR VERIFY ALL MEASUREMENTS

CITY OF GREAT FALLS POLICE DEPARTMENT
112 1ST STREET SOUTH
GREAT FALLS, MT

POLICE DEPARTMENT REHABILITATION
REVISED DOCK PLAN

DATE ISSUED	
ISSUE NO.	
ISSUED FOR	
THIS DRAWING IS THE PROPERTY OF THE ENGINEER. IT HAS BEEN PREPARED SPECIFICALLY FOR THIS PROJECT AND IS NOT TO BE REPRODUCED OR USED FOR ANY OTHER PURPOSE WITHOUT THE WRITTEN CONSENT OF THE ENGINEER.	
© LACY & EBELING ENGINEERING, INC.	

PLOT SCALE: NOTED	
DATE: 8/17/11	JOB NUMBER: 10-056
DRAWN BY: MK	DESIGNED BY: LG
CAD FILE: 1056-ADD1	

LACY & EBELING ENGINEERING INC.
FAX: (406) 761-4026
TEL: (406) 761-1088
EMAIL: LE-ENG@E-ENG.COM
GREAT FALLS, MONTANA

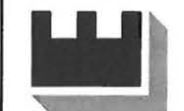



Agenda # 14
Commission Meeting Date:
September 20, 2011

**CITY OF GREAT FALLS
COMMISSION AGENDA REPORT**

Item: Final Payment – 2010 CDBG Sidewalk Replacement, O. F. 1588.2
From: Engineering Division
Initiated By: Public Works Department
Presented By: Jim Rearden, Public Works Director
Action Requested: Approve Final Pay Request

Suggested Motion:

1. Commissioner moves:

“I move the City Commission approve the Final Payment for 2010 CDBG Sidewalk Replacement, O. F. 1588.2 in the amount of \$2,616.68 to Gregoire Construction, and \$26.43 to the State Miscellaneous Tax Fund and authorize the City Manager to make the payments.”

2. Mayor calls for a second, discussion, inquiries from the public, and calls for the vote.

Staff Recommendation: Approve final payment request.

Background:

Original Bid Opening Date: Six bids were received and opened for this project on August 25, 2010.

Bid Amount: Gregoire Construction submitted the low bid of \$46,000.00.

Commission Award Date: The City Commission awarded the contract to Gregoire Construction on September 7, 2010. Change Order No. 1 was approved in the amount of \$7,024.65 by the City Commission August 2, 2011, and was paid for using additional CDBG funds that became available after the project was awarded.

Final Payment: The final project cost is \$52,862.20 which is \$162.45 less than the amount that was awarded and approved.

Project Work Scope: This project replaced sidewalks that had been damaged by tree roots, natural deterioration, or other destructive forces that had left the sidewalk dangerous for pedestrians. The grant paid for all of the costs of the sidewalk replacement for low to

moderate income homeowners. The original contract replaced sidewalks at 18 residences which included over 6,870 square feet of new 4 and 6-inch sidewalk and 2,640 square feet of sodding. Change Order No. 1 replaced sidewalks at 5 residences which included over 1,030 square feet of new 4 and 6-inch sidewalk and 510 square feet of sodding. Sidewalks were replaced at various locations throughout the City with the majority being bounded by the area of 3rd Avenue South to 9th Avenue South from 2nd Street to 9th Street.

Conclusion: City staff has verified that Gregoire Construction has completed all work and punch list items in accordance with the plans and contract. The City can accept the project and execute the Final Payment. The project was completed within the contract time. The two year warranty period started at the time of substantial completion which was July 8, 2011.

Fiscal Impact:

This project was funded entirely through CDBG grant funds.

Alternatives:

The City Commission could vote to deny Final Pay

Attachments/Exhibits:

1. Application for Final Payment is attached. (Not available online; on file in City Clerk's Office.)



Item: Final Payment for 25th Avenue NE Improvements - O. F. 1615
From: Engineering Division
Initiated By: Public Works Department
Presented By: Jim Rearden, Public Works Director
Action Requested: Approve Final Pay Request

Suggested Motion:

1. Commissioner moves:

"I move that the City Commission approve Final Payment in the amount of \$64,854.30 for the 25th Avenue NE Improvements - O. F. 1615 to United Materials of Great Falls, Inc. and the State Miscellaneous Tax Division and authorize the City Manager to execute the necessary documents and make the payments."

2. Mayor calls for a second, discussion, inquiries from the public, and calls for the vote.

Staff Recommendation:

Approve Final Pay Request

Background:

Original Bid Opening Date: Two bids were received on July 8, 2011 with the bids ranging between \$71,021.00 and \$84,375.00.

Bid Amount: United Materials of Great Falls, Inc. submitted the low bid of \$71,021.00.

Commission Award Date: The City Commission awarded the contract to United Materials on July 19, 2011.

Final Payment: The final project cost is \$64,854.30, which is \$6,166.70 less than the amount that was awarded and approved.

Project Work Scope: The project constructed approximately 1,000 lineal feet of new curb and gutter, widened the roadway by five feet, installed a storm drain valley gutter and

approach to 10th Street NE, made improvements to the storm drain system, re-graded the south boulevard area, and completed miscellaneous other restoration and streetscape work. The project was completed within the allotted contract time.

Conclusion: City staff has verified that United Materials has completed all work in accordance with the plans and contract documents. The project was completed within the contract time. The two-year project warranty started at the time of substantial completion, which was August 18, 2011.

Fiscal Impact:

This project is being funded by street and storm drain funds. The Animal Foundation will be billed in the amount of \$8,547.95 for the cost of the curb and gutter, roadway, and boulevard improvements that were constructed adjacent to their property. The reimbursement will be credited to street and storm drain funds.

The City will seek reimbursement for the cost of the improvements constructed next to two other adjacent properties at the time of annexation.

Alternatives:

The City Commission could vote to deny the Final Payment

Attachments/Exhibits:

1. Application for Final Payment is attached. (Not available online; on file in City Clerk's Office.)